

# Guided Wave Radar Level Transmitter (TDR)



measuring  
•  
monitoring  
•  
analyzing

NGM

ATEX 



- For Liquids or Solids
- Independent of Density, Temperature, Pressure, Humidity, or Conductivity
- Measuring Length: Max. 65.5 feet
- Temperature Range: -230...480 °F
- Pressure Range: -14.5...580 PSIG
- Output: 4 ... 20 mA & PNP Switching Output



KOBOLD companies worldwide:

AUSTRALIA, AUSTRIA, BELGIUM, BULGARIA, CANADA, CHINA, CZECHIA, FRANCE, GERMANY, GREAT BRITAIN, HUNGARY, INDIA, INDONESIA, ITALY, MALAYSIA, MEXICO, NETHERLANDS, PERU, POLAND, REPUBLIC OF KOREA, RUSSIA, SPAIN, SWITZERLAND, THAILAND, TUNISIA, TURKEY, USA, VIETNAM

KOBOLD Instruments, Inc.  
1801 Parkway View Drive  
Pittsburgh, PA 15205  
Main Office:  
1.800.998.1020  
1.412.788.4890  
info@koboldusa.com  
www.koboldusa.com

**Description**

The NGM uses TDR (Time Domain Reflectometry) technology, which is also known as Guided Microwave or Guided Wave Radar. This means that low-energy and high-frequency electromagnetic impulses, generated by the sensor's circuitry, are propagated along the probe which is immersed in the liquid or solid to be measured. When these impulses hit the surface of the media, part of the impulse energy is reflected back up the probe to the circuitry which then calculates the level from the time difference between the impulses sent and the impulses reflected. The sensor can output the level as a 4...20 mA analog output, or it can convert the values into a freely programmable switching output signal.

**Sensor Components**

The NGM consists of three major components: housing, feed-through, and probe. The only components that are exposed to the atmosphere inside the tank are the probe and the part of the feed-through below the lock nut. The housing contains the sensor's electronics and input/output terminals and has no contact with the tank atmosphere. The feed-through is mounted into the bottom of the housing and serves two main purposes: its outer threaded metal bushing securely connects the sensor to the tank and its inner components guide the high frequency measurement signal from the electronics through the tank wall into the tank and back. The probe is immersed in the media and propagates the signal. The NGM has a flexible modular concept. Any probe can be used with any housing since they are joined together by one universal feed-through.

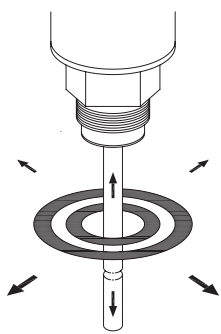

Single Rod/Rope Probe

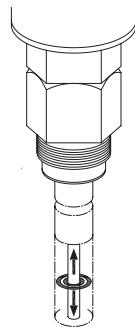

Concentric Probe

**Application Area**

The innovative TDR technology enables direct, precise, and highly reliable continuous level measurement as well as point level detection in almost every liquid or light solid application independent of changing process conditions (such as density, conductivity, temperature, pressure or air humidity). The NGM can be mounted in small tanks, tall and narrow nozzles, and it measures precisely even with difficult tank geometries or in proximity to interfering structures. The NGM is also suitable for bypass chambers and stilling wells. It has exceptional performance in media with a low dielectric constant (i.e. low reflectivity) such as oils and hydrocarbons.

**Highlights**

- Level measurement independent of pressure, temperature, humidity, or conductivity
- Suitable for almost all media, liquids, and light solids
- Fully modular probe design, i.e. the probe types are interchangeable without any special tools or welding
- Complete galvanic insulation of electronics from the inputs/outputs and the tank potential to protect against electrochemical corrosion protection
- Dependable measurement due to 4-wire design and innovative signal analysis and disturbance signal suppression

**Sensor Components**

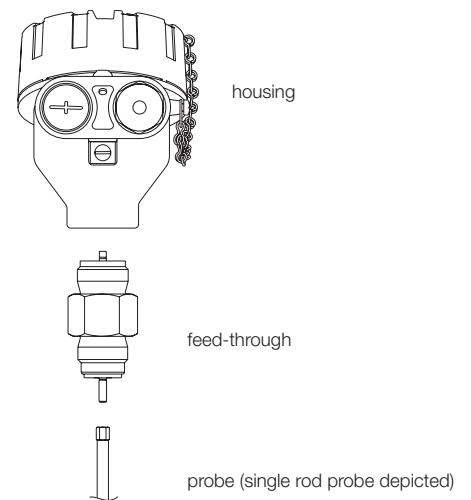

**Modular Probe Design**

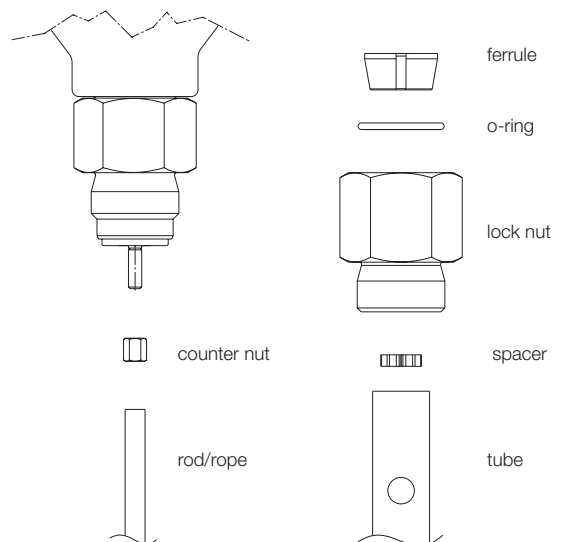

No responsibility taken for errors; subject to change without prior notice.



**Probe Types**

**Single Rod (max. 9.8 ft)**

The single rod probe has a wider detection radius around the rod. They are more responsive to measurement signal disturbances which can be easily overcome by observing a few mounting considerations and making simple configuration adjustments to the sensor. The single rod probe is recommended for liquid applications in bypass chambers and stilling wells.

**Wire Rope (max. 65.6 ft)**

The wire rope probe is recommended for installation in light solids and liquids in tall tanks where limited headroom is available. It is suitable for a wide range of applications, but the signal has a wider detection radius around the rope, just like single rod probe, and is more responsive to measurement signal disturbances.

**Concentric (max. 19.5 ft)**

In the concentric probe, the high-frequency measurement signal is completely contained within the outer tube. As a result, the concentric probe is immune to any external conditions and interfering objects outside its tube which would otherwise cause disturbances. This advantage makes the concentric probe the ideal hassle-free solution, ensuring reliable measurement under almost any conditions. The concentrated signal within the tube also makes the concentric probe the ideal choice for measuring low reflectivity liquids (i.e. low dielectric constants) such as oils and hydrocarbons. It is recommended for use with clean liquids only and cannot be used with solids; viscous, crystallizing, adhesive, coating, fibrous, or sticky liquids; sludge, slurry, pulp; or any liquids containing solid particles.

**Application Guide**

Mounting Type/Probe Type	Rod Probe	Wire Rope	Concentric
Tall and Narrow Nozzles	*	*	+
Difficult Tank or Nozzle Geometries	*	*	+
Close to Internal Tank Structures or Tank Wall	*	*	+
Probe Might Move or Touch Internal Tank Structures or Tank Wall	*	*	+
Liquid Spray May Touch Probe above the Liquid Surface	*	*	+
Non-stationary Interference Targets, e.g. Agitator Blades	*	*	+
Measurement Readings at the Very Top or Bottom of the Tank	*	*	+
Non-metallic Tanks	*	*	+
Bypass Chambers and Stilling Wells	*	-	*
Limited Headroom for Installation	*	+	*
Tall Tanks	*	+	*
<b>Media Characteristics</b>			
Bulk Solids	-	+	-
Liquids with Low Dielectric Constants	*	*	+
Viscous, Crystallizing, Adhesive, Coating or Sticky Liquids	+	+	-
Fibrous Liquids, Sludge, Slurry, or Pulp	+	+	-
Liquids Containing Solid Particles	+	+	-
Ability to Clean the Probe is Important	+	+	-

+ = recommended    - = not recommended    \* = may be possible with configuration and/or mounting adjustments



**Technical Data (Wetted Parts)**

	Single Rod	Wire Rope	Concentric
Probe Diameter	6 mm	4 mm	17.2 mm
Max. Load	Lateral: 6 Nm = 0.2 kg at 3 m	Tensile: 5 kN	Lateral: 100 Nm = 1.67 kg at 6 m
Probe Length	4" ... 118"	40" ... 787"	4" ... 236" (standard) 4" ... 40" (high temperature)
Dielectric Constant ( $\epsilon_r$ )	> 1.8	> 1.8	> 1.4
Viscosity (cP)	< 5000	< 5000	< 500
Media Temperature, Standard Version	-40...302 °F (without PTFE) 5...212 °F (PTFE lining)	-40...302 °F	-40...266 °F (EPDM O-ring) 5...302 °F (FKM O-ring)
High Temperature Version	-328...482 °F (NBR O-ring) -238...482 °F (FKM O-ring)	Not available	-328...482 °F (NBR O-ring) -238...482 °F (FKM O-ring)
Materials Exposed to Tank Atmosphere	Standard: 316-Ti Stainless Steel, PEEK PTFE, O-ring (see order code), (PTFE lining) High Temp: 316-Ti Stainless Steel, PEEK, PTFE, O-ring (see order code) In all cases, in addition, a Klinger SIL <sup>®</sup> C-4400 gasket at connection thread, 2 mm thick	316 Stainless Steel, PEEK In addition, a Klinger SIL <sup>®</sup> C-4400 gasket at connection thread, 2 mm thick	Standard: 316 L Stainless Steel, PEEK, O-ring (see order code), High Temp: 316 L Stainless Steel, PEEK, PTFE, O-ring (see order code) In all cases, in addition, a Klinger SIL <sup>®</sup> C-4400 gasket at connection thread, 2 mm thick

**Measuring Principle:** Guided Wave Radar (GWR)  
**Installation Position:** Vertical  
**Ambient Temperature:** -10 ... 176 °F (Electronics and Housing)  
**Storage Temperature:** -40 ... 185 °F  
**Max. Pressure:** -14.5 ... 580 PSIG  
 (except NGM-19: 0 ... 58 PSIG)  
**Accuracy\*:** ±3 mm or 0.03 % of measured distance, whichever is greater  
**Repeatability\*:** < 2 mm  
**Resolution\*:** < 1 mm

\*Reference condition:  $\epsilon_r=80$ , water, tank  $\phi$ 1 m, DN200 metal flange

**Velocity of Level Change:** < 1000 mm/s  
**Media Conductivity:** No restrictions  
**Media Density:** No restrictions  
**Process Connection:** Thread or flange, see ordering code

**Special Application Consideration:** An oil layer < 2.8" on top of water is not detected by the sensor and the sensor will read the level at a slightly lower position than actual. For an oil layer > 2.8", the sensor will detect the total level, including the oil layer.

**Materials**  
**Housing:** Aluminum alloy, epoxy coated, with safety chain and tin plated 304 SS external grounding screw  
 Option: 316 Stainless steel  
**O-ring:** NGM Rod/Rope: None  
 NGM Concentric: FKM or EPDM  
 NGM High Temperature: NBR or FKM

**Weights**  
**Housing inc. Electronics:** 1.6 lb  
**Stainless Steel Housing inc. Electronics:** 3.0 lb  
**Process Connection 3/4": (Rod/Rope):** 0.5 lb  
**Process Connection 3/4": (Concentric)** 0.8 lb  
**1m Rod Probe:** 0.5 lb  
**1m Rope Probe:** 0.15 lb + 0.85 lb ballast weight  
**1m Concentric Probe:** 1.2 lb + 0.3 lb (attachment kit)  
**Cooling Extension for High Temperature:** 2.0 lb

**Electrical Data**

**Supply Voltage:** 12 ... 30 V<sub>DC</sub> (reverse-polarity protected <50 mA), 4-wire system

**Output:** 4 ... 20 mA

**Total Load:** < 500 Ω  
approx. 250 Ω + load resistance  
approx. 250 Ω

**Response Time:** 0.5s (default), 2s, 5s (selectable)

**Temperature Drift:** <0.2 mm/K change in ambient temperature

**Switching Output**

**DC PNP (Active):** NC (default) or NO (short-circuit protected)

**Load Current:** < 200 mA

**Signal Voltage HIGH:** Supply voltage - 2 V

**Signal Voltage LOW:** 0 V...1 V

**Response Time:** < 100 ms

**Current Consumption:** < 50 mA at 24 V<sub>DC</sub> (no burden)

**Start-up Time:** < 6 s

**Cable Terminals:** Clamp terminal block for cable  
0.5...2 mm<sup>2</sup>

**Cable Entry:** 2 x M20 x 1.5

**Protection:** IP68

**ATEX Certification**

CE 0158 SEV 13 ATEX 0108 X

II 1/2G Ex ia/db IIC T6 Ga/Gb

II 1/2D Ex ia/tb IIIC T86°C IP68 Da/Db

II 2G Ex ia db IIC T6 Gb

II 2D Ex ia tb IIIC T86°C IP68 Db

**Measuring Range**

The probe length [L] is not equal to the actual measuring range [M] of the sensor. TDR level sensors have small inactive areas at top [L1] and bottom [L2] of the probe, due to unavoidable signal disturbances at both ends of the probe. In these inactive areas the measurements are nonlinear or have reduced accuracy. It is not recommended to measure level within those inactive areas. The inactive areas depend on the probe type and the reflectivity (i.e. dielectric constant) of the liquid/solid to be measured (see table). The measuring range [M] should be between the top and bottom inactive areas of the probe. The location of the switching point [S] can be freely positioned within the measuring range [M]. Fixed hysteresis or separate upper and lower thresholds can be defined for the switching output.

**Mounting Considerations**

No responsibility taken for errors; subject to change without prior notice.

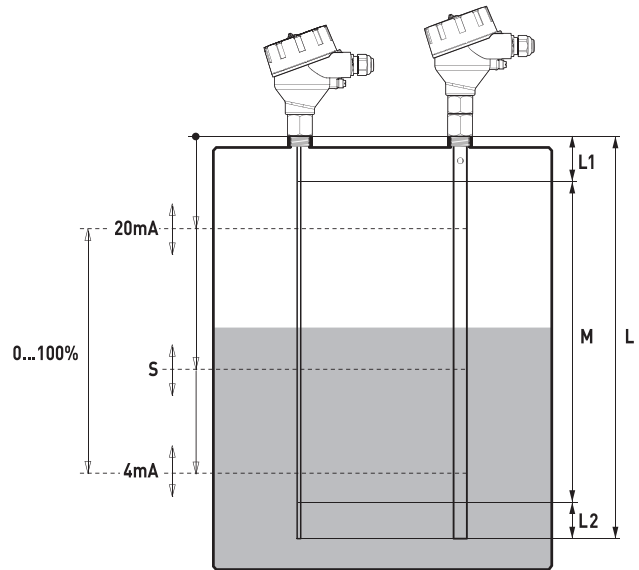

ε <sub>r</sub> = 80			
in mm	Rod Probe	Wire Rope	Concentric
L1 (top)	50	50	30
L2 (bottom)	10	10	10
ε <sub>r</sub> = 2			
L1 (top)	80	80	50
L2 (bottom)	50	50	50

Factory adjustment: L1 = 50 mm, L2 = 10 mm; S = 0.2 L from top, hysteresis = 3 mm, NC

Mounting Type/ Probe Type	Rod Probe	Wire Rope	Concentric
Nozzle diameter	> 50 mm	> 50 mm	ø >17.2 mm
Nozzle height	< 300 mm	< 300 mm	no restrictions
Clearance to tank or other internal objects	> 100 mm	> 100 mm	no restrictions
Clearance between probe end and tank bottom	> 2 mm	> 2 mm	no restrictions
Diameter of bypass chamber/ stilling well (only for liquids)	> 25 mm	> 25 mm	ø >17.2 mm*

\*There should be enough room around the probe for the liquid to flow in and out of the bypass chamber/stilling well.



## Guided Wave Radar Level Transmitter Model NGM

### Electrical Connection

The NGM is a 4-wire system with a set of 2 wires for the power supply and a separate set of 2 wires for each output. The electronic is galvanically isolated from the inputs/outputs and the tank potential, thus avoiding problems with electrochemical corrosion protection of the tank. As standard, each unit is supplied factory set with your specific operating parameters upon ordering, making the physical installation essentially a "plug and play" operation. If necessary, basic "in-field" configuration of the device may be easily accomplished via an internal DIP switch, single push button, and visual feedback from an LED.

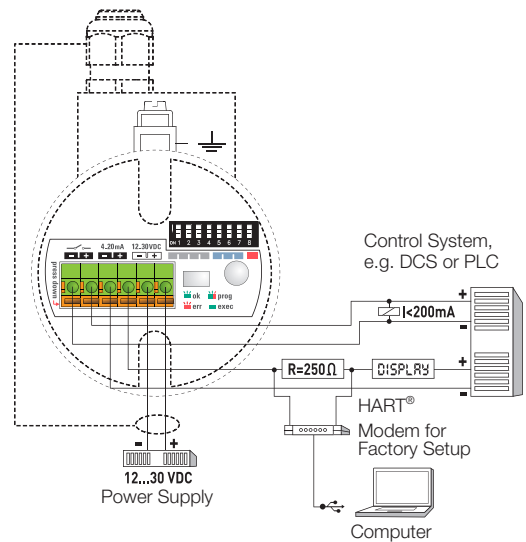

### Order Details HART® modern: HARTCOMM



Model	Material (Probe/O-ring)	Connection	Output	Option
NGM-1..	Rod Probe ..200.. = Stainless Steel, PEEK/ without O-ring ..900 <sup>5)</sup> .. = Stainless Steel, PEEK/FKM PTFE Coating	..N5.. = ¼" NPT Male ..G5.. = G ¾ Male ..A8.. = 1½" ASME B16.5 CL150 ..A9.. = 2" ASME B16.5 CL150	..A4.. = 4 ... 20 mA, PNP  ..E4 <sup>4)</sup> .. = 4 ... 20 mA, PNP, ATEX-version	00 = without E0 = stainless steel housing B3 <sup>1)</sup> = mounted in Bypass with DIN-Flange DN10/PN40 B4 <sup>1)</sup> = mounted in Bypass with DIN-Flange DN15/PN40 B5 <sup>1)</sup> = mounted in Bypass with DIN-Flange DN20/PN40 B6 <sup>1)</sup> = mounted in Bypass with DIN-Flange DN25/PN40 BB <sup>1)</sup> = mounted in Bypass with ANSI-Flange ½" 300 lbs BC <sup>1)</sup> = mounted in Bypass with ANSI-Flange ¾" 300 lbs BD <sup>1)</sup> = mounted in Bypass with ANSI-Flange 1" 300 lbs S1 <sup>2)</sup> = mount. in stilling well DIN-Flange DN40/PN40 S2 <sup>2)</sup> = mount. in stilling well DIN-Flange DN50/PN40 S3 <sup>2)</sup> = mount. in stilling well DIN-Flange DN80/PN40 S4 <sup>2)</sup> = mount. in stilling well DIN-Flange DN100/PN16 SA <sup>2)</sup> = mount. in stilling well 1½" ASME B16.5 CL150 SB <sup>2)</sup> = mount. in stilling well 2" ASME B16.5 CL150 SC <sup>2)</sup> = mount. in stilling well 2½" ASME B16.5 CL150 SD <sup>2)</sup> = mount. in stilling well 3" ASME B16.5 CL150 SE <sup>2)</sup> = mount. in stilling well 4" ASME B16.5 CL150 K0 <sup>3)</sup> = mounted in Bypass with roller/ball display  YY =special
NGM-8..	Rod Probe, High Temperature ..210.. = Stainless Steel, PEEK/NBR ..220.. = Stainless Steel, PEEK/FKM	..AB.. = 3" ASME B16.5 CL150 ..AC.. = 4" ASME B16.5 CL150 ..F8.. = DN40/ PN40 B1, 316L Flange EN1092-1		
NGM-2..	Concentric Probe ..230.. = Stainless Steel, PEEK/EPDM ..220.. = Stainless Steel, PEEK/FKM	..F9.. = DN50/ PN40 B1, 316L Flange EN1092-1 ..FB.. = DN80/ PN0 B1, 316L Flange EN1092-1		
NGM-9..	Concentric Probe, High Temperature ..210.. = Stainless Steel, PEEK/NBR ..220.. = Stainless Steel, PEEK/FKM	..FC.. = DN100/ PN16 B1,316L Flange EN1092-1 1		
NGM-4..	Wire Rope Ø 4 mm (liquids and light solids only) ..200.. = Stainless Steel, PEEK/ without O-ring	..XX.. = Special Design (please specify in writing)		

<sup>1)</sup> Bypass specification, see NBK-M data sheet

<sup>2)</sup> please specify probe length L and stilling well length (in inches) in clear text while ordering

<sup>3)</sup> Bypass specification, see NBK data sheet. Maximum measuring length is 18 feet. Not possible with NGM-2, -4, -9. Max. media viscosity of 500 cP.

<sup>4)</sup> not possible with NGM-19..., NGM-8... and NGM-9...

<sup>5)</sup> not possible for flange sizes < DN50/PN40 and < 2½" ASME 150 lbs, not possible for G and NPT thread

**Note:** When ordering, please specify probe length "L" for option 'S'. For options 'B' or 'K', the "ML", center to center length, of the NBK device should be specified (please see NBK datasheet for more details).

**Dimensions (mm)**

**NGM-12../NGM-4.. with Thread Connection**

Single Rod /Wire Rope Probe  
Standard Application Temperature

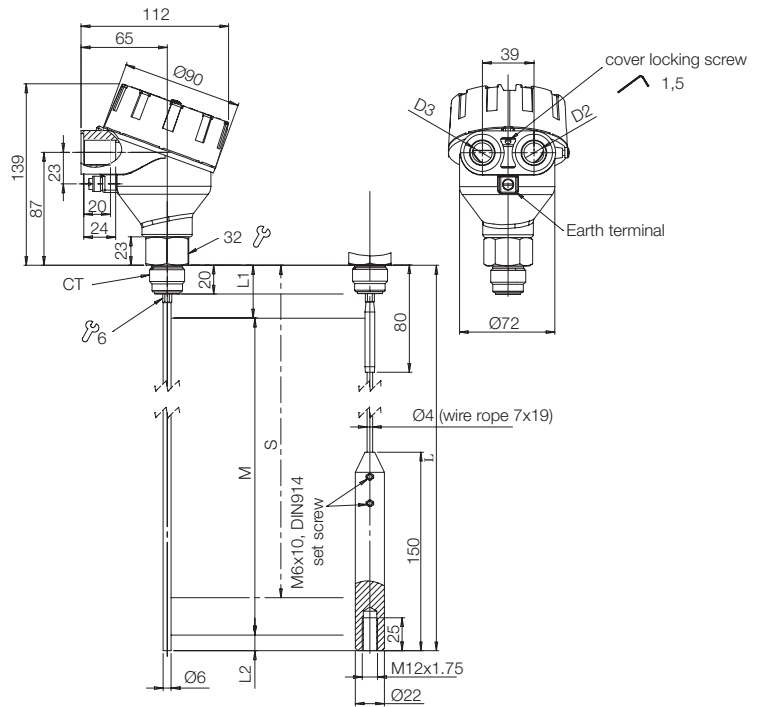

**NGM-12../NGM-4.. with Flange Connection**

Single Rod Version

Wire Rope Version

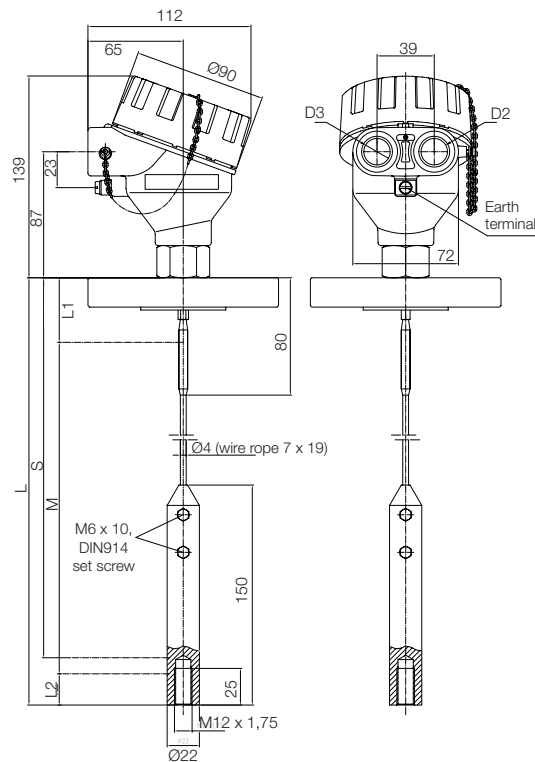
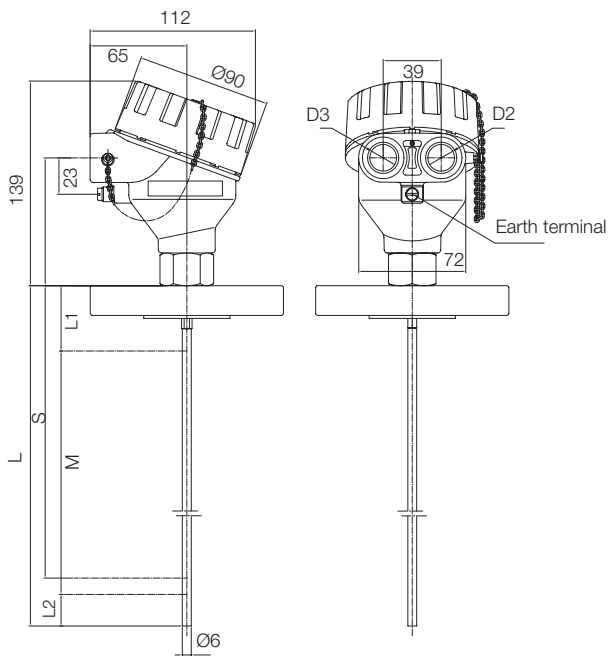

**NGM-2.. with Threaded Connection**

Concentric Probe  
Standard Application Temperature

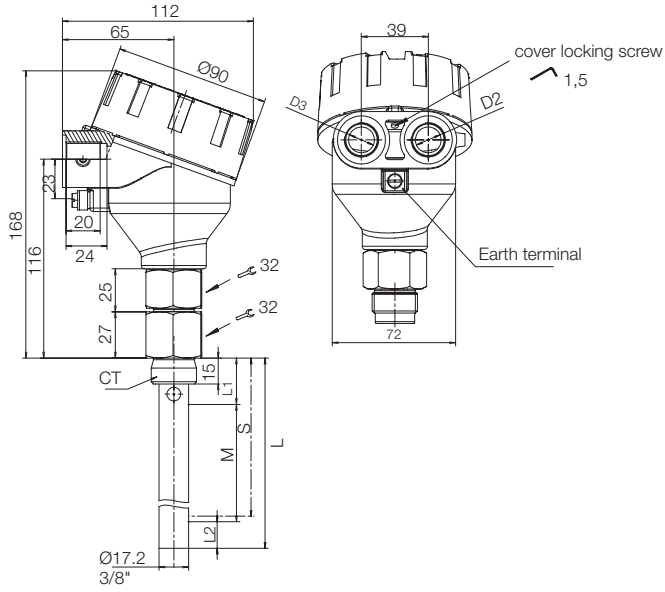

**NGM-2.. with Flanged Connection**

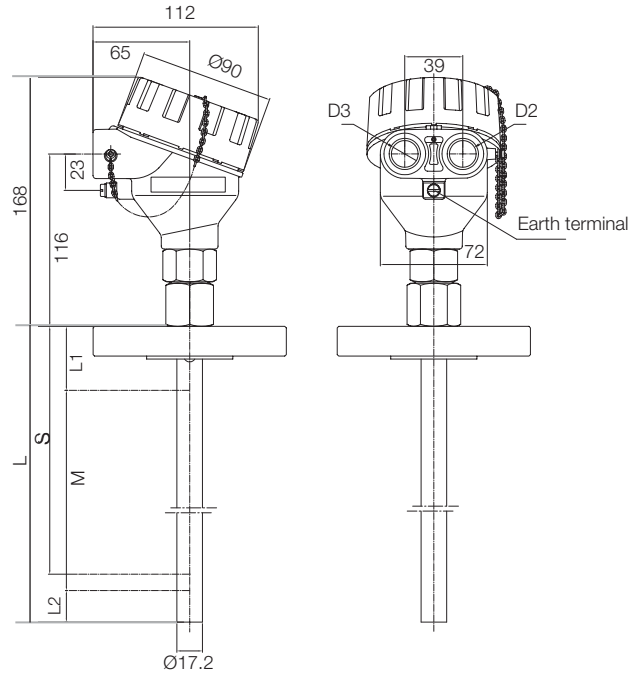

**NGM-19.. with Flanged Connection**

Single Rod Probe, PTFE Coated  
Flange Disk

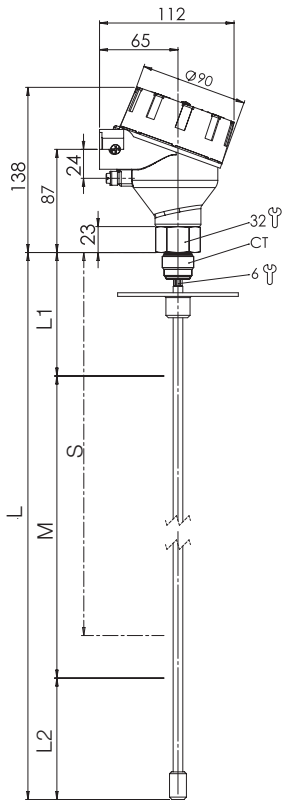

**NGM-19.. with Threaded Connection**

Single Rod Probe, PTFE Coated  
Threaded Connection

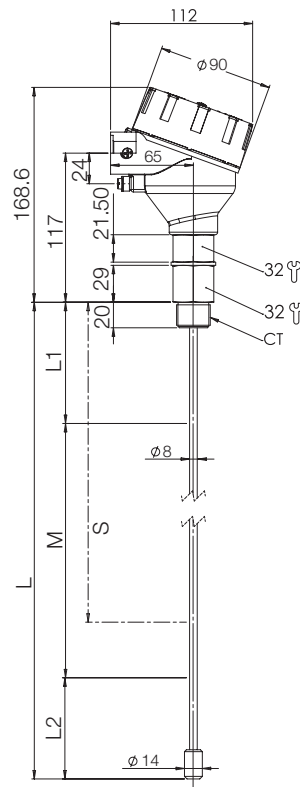



NGM with Option "..S" (Mounted on Stilling Well)

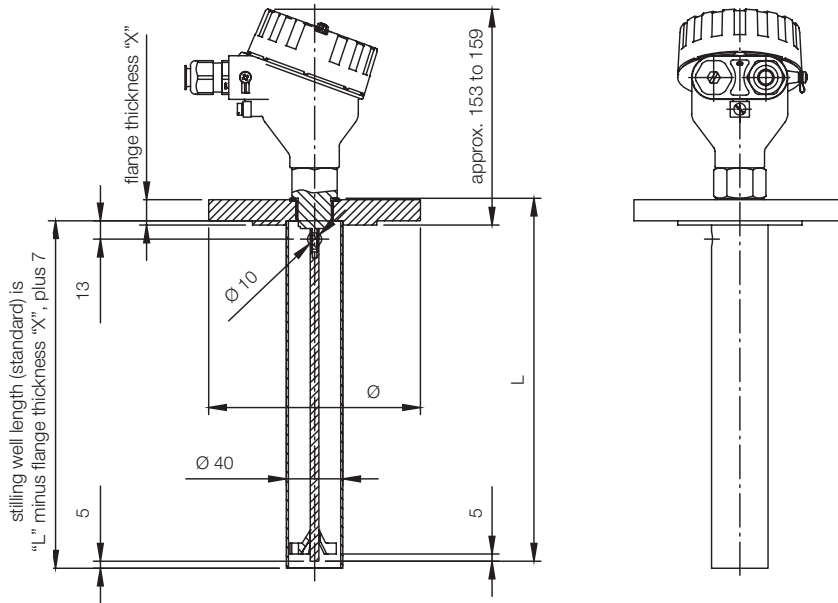

Connection	Flange	"X"	Ø
A8	1½"/CL150	17.9	125
A9	2"/CL150	19.5	150
AA	2½"/CL150	22.7	180
AB	3"/CL150	24.3	190
AC	4"/CL150	24.3	215
F8	DN40/PN40	18	150
F9	DN50/PN40	20	165
FB	DN80/PN40	24	200
FC	DN100/PN16	20	220

NGM with Option "..K" (Assembled in Bypass Tube with Roller/Ball display (Redundant Measurement))

