

# Magnetic Inductive Flowmeter

## All-Metal Design



measuring  
•  
monitoring  
•  
analyzing

MIM



### IO-Link

- For Measurement and Monitoring of Conductive Liquids
- Flow and Temperature Measurement
- Switching, Transmitting, and Batching Functions
- Bi-directional Flow Measurement
- Rugged Stainless Steel Construction
- $p_{\max}$ : 230 PSI;  $t_{\max}$ : 284 °F
- Accuracy:  $< \pm (0.8\% \text{ of Reading} + 0.5\% \text{ of Full Scale})$



KOBOLD companies worldwide:

AUSTRALIA, AUSTRIA, BELGIUM, BULGARIA, CANADA, CHINA, CZECHIA, FRANCE, GERMANY, GREAT BRITAIN, HUNGARY, INDIA, INDONESIA, ITALY, MALAYSIA, MEXICO, NETHERLANDS, PERU, POLAND, REPUBLIC OF KOREA, RUSSIA, SPAIN, SWITZERLAND, THAILAND, TUNISIA, TURKEY, USA, VIETNAM

KOBOLD Instruments, Inc.  
1801 Parkway View Drive  
Pittsburgh, PA 15205  
Main Office:  
1.800.998.1020  
1.412.788.4890  
info@koboldusa.com  
www.koboldusa.com



## Magnetic Inductive Flowmeter, All-Metal Design Model MIM

### Description

The new MIM electromagnetic flowmeter measures and monitors small to medium sized flow of conductive liquids in pipes. According to Faraday's Law of magnetic induction, a voltage is induced in a conductor moving through a magnetic field. The electrically conductive measured media acts as the conductor. The voltage induced in the measured media is proportional to the flow velocity and is therefore a value for the volumetric flow. The induced voltage is detected by two sensing electrodes which are in contact with the measuring media and sent to an integrated amplifier. The flow rate will be calculated based on the cross sectional area of the pipe. The measurement does not depend on the process liquid and its properties such as density, viscosity and temperature. The two outputs can be independently set to switch, or provide an analog or frequency output. A batching function can also be selected, where output 1 is set to switch as NPN/PNP/PP and output 2 is set as the control input.

### Features

- Rugged Stainless Steel Construction
- Flow and Temperature Measurement
- Switching, Transmitting, and Batching Functions
- Batching Function with External Control Input
- Bi-directional Flow Measurement
- Colored, Multi-parameter, Configurable TFT Display, Rotatable in 90° Increments
- Intuitive Setup Menu via 4 Optical Touch Keys
- 2 Configurable Outputs (Pulse/Frequency/Alarm/Analog Output)
- Grand and Resettable Totalizer
- Drinking Water Approval

### Technical Details

**Measurement Principle:** Electromagnetic

**Ranges:** 0.16...16 GPH to 0.8...170 GPM

**Media:** Conductive Liquids

**Min. Conductivity:**  $\geq 20 \mu\text{S/cm}$  ( $\geq 35 \mu\text{S/cm}$  for Measuring Ranges 01G/01H)

**Native Fittings:** G 1/4...G 2, or 1/2" NPT...2" NPT

**Optional Fitting Kits:** 1/4"...1" NPT (Male or Female), 1" or 2" Tri-Clamp® (All Kits Include 2x Fittings and 2x Klinger SIL Gaskets except Kit ZUB-AD2G50T50 that Includes 2x Fittings and 2x FKM O-rings)

**Max. Pressure:** 230 PSI

**Accuracy<sup>1)</sup>:**  $< \pm (0.8\% \text{ of Reading} + 0.5\% \text{ of Full Scale})$

**Repeatability:**  $\pm 0.2\% \text{ of Full Scale}$

**Response Time Flow  $t_{90}$**

**Alarm/Pulse/Frequency Output:**  $< 100 \text{ ms}$

**Analog Output:**  $< 1 \text{ s}$

**Temperature Measurement**

**Sensor:** PT1000

**Accuracy:**  $< \pm 3.6 \text{ }^\circ\text{F}$  (Flow  $> 0.2 \text{ m/s}$ )

**Measuring Range:** Temperature Range of the Media

**Response Time Temp.  $t_{90}$  (Signal Output):**  $< 20 \text{ s}$

<sup>1)</sup> Reference Cond.: Media: 60...85 °F, 1 cSt, 500  $\mu\text{S/cm}$ , 15 PSI, Ambient: 60...85°F

<sup>2)</sup> Limited functionality with black rubber gloves



**Programming<sup>2)</sup>:** Via 4 Optical Touch Fields, Can be used with Gloves

**Mounting Position:** Universal

**Inlet/Outlet:** 3x Upstream, 2x Downstream

**Pressure Drop:** See Pressure Loss Diagram

**Housing:** 316L Stainless Steel, PMMA Display Screen

### Wetted Parts

The wetted parts of MIM-13 (except measuring range code "35") are in conformance with DVGW 270 and WRAS guidelines for drinking water approval.

**Fitting/Housing:** 316L Stainless Steel

**Insulation Parts:** PEEK

**Electrodes:** 316L Stainless Steel

**Seals:** FKM or EPDM

**Fitting Adapter:** 316L Stainless Steel

### Temperature Ranges

Design	Electronics	Model	Seal	Media Temperature	Ambient Temperature
Compact Version	C3T	MIM-12	FKM	-4...158 °F <sup>1)</sup>	-4...140 °F
		MIM-13	EPDM		
Remote Version (PVC Cable)	P02	MIM-12	FKM	-4...185 °F	-4...140 °F (Display Electronics)
		MIM-13	EPDM		-4...185 °F (Sensor)
Remote Version (ETFE Cable)	E02	MIM-12	FKM	-4...284 °F	-4...140 °F (Display Electronics)
					-4...284 °F (Sensor)
		MIM-13	EPDM	-40...284 °F	-4...140 °F (Display Electronics)
					-40...284 °F (Sensor)

<sup>1)</sup> Continuous -4...158 °F, short-term up to max. 185 °F (for max. 60 minutes at max. 104 °F ambient temperature and repetition earliest after 4 hours). Use of the electrical output remains limited to temperature range -4...158 °F.

### Electrical Data

**Supply Voltage:** 19-30 V<sub>DC</sub>, Internal Power Consumption max. 200 mA

**Display:** TFT Display, 128x128 Pixels, 1.4" Display, Orientation Adjustable in 90° Increments

**Display Repetition Rate:** 0.5...10 s, Adjustable

**Pulse Output:** Push-Pull, Freely Scalable, Configurable for Partial and Accumulated Totalizer



**Technical Details** (continued)

**Electrical Data** (continued)

**Frequency Output:** Push-Pull, Fully Scalable, 2 kHz @ Overflow  
50...1000 Hz at Full Scale, User Programmable

**Alarm Output:** NPN, PNP, Push-Pull, Configurable Max. 30 V<sub>DC</sub>, Max. 200 mA Short-Circuit Proof

**Analog Output:** Active, 3-wire, 4-20 mA, Max. Load 500 Ω or 0-10 V<sub>DC</sub>, (R<sub>i</sub> = 500 Ω)  
(Factory Calibrated with R<sub>L</sub> = 1 M Ω)

**Control Input:** Active Signal U<sub>high</sub>, Max. 30 V<sub>DC</sub>, 0 < Low < 10 V<sub>DC</sub>, 15 V<sub>DC</sub> < High < V<sub>S</sub>

**Batching Function:** Batching Output OUT2: Push-Pull, High Active  
Control Input OUT1: START/STOP 0.5s < t<sub>high</sub> < 4s  
RESET t<sub>high</sub> > 5s

**Shock Resistance**

DIN EN 60068-2-27:2010: 20 g (11 ms)

**Vibration Resistance**

DIN EN 60068-2-6:2008: 5 g (10 ... 2000 Hz)

**Environmental Testing**

DIN EN 60068-2-30:2006: Severity Level b

**IO-Link Specification**

**Manufacturer ID:** 1105 (Decimal), 0 x 0451 (Hex)  
**Manufacturer Name:** Kobold Messring GmbH  
**IO-Link Specification:** V1.1  
**Bitrate:** COM3  
**Minimal Cycle Time:** 1.1 ms  
**SIO-Mode:** Yes (OUT1 in Configuration IO-Link)  
**Block Parameterisation:** Yes  
**Operational Readiness:** 10 s  
**Max. Cable Length:** 20 m  
**Protection:** IP67

**Order Details** (Example: MIM-12 05G N4 C3T 0)

Model	Measuring Range <sup>1)</sup>	Native Connection	Electronics	Options
MIM-12.. = SS Housing SS Electrodes FKM Seals	..01G.. = 0.16...16 GPH ..01H.. = 0.01...1 LPM	..G2.. = G 1/4 Male	..C3T.. = Compact TFT Display 2x Configurable Outputs (Current/Voltage/Pulse/ Frequency/Alarm) M12x1 Electrical Connection	0 = without K <sup>5)</sup> = Including Calibration Report
	..03G.. = 0.48...48 GPH ..05G.. = 0.01...2.6 GPM	..N4 <sup>3)</sup> .. = 1/2" NPT Female		
	..03H.. = 0.03...3 LPM ..05H.. = 0.04...10 LPM	..G4 <sup>3)</sup> .. = G 1/2 Male		
	..10G.. = 0.025...6.6 GPM ..15G.. = 0.05...13 GPM	..N5 <sup>3)</sup> .. = 3/4" NPT Female		
MIM-13 <sup>4)</sup> .. = SS Housing SS Electrodes EPDM Seals	..10H.. = 0.1...25 LPM ..15H.. = 0.2...50 LPM	..G5 <sup>3)</sup> .. = G 3/4 Male	..P02 <sup>2)</sup> .. = Remote Display Version, TFT Display, 2m PVC Cable, Max. 185 °F	
	..15G.. = 0.05...13 GPM ..20G.. = 0.1...26 GPM	..N6 <sup>3)</sup> .. = 1" NPT Female	..E02 <sup>2)</sup> .. = Remote Display Version, TFT Display, 2m ETFE Cable, Max. 284 °F	
	..15H.. = 0.2...50 LPM ..20H.. = 0.4...100 LPM	..G6 <sup>3)</sup> .. = G 1 Male		
	..35G.. = 0.4...90 GPM ..40G.. = 0.8...170 GPM	..N9.. = 2" NPT Female		
	..35H.. = 1.5...350 LPM ..40H.. = 2.6...650 LPM	..G9.. = G 2 Male		
	<b>Accessories:</b> P/N 807.037 = 4-Pin Micro-DC Connector with 6-foot Cable P/N 807.037/5M = 4-Pin Micro-DC Connector with 16-foot Cable P/N 807.037/10M = 4-Pin Micro-DC Connector with 32-foot Cable			

<sup>1)</sup> Units of measure factory programmed: °F and PSI for GPM/GPH models, °C and bar for LPM models

<sup>2)</sup> Order code substitution for longer cables: 02 = 2 m (6 ft), 05 = 5 m (16 ft), 10 = 10 m (32 ft), 15 = 15 m (49 ft), 20 = 20 m (65 ft).  
Wall mounting brackets (brackets incl. accessories) are included in the scope of delivery.

<sup>3)</sup> Regulation (EC) No. 1935/2004 for materials and articles intended to come in contact with food. Not for connection code G9/N9.

<sup>4)</sup> Measuring range code 35 is not in conformance with DVGW 270 and WRAS guidelines.

<sup>5)</sup> Number of measuring points (standard): 5.



Order Details MIM Fitting Accessory Kits

Accessory Kit Number	Native Connection / Process Connection	Fitting Kit Type <sup>1)2)</sup>	Dimensions	Image
ZUB-AD2G08P08	G 1/4 Female / 1/4" NPT Male	Adapter		
ZUB-AD2U15P08	G 1/2 Cap Nut / 1/4" NPT Male	Cap Nut and Union		
ZUB-AD2G15P15	G 1/2 Female / 1/2" NPT Male	Adapter		
ZUB-AD2G15N08	G 1/2 Female / 1/4" NPT Female	Adapter		
ZUB-AD2G15N15	G 1/2 Female / 1/2" NPT Female	Adapter		
ZUB-AD2U20P15	G 3/4 Cap Nut / 1/2" NPT Male	Cap Nut and Union		
ZUB-AD2G20P20	G 3/4 Female / 3/4" NPT Male	Adapter		
ZUB-AD2G20N15	G 3/4 Female / 1/2" NPT Female	Adapter		

<sup>1)</sup> All Fitting Kits Include 2x Fittings and 2x Klinger SIL® Flat Sealing Gaskets

<sup>2)</sup> Adapters and Unions are 316L SS, Cap Nuts are 304 SS

Order Details MIM Fitting Accessory Kits (Continued)

Accessory Kit Number	Native Connection/ Process Connection	Fitting Kit Type <sup>1)2)</sup>	Dimensions	Image
ZUB-AD2G20N20	G 3/4 Female/ 3/4" NPT Female	Adapter		
ZUB-AD2U25P15	G 1 Cap Nut/ 1/2" NPT Male	Cap Nut and Union		
ZUB-AD2U25P20	G 1 Cap Nut/ 3/4" NPT Male	Cap Nut and Union		
ZUB-AD2G25N15	G 1 Female/ 1/2" NPT Female	Adapter		
ZUB-AD2G25N20	G 1 Female/ 3/4" NPT Female	Adapter		
ZUB-AD2G25N25	G 1 Female/ 1" NPT Female	Adapter		
ZUB-AD2G25T25	G 1 Female/ 1" Tri-Clamp®	Adapter		
ZUB-AD2G50T50	G 2 Female/ 2" Tri-Clamp®	Adapter		

<sup>1)</sup> All Kits Include 2x Fittings and 2x Klingler SIL Gaskets except Kit Number ZUB-AD2G50T50 that Includes 2x Fittings and 2x FKM O-rings

<sup>2)</sup> Adapters and Unions are 316L SS, Cap Nuts are 304 SS



## Magnetic Inductive Flowmeter, All-Metal Design Model MIM

### Accessories (Spare Part)

Model	Description	Image	
ERS-ZOK-023618	Stainless Steel Wall Mounting Kit for Remote Version (2 Brackets with mounting hardware)		
Model	Description	Dimensions	Image
ZUB-MIM225128	Clamping Bracket Set for Wall Mounting (Stainless Steel with Partial Polyolefin Sleeve)	<p>0.59"x0.26" 3.94" 0.47"</p>	

### Electrical Connection MIM-..C3T

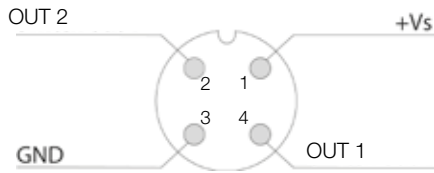

### Configuration of Outputs

Output 1 (OUT1, PIN 4)	Output 2 (OUT2, PIN 2)
Analog Output 0-10 V <sub>DC</sub>	Analog Output 0-10 V <sub>DC</sub>
Analog Output 4-20 mA	Analog Output 4-20 mA
Switching Output NPN/PNP/PP	Switching Output NPN/PNP/PP
Pulse Output PP	Pulse Output PP
Frequency Output PP	Frequency Output PP
Communication Mode KofiCom	
Communication Mode IO-Link	
Control Input	
Control Input Start/Stop/Reset Batching Function	Batching Function Switch/PP

### Pressure Loss Diagram

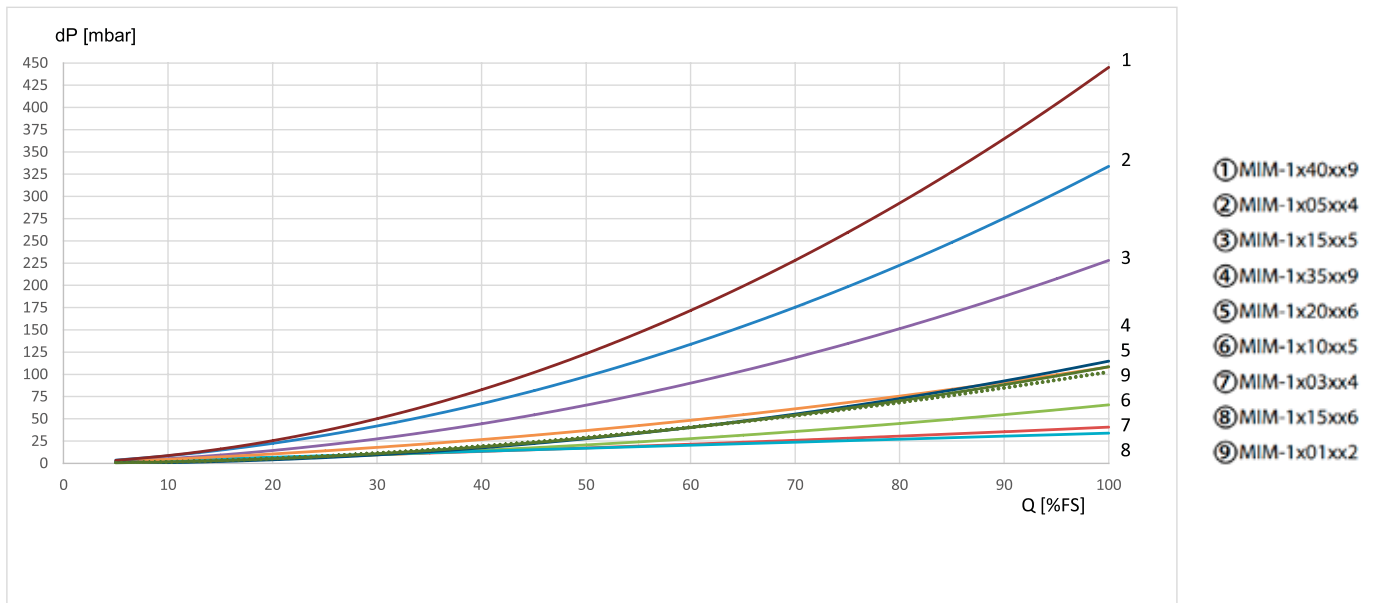



**Measuring Mode: Display Layout "Single" Configurable**

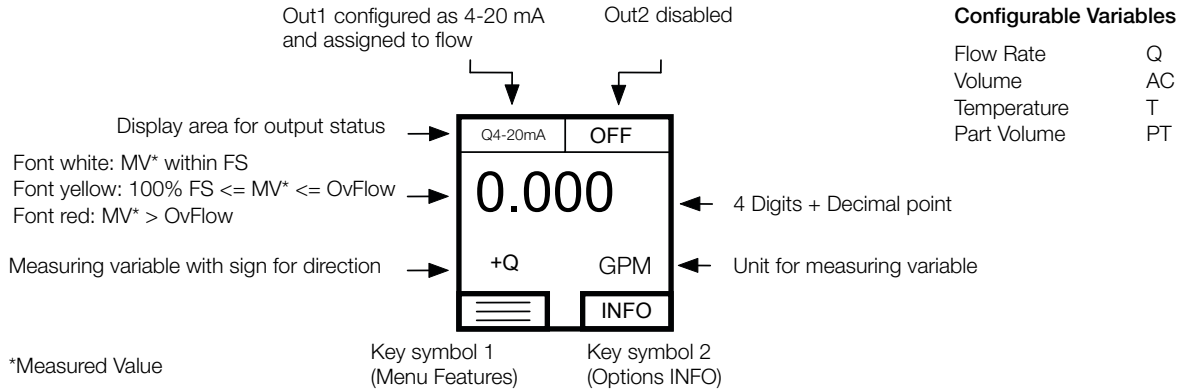

**Measuring Mode: Display Layout "Dual" Configurable**

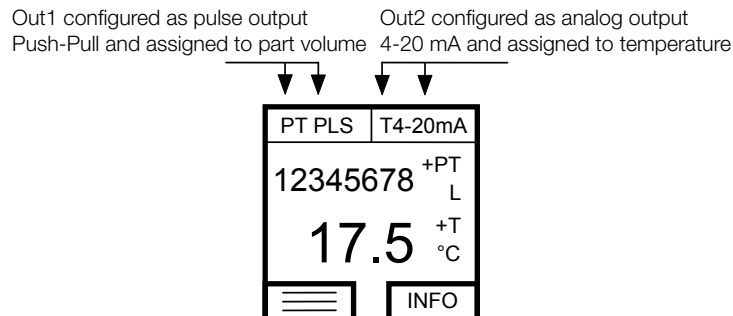
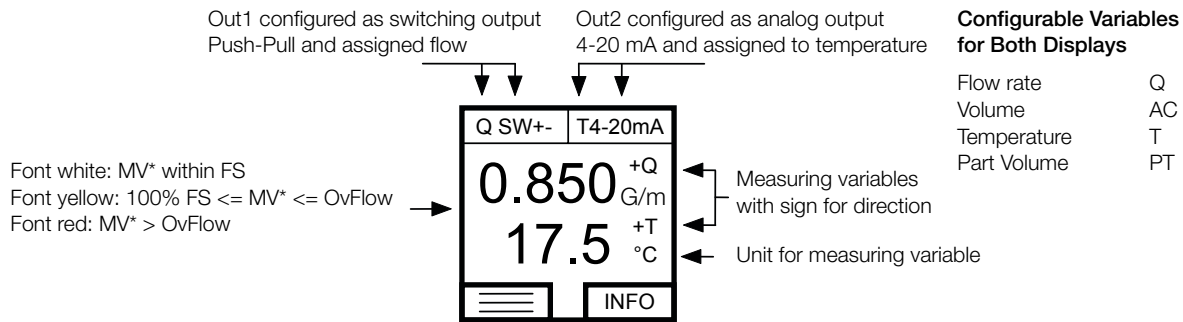



Magnetic Inductive Flowmeter, All-Metal Design Model MIM

Dimensions

Compact Version

G
1/4
1/2
3/4
1

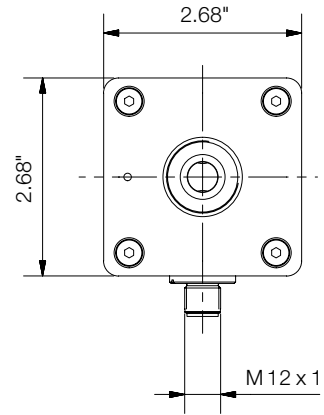
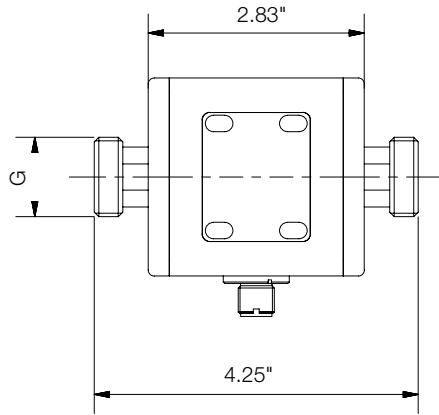

NPT
1/2
3/4
1

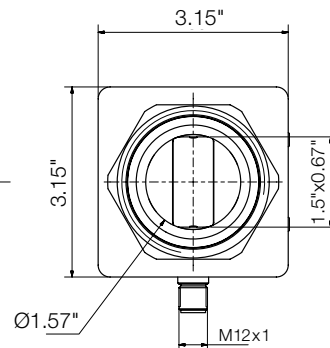
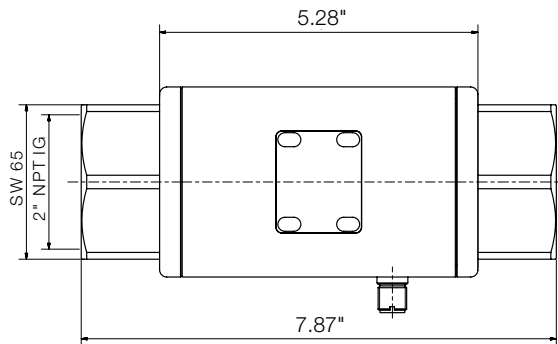
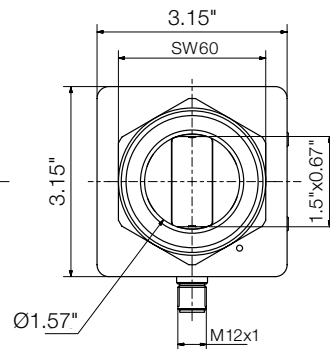
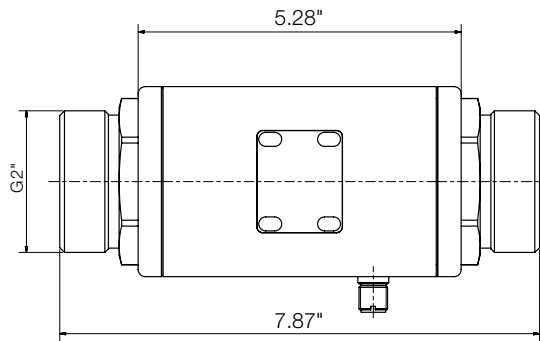
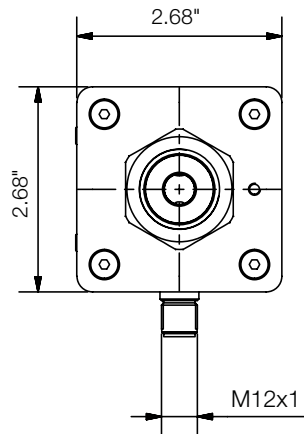
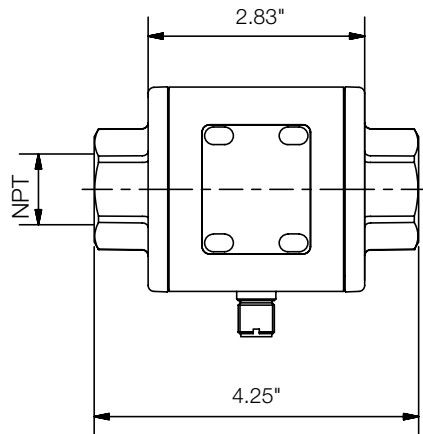

Dimensions (Continued)

Remote Version without Wall Mounting Brackets

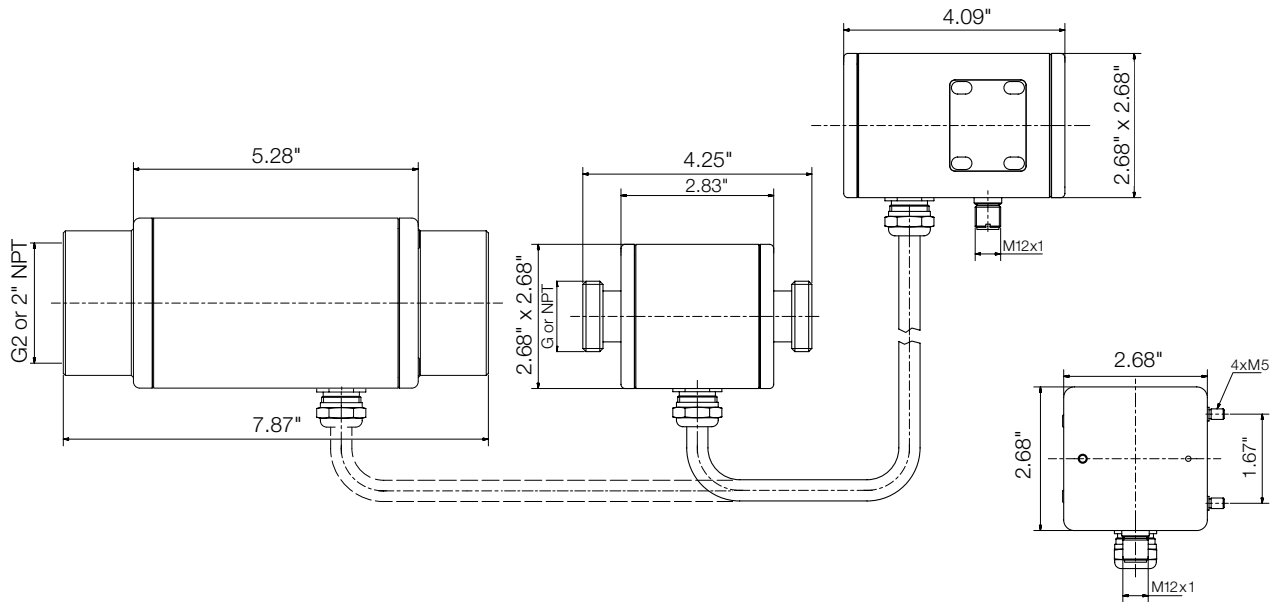

Remote Version with Wall Mounting Brackets

