

All-Metal Armored Flowmeter and Counter for Liquids and Gases



measuring
•
monitoring
•
analyzing

BGN



- 316 Stainless Steel, PTFE-Lined Stainless Steel, and Hastelloy® C-22 Measuring Tubes
- Line Sizes up to 6"
- Direct Reading Scales Calibrated for Media Viscosity, Density, Operating Pressure and Temperature
- Analog Output, HART®, and Profibus®-PA
- Connection: 1/4" ...2" NPT, ANSI 1/2" ...6", Others Available
- Special Versions Available for Process Temperatures up to 660 °F
- Special Materials: Monel®, Tantalum, Others on Request



KOBOLD companies worldwide:

ARGENTINA, AUSTRALIA, AUSTRIA, BELGIUM, BULGARIA, CANADA, CHILE, CHINA, COLOMBIA, CZECH REPUBLIC, EGYPT, FRANCE, GERMANY, HUNGARY, INDIA, INDONESIA, ITALY, MALAYSIA, MEXICO, NETHERLANDS, PERU, POLAND, REPUBLIC OF KOREA, ROMANIA, SINGAPORE, SPAIN, SWITZERLAND, TAIWAN, THAILAND, TUNISIA, TURKEY, UNITED KINGDOM, USA, VIETNAM

KOBOLD Instruments, Inc.
1801 Parkway View Drive
Pittsburgh, PA 15205
Main Office:
1.800.998.1020
1.412.788.4890
info@koboldusa.com
www.koboldusa.com

Description

The KOBOLD BGN armored variable area flowmeter is ideal for difficult applications that require high pressure capability, high temperature operation, or low pressure loss. The BGN's standard design is available in stainless steel, PTFE-clad stainless steel, or Hastelloy® C-22. The standard BGN is well suited for water, most viscous liquids, and compressed gases in line sizes up to 6". The direct reading scales are calibrated for media viscosity, density, operating pressure, and temperature. Electronic limit switches and an analog flow transmitter are available as options and are able to operate via intrinsically safe methods of protection and may be used in hazardous areas where intrinsically safe installations are permitted. Custom designs for high pressure, high temperature, special fittings, and special materials (such as Monel® and tantalum) are available. Other options include: self-draining flow bodies, gas or liquid damping, and a flow counter module.

Technical Details

Sensor

- Wetted Materials:** 316 L SS / 316-Ti SS, Hastelloy® C-22/C4, PTFE
Other Materials on Request
- Process Connection:** ASME B16.5, NPT,
Other Connections on Request
- Nominal Pressure:** 580 PSIG, ASME CI150 / 300 (Standard) (BGN-S/H)
230 PSIG, ASME CI150 (Standard) (BGN-P)
Higher Pressures Upon Request (Max. 8700 PSIG)
- Process Temperature:** -40...392 °F (BGN-S/H without Electr. Output)
-40...300 °F (BGN-S/H with Electr. Output)
-40...660 °F (BGN-S/H with Option V / H / W)
-40...257 °F (BGN-P)
- Ambient Temperature:** -40...176 °F

Accuracy

- Liquid:** ± 1.6% of Full Scale (BGN-S/H)
± 2.0% of Full Scale (BGN-P)
- Gas:** ± 1.8% of Full Scale (BGN-S/H)
± 2.2% of Full Scale (BGN-P)

Additional Inaccuracy with Transmitter (ES): ± 0.2%

Repeatability: ± 0.5% of Full Scale

Protection: IP 65 (Aluminum Housing)
IP 67 (Stainless Steel Housing)

Certification

- Explosion Protection:** BVS 03 ATEX H/B 112
- CE-Marking:** Pressure Equipment Directive 97/23/Eg



Display

- Material:** Aluminum (Stove-Enameled)
Stainless Steel (as Option)
- Electrical Outputs:** Inductive Switch, SJ 3,5-N NAMUR (Standard)*
Inductive Switch, SJ 3,5-SN NAMUR (Safety Design)* on Request
Microswitch*
Others on Request
- Ambient Temperature:** -40...176 °F (without Limit Switch)
-40...149 °F (with Limit Switch)

* Using the segments of the slot-type initiators or the eccentric discs of the microswitches, any switching point between 10 % and 90 % of the flow rate can be set.

Transmitter

- ES with HART®-Protocol
- ES with HART®-Protocol and 2 NAMUR-Switches*
- ES with HART®-Protocol and 1 NAMUR-Switch* / 1 Pulse Output
- ES with Profibus® PA
- ES with HART®-Protocol and Counter Module
- ES with Fieldbus® Foundation™

* Contact can be configured using HART®

- Power Supply:** 14 - 30 V_{DC}
- Output:** Passive, Galvanically Isolated
- Current:** 4-20 mA
- Binary 1 and 2:** U_i = 30 V, I_i = 20 mA, P_i = 100 mW
- Input Binary:** Counter Reset (only for ES with Counter Module)
- Ambient Temperature:** -40...158 °F

Certification

- Explosion Protection:** DMT 00 ATEX E 075
- Type of Protection:**  II 2G EEx ia IIC T6
- CE-Marking:** Explosion Protection Directive 94/9/EG



***Additional Information Required for Order:**

To ensure proper operation, these products require a completed application guide form to be submitted with any order. Please refer to the end of this datasheet in order to obtain the correct form. You can also contact your KOBOLD representative for this form.

Order Details for Low Flow Models: (Example: BGN-S10 201R A 0000 S 1 0 0K)

Low Flow Models						Part Number Continued
Measuring Ranges: 0.0022...0.022 GPM to 0.0176...0.176 GPM						
Model	Measuring Tube Material	Connection	Measuring Range*			
			Code	Water	Air	
BGN-..	..S10.. = Stainless Steel	..201R ^{5) 11)} .. = 1/2" Class 150 RF ASME	..A..	BGN-S10: 0.0022...0.022 GPM BGN-P10: 0.0031...0.031 GPM	0.008...0.08 SCFM	To complete part number, please go directly to order table on page 7.
		..221R ^{5) 11)} .. = 1/2" Class 300 RF ASME	..B..	BGN-S10: 0.0044...0.044 GPM BGN-P10: 0.0053...0.053 GPM	0.018...0.18 SCFM	
		..202R.. = 3/4" Class 150 RF ASME	..C..	BGN-S10: 0.0071...0.071 GPM BGN-P10: 0.0088...0.088 GPM	0.085...0.282 SCFM	
		..222R ¹⁾ .. = 3/4" Class 300 RF ASME	..D ⁵⁾ ..	0.011...0.11 GPM	0.044...0.44 SCFM	
		..203R.. = 1" Class 150 RF ASME	..E ⁵⁾ ..	0.0176...0.176 GPM	0.077...0.77 SCFM	
		..223R ¹⁾ .. = 1" Class 300 RF ASME				

*Reference Conditions: Water at 68 °F @ 1 mPas, Air at 68 °F @ 0 PSIG (Range Values for Other Media Upon Request)

Order Details for DN15 Models: (Example: BGN-S15 201R F 0000 S 1 0 0K)

DN15 Models						Part Number Continued
Measuring Ranges: 0.022...0.22 GPM to 0.264...2.64 GPM						
Model	Measuring Tube Material	Connection	Measuring Range*			
			Code	Water	Air	
BGN-..	..S15.. = Stainless Steel	..201R ^{5) 11)} .. = 1/2" Class 150 RF ASME	..F..	0.022...0.22 GPM	0.088...0.88 SCFM	To complete part number, please go directly to order table on page 7.
		..221R ^{5) 11)} .. = 1/2" Class 300 RF ASME	..G..	0.031...0.31 GPM	0.118...1.24 SCFM	
		..202R.. = 3/4" Class 150 RF ASME	..H..	0.044...0.44 GPM	0.176...1.76 SCFM	
	..P15.. = Stainless Steel Measuring Tube, PTFE-Lining	..222R ¹⁾ .. = 3/4" Class 300 RF ASME	..I..	0.071...0.71 GPM	0.294...2.71 SCFM	
		..203R.. = 1" Class 150 RF ASME	..J..	0.11...1.1 GPM	0.412...4.12 SCFM	
		..223R ¹⁾ .. = 1" Class 300 RF ASME	..K..	0.176...1.76 GPM	0.589...6.47 SCFM	
	..H15.. = Hastelloy® C-22	..6010 ^{5) 6)} .. = 1/4" NPT	..L..	0.264...2.64 GPM	1.0...10.0 SCFM	
		..6020 ^{5) 6)} .. = 3/8" NPT				
		..6030 ^{5) 6)} .. = 1/2" NPT				
		..6040 ^{5) 6)} .. = 3/4" NPT				

*Reference Conditions: Water at 68 °F @ 1 mPas, Air at 68 °F @ 0 PSIG (Range Values for Other Media Upon Request)

- ¹⁾ Pressure stated for models BGN-S and BGN-H
- ²⁾ Damping / spring not available
- ³⁾ Only available with forward advanced indicating housing
- ⁴⁾ Not available with heating / cooling
- ⁵⁾ Not for model BGN-P
- ⁶⁾ Not for model BGN-H
- ⁷⁾ Not for model BGN-S
- ⁹⁾ Cannot be converted for other media
- ¹⁰⁾ IEC 61508-2:2010 conformity confirmed by EXIDA
- ¹¹⁾ Reduced raised face



All-Metal Armored Flowmeter and Counter Model BGN

***Additional Information Required for Order:**

To ensure proper operation, these products require a completed application guide form to be submitted with any order. Please refer to the end of this datasheet in order to obtain the correct form. You can also contact your KOBOLD representative for this form.

Order Details for DN25 Models: (Example: BGN-S25 202R M 0000 S 1 0 0K)

DN25 Models						Part Number Continued
Measuring Ranges: 0.44...4.4 GPM to 1.76...17.6 GPM						
Model	Measuring Tube Material	Connection	Measuring Range*			
			Code	Water	Air	
BGN-..	..S25.. = Stainless Steel	..202R ⁵⁾ 11).. = 3/4" Class 150 RF ASME	..M..	0.44...4.4 GPM	1.76...17.6 SCFM	To complete part number, please go directly to order table on page 7.
		..222R ⁵⁾ 11).. = 3/4" Class 300 RF ASME				
	..P25.. = Stainless Steel Measuring Tube, PTFE-Lining	..203R.. = 1" Class 150 RF ASME	..N..	0.705...7.05 GPM	2.35...27.1 SCFM	
		..223R ¹⁾ 1).. = 1" Class 300 RF ASME				
	..H25.. = Hastelloy [®] C-22	..6010 ⁵⁾ 6).. = 1/4" NPT	..P..	1.1...11 GPM	4.12...41.2 SCFM	
		..6020 ⁵⁾ 6).. = 3/8" NPT				
		..6030 ⁵⁾ 6).. = 1/2" NPT				
		..6040 ⁵⁾ 6).. = 3/4" NPT				

*Reference Conditions: Water at 68°F @1 mPas, Air at 68 °F @ 0 PSIG (Range Values for Other Media Upon Request)

Order Details for DN40 Models: (Example: BGN-S40 205R P 0000 S 1 0 0K)

DN40 Models						Part Number Continued
Measuring Ranges: 1.1...11 GPM to 2.64...26.4 GPM						
Model	Measuring Tube Material	Connection	Measuring Range*			
			Code	Water	Air	
BGN-..	..S40.. = Stainless Steel	..205R.. = 1-1/2" Class 150 RF ASME	..P..	1.1...11 GPM	4.12...41.2 SCFM	To complete part number, please go directly to order table on page 7.
		..225R ¹⁾ 1).. = 1-1/2" Class 300 RF ASME				
	..H40.. = Hastelloy [®] C-22	..6040 ⁶⁾ 6).. = 3/4" NPT	..Q..	1.76...17.6 GPM	6.47...64.7 SCFM	
		..6050 ⁶⁾ 6).. = 1" NPT				
	..6060 ⁶⁾ 6).. = 1-1/4" NPT	..R..	2.64...26.4 GPM	10...100 SCFM		

*Reference Conditions: Water at 68°F @1 mPas, Air at 68 °F @ 0 PSIG (Range Values for Other Media Upon Request)

- ¹⁾ Pressure stated for models BGN-S and BGN-H
- ²⁾ Damping / spring not available
- ³⁾ Only available with forward advanced indicating housing
- ⁴⁾ Not available with heating / cooling
- ⁵⁾ Not for model BGN-P
- ⁶⁾ Not for model BGN-H
- ⁷⁾ Not for model BGN-S
- ⁹⁾ Cannot be converted for other media
- ¹⁰⁾ IEC 61508-2:2010 conformity confirmed by EXIDA
- ¹¹⁾ Reduced raised face



***Additional Information Required for Order:**

To ensure proper operation, these products require a completed application guide form to be submitted with any order. Please refer to the end of this datasheet in order to obtain the correct form. You can also contact your KOBOLD representative for this form.

Order Details for DN50 Models: (Example: BGN-S50 206R Q 0000 S 1 0 0K)

DN50 Models						Part Number Continued
Measuring Ranges: 1.76...17.6 GPM to 11...110 GPM						
Model	Measuring Tube Material	Connection	Measuring Range*			
			Code	Water	Air	
BGN-..	..S50.. = Stainless Steel	..206R.. = 2" Class 150 RF ASME	..Q..	1.76...17.6 GPM	6.47...64.7 SCFM	
			..R..	2.64...26.4 GPM	10...100 SCFM	
	..P50.. = Stainless Steel Measuring Tube, PTFE-Lining	..226R ¹⁾ .. = 2" Class 300 RF ASME	..S..	4.4...44 GPM	17.07...170.7 SCFM	
			..T..	7.05...70.5 GPM	27.07...270.7 SCFM	
	..H50.. = Hastelloy [®] C-22	..6070 ⁵⁾ .. = 1-1/2" NPT	..U ⁹⁾ ..	11...110 GPM	41.19...411.9 SCFM	
	..6080 ⁵⁾ .. = 2" NPT					

*Reference Conditions: Water at 68°F @1 mPas, Air at 68 °F @ 0 PSIG (Range Values for Other Media Upon Request)

Order Details for DN80 Models: (Example: BGN-S80 208R T 0000 S 1 0 0K)

DN80 Models						Part Number Continued
Measuring Ranges: 7.05...70.5 GPM to 17.61...176.1 GPM						
Model	Measuring Tube Material	Connection	Measuring Range*			
			Code	Water	Air	
BGN-..	..S80.. = Stainless Steel	..208R.. = 3" Class 150 RF ASME	..T..	7.05...70.5 GPM	27.07...270.7 SCFM	
			..U..	11...110 GPM	41.19...411.9 SCFM	
	..P80.. = Stainless Steel Measuring Tube, PTFE-Lining	..228R ¹⁾ .. = 3" Class 300 RF ASME	..V ⁵⁾ ..	17.61...176.1 GPM	64.74...647.4 SCFM	
..H80.. = Hastelloy [®] C-22						

*Reference Conditions: Water at 68°F @1 mPas, Air at 68 °F @ 0 PSIG (Range Values for Other Media Upon Request)

- ¹⁾ Pressure stated for models BGN-S and BGN-H
- ²⁾ Damping / spring not available
- ³⁾ Only available with forward advanced indicating housing
- ⁴⁾ Not available with heating / cooling
- ⁵⁾ Not for model BGN-P
- ⁶⁾ Not for model BGN-H
- ⁷⁾ Not for model BGN-S
- ⁹⁾ Cannot be converted for other media
- ¹⁰⁾ IEC 61508-2:2010 conformity confirmed by EXIDA



All-Metal Armored Flowmeter and Counter Model BGN

***Additional Information Required for Order:**

To ensure proper operation, these products require a completed application guide form to be submitted with any order. Please refer to the end of this datasheet in order to obtain the correct form. You can also contact your KOBOLD representative for this form.

Order Details for DN100 Models: (Example: **BGN-S1H 210R V 0000 S 1 0 0K**)

DN100 Models						Part Number Continued
Measuring Ranges: 17.61...176.1 GPM to 44.03...440.3 GPM						
Model	Measuring Tube Material	Connection	Measuring Range*			
			Code	Water	Air	
BGN-..	..S1H.. = Stainless Steel	..210R.. = 4" Class 150 RF ASME	..V..	17.61...176.1	64.74...647.4	To complete part number, please go directly to order table on page 7.
	..P1H.. = Stainless Steel Measuring Tube, PTFE-Lining		..W..	BGN-S/H: 26.42...264.2 GPM BGN-P: 24.21...242.1 GPM	on Request	
	..H1H.. = Hastelloy® C-22		..X ⁵⁾ ..	35.23...352.3 GPM	on Request	
			..2 ²⁾⁵⁾ ..	44.03...440.3 GPM	on Request	

*Reference Conditions: Water at 68 °F @1 mPas, Air at 68 °F @ 0 PSIG (Range Values for Other Media Upon Request)

Order Details for DN150 Models: (Example: **BGN-SH5 212R 2 0000 V 1 0 0K**)

DN150 Models						Part Number Continued
Measuring Ranges: 17.61...176.1 GPM to 44.03...440.3 GPM						
Model	Measuring Tube Material	Connection	Measuring Range*			
			Code	Water	Air	
BGN-..	..SH5.. = Stainless Steel	..212R ¹⁾ .. = 6" Class 150 RF ASME	..2 ⁵⁾ ..	44.03...440.3 GPM	on Request	To complete part number, please go directly to order table on page 7.
	..HH5.. = Hastelloy® C-22	..232R ⁹⁾¹¹⁾ .. = 6" Class 300 RF ASME	..4 ⁵⁾ ..	57.24...572.2 GPM	on Request	

*Reference Conditions: Water at 68 °F @1 mPas, Air at 68 °F @ 0 PSIG (Range Values for Other Media Upon Request)

¹⁾ Pressure stated for models BGN-S and BGN-H

²⁾ Damping / spring not available

³⁾ Only available with forward advanced indicating housing

⁴⁾ Not available with heating / cooling

⁵⁾ Not for model BGN-P

⁶⁾ Not for model BGN-H

⁷⁾ Not for model BGN-S

⁹⁾ Cannot be converted for other media

¹⁰⁾ IEC 61508-2:2010 conformity confirmed by EXIDA

¹¹⁾ Models from 4" Class 300 and up require selection of display "assembled at distance". Choose display option codes: "V", "H", or "W"



***Additional Information Required for Order:**

To ensure proper operation, this product requires a completed application guide form to be submitted with any order. Please refer to the end of this datasheet in order to obtain the correct form. You can also contact your KOBOLD representative for this form.

Order Details Continued** (Example: BGN-S 10 201R A 0000 S 1 0 0 K)

Heating ⁵⁾ / Cooling	Damping ⁵⁾ / Spring Stop	Draining Body	Certificates	Display	Scale	Electrical Output	Accessories
<p>..0.. = without</p> <p>..3.. = with Heating ANSI-Flange 1/2" Class 150</p> <p>..4.. = with Heating 1/2" NPT Conn.</p>	<p>..0.. = without</p> <p>..R⁶⁾.. = with Flow Restrictor for Gas Measuring</p> <p>..F¹¹⁾.. = with Liquid Damping</p> <p>..G¹¹⁾.. = with Gas Damping</p> <p>..A¹¹⁾.. = with Spring Stop</p> <p>..S¹¹⁾.. = with Gas Damping and Spring Stop</p>	<p>..0.. = without</p> <p>..L¹²⁾.. = with Self Draining Body</p>	<p>..0.. = without Certificate</p> <p>..1.. = Certificate of Compliance with the Order 2.1</p> <p>..2.. = Test Report 2.2</p> <p>..B.. = Inspection Certificate with Material Certificate 3.1</p> <p>..C.. = Inspection Certificate with Material Certificate 3.2</p>	<p>..S¹³⁾.. = Aluminum</p> <p>..V.. = Aluminum, Assembled at Distance, up to 660 °F</p> <p>..E¹³⁾.. = Stainless Steel</p> <p>..H.. = Stainless Steel, Assembled at Distance, up to 660 °F</p> <p>..T¹³⁾.. = Aluminum with Pressure Compensation</p> <p>..W.. = Aluminum with Pressure Compensation, Assembled at Distance, up to 660 °F</p>	<p>Water</p> <p>..1.. = %-Scale</p> <p>..2.. = Measuring Range</p> <p>Media</p> <p>..4.. = %-Scale</p> <p>..5.. = Measuring Range</p> <p>..F.. = Dual Scale</p> <p>**Please specify media data in plain text (see below)</p>	<p>..0.. = without</p> <p>..1.. = 1 Inductive Limit Switch, SIL-1¹⁰⁾</p> <p>..2.. = 2 Inductive Limit Switches, SIL-1¹⁰⁾</p> <p>..C.. = 1 Micro Switch</p> <p>..D.. = 2 Micro Switches</p> <p>..6.. = Transmitter ES with HART[®], EEx ia, 4-20 mA, SIL-1⁹⁾</p> <p>..7.. = Transmitter ES with HART[®], EEx ia, 4-20 mA and 2 NAMUR-Switches, SIL-1¹⁰⁾</p> <p>..8.. = Transmitter ES with HART[®], EEx ia, 4-20 mA, 1 NAMUR-Switch and 1 Pulse Output, SIL-1¹⁰⁾</p> <p>..9.. = Electrical Transmitter ES with Profibus[®] PA, EEx ia</p> <p>..I.. = 4-20 mA with HART[®] and Counter Module</p> <p>..K.. = Electrical Transmitter ES with Fieldbus[®] Foundation™</p>	<p>..0K = Without</p> <p>..XK = Special (Please Specify)</p>

¹⁾ Pressure stated for models BGN-S and BGN-H
²⁾ Damping / spring not available
³⁾ Only available with forward advanced indicating housing
⁴⁾ Not available with heating / cooling
⁵⁾ Not for model BGN-P
⁶⁾ Not for model BGN-H
⁷⁾ Not for model BGN-S
⁸⁾ Only available up to range code "E" (0.077...0.77 SCFM)
⁹⁾ Cannot be converted for other media
¹⁰⁾ IEC 61508-2:2010 conformity confirmed by EXIDA
¹¹⁾ Not for "Low Flow" or DN150 (6") models
¹²⁾ Not for "Low Flow" models
¹³⁾ Not for DN100 4" with 300lb ANSI, all DN100 5" ANSI, or all DN150 6" models



Dimensions

Aluminum Display

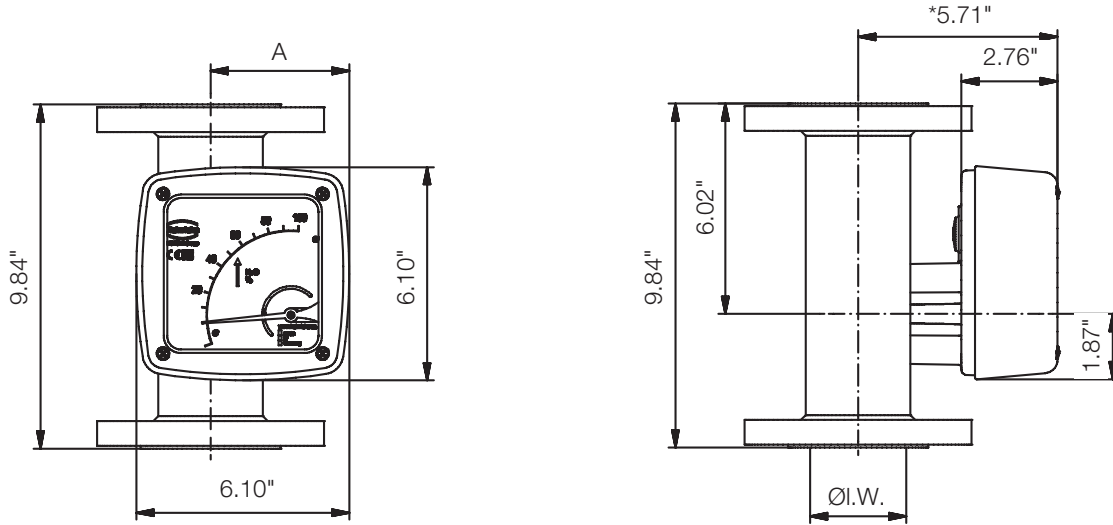

Stainless Steel Display

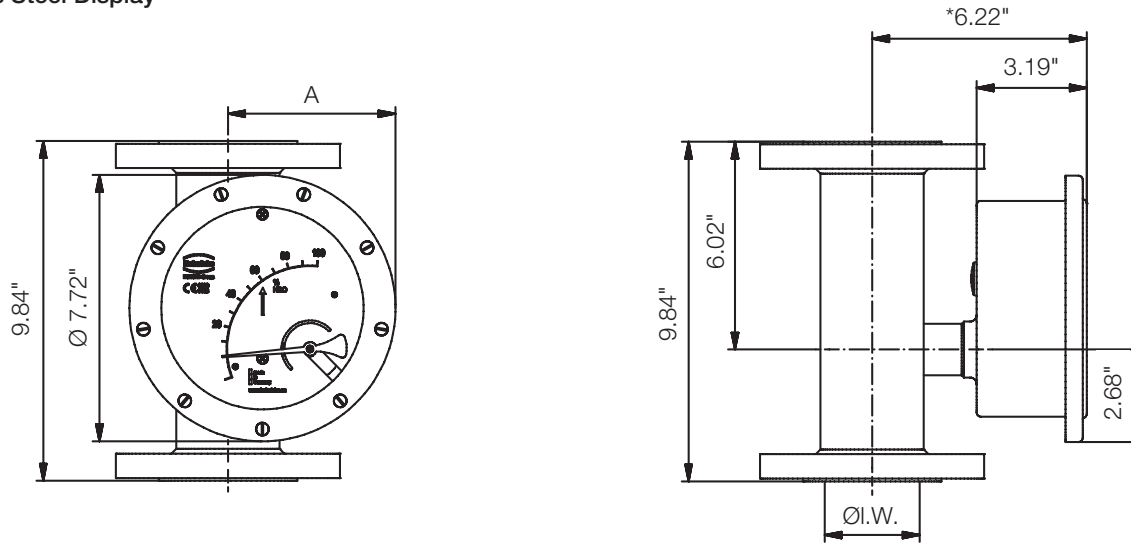

DN	PN	I. W. (Inner Width)	A	
			Aluminum Display	Stainless Steel Display
15	40	1.02"	2.91"	3.94"
25	40	1.26"	3.03"	4.06"
40	40	1.81"	3.35"	4.33"
50	40	2.76"	3.86"	4.84"
80	40	4.02"	4.62"	5.51"
100	16	4.92"	5.00"	6.02"
125	16	5.91"	5.59"	6.54"
150	16	6.26"	5.83"	6.73"

Dimensional Deviations:

* + 3.94" with forward advanced display and generally at DN 150



BGN Application Guide

Rev 08/30/2021

General Information

Contact Name: _____
 Company Name: _____
 Phone: _____
 Email: _____
 Quote Number (if already quoted): _____

Date: _____
 Part Number: _____
 Calibrated Range: _____
 Number of Pieces Required: _____

This has not been quoted yet and pricing is required.

Design Conditions

Accurate design pressure and temperature are essential to ensure the flowmeter will be built to operate without damage. Please fill out accurately and completely.

1. Pressure: Maximum _____ PSIG
2. Temperature: Maximum _____ °F

Calibration Conditions for Liquid Flow Applications

1. Type of Liquid: _____
2. Normal Operating Temperature: _____ °F
3. Viscosity at Normal Operating Temperature: _____
4. Specific Gravity (at Normal Operating Temp): _____
5. Desired Measuring Range and Units: _____

Note: Items 3 & 4 not required for water flow

Note: Item 5 is subject to sizing program and ranges on datasheet.

Calibration Conditions for Gas Flow Applications

1. Type of Gas: _____
2. Normal Operating Temperature: _____ °F
3. Normal Pressure at Outlet Fitting: _____ PSIG
4. Viscosity at Normal Operating Temp: _____
5. Specific Gravity (required for gas mixtures): _____
6. Desired Measuring Range and Units: _____

Note: The calibration pressure required is the pressure that the meter sees at its outlet fitting.

Measuring Tube Options

1. Measuring Tube Material: 316 Stainless Steel PTFE Lined Stainless Steel Hastelloy C-22
 Other (specify): _____
2. Desired Fitting Size: 1/2" 3/4" 1" 1-1/2" 2" 3" 4" 5" 6"
3. Fitting Type: NPT Thread (2" max) 150 LB ANSI Flange 300 LB ANSI Flange
 Other (specify): _____
4. Heating/Cooling Jacket: None 1/2" NPT Connections 1/2" 150 lb. ANSI Connections
 Other Connections (specify): _____

5. Damping/Spring Stop: without with Flow Restrictor for Gas Monitoring with Liquid Damping
 with Gas Damping with Spring Stop with Gas Damping and Spring Stop
6. Draining Body: without with Self Draining Body
7. Certificates: without Cert. Cert. of Compliance 2.1 Test Report 2.2
 Inspection Cert. with Material Cert. 3.1 Inspection Cert. with Material Cert. 3.2

Indicator/Electronic Options

1. Display Housing: Aluminum High Temperature Aluminum (660 °F) Stainless Steel
 High Temperature Stainless Steel (660 °F) Aluminum with Pressure Compensation
 High Temperature Aluminum with Pressure Compensation
2. Scale: % Scale Water Measuring Range Water % Scale Media
 Measuring Range Media Dual Scale (specify): _____
3. Electrical Output: without 1x Inductive Switch 2x Inductive Switches 1x Micro-switch
 2x Micro-switches 4-20mA Transmitter with HART®
 4-20mA Transmitter with HART® & 2x NAMUR Switches
 4-20mA Transmitter with HART® & 1x NAMUR Switch & Pulse Output
 4-20mA Transmitter with Profibus® PA
 4-20mA Transmitter with HART® & Digital Totalizer
 4-20mA Transmitter with Fieldbus® Foundation™

Special Requirements or Additional Considerations:

**Once completed, please save and email this form to your KOBOLD contact or info@koboldusa.com, or fax to 412-788-4890.*