

IS-6000 Radar

Stationary non-contact flow meter for open channels and partially filled pipes

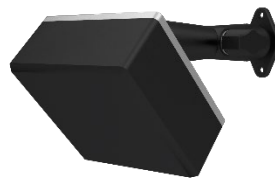

Radar velocity sensor

CONTENT

1. General information.....	1
1.1 Copyright.....	1
1.2 Data protection and security.....	1
1.3 Liability	1
1.4 EU Conformity Declaration	1
1.5 Warnings and safety symbols.....	2
1.6 Trademarks	2
2. General safety instructions.....	3
2.1 Requirements for the personnel.....	3
2.2 Intended use	3
2.3 Workplace safety.....	3
2.4 Operational safety	3
2.5 Product safety	3
2.6 Electric safety.....	4
3. Product description.....	5
3.1 Scope of delivery.....	6
3.2 Storage.....	6
3.3 Nameplate	6
3.4 Measuring system.....	7
3.4.1 Transmitter.....	7
3.4.2 Software	8
3.4.3 Sensors	8
4. Installation.....	11
4.1 Mounting of the transmitter	11
4.2 Mounting of the sensors.....	11
4.3 Calibration.....	13
5. Electrical connection.....	14
5.1 Terminal compartment.....	14
5.2 Pin assignment.....	16
5.3 Connection to external 3G/2G router.....	19
5.4 Connection of sensors	19
5.4.1 Connection of radar velocity sensor rv11	19
5.4.2 Connection of radar velocity sensor RV2411.....	20

5.4.3 Connection of external level sensors on analog input block	20
5.4.4 RS-485 /RS-232 Modbus configuration.....	23
5.5 Final check of electrical connections	23
6. Communication with transmitter.....	24
6.1 Control panel and LC-Display.....	24
6.2 Wireless communication WiFi	25
6.3 Communication to the transmitter via Ethernet LAN	26
7. Programming.....	27
7.1 Login	27
7.1.1 User groups and access rights.....	28
7.2 Menu structure	28
7.2.1 Overview of main menu items and function of corresponding submenus.....	30
7.2.2 Settings for language and location	32
7.3 Home – Overview.....	33
7.4 Graph - Data visualization.....	34
7.4.1 3 days.....	35
7.4.2 Current.....	37
7.4.3 History.....	38
7.4.4 Settings.....	39
7.5 Download - Data transfer.....	40
7.5.1 Download	40
7.5.2 Setting.....	42
7.6 Parameter – Parameterization	43
7.6.1 Geometry.....	43
7.6.2 Sludge Level	48
7.6.3 Water level.....	48
7.6.4 Measurement Range.....	49
7.6.5 Calibration.....	53
7.6.6 Replacement	54
7.7 I/Os – Digital and analog in- and outputs.....	58
7.7.1 Analog in.....	58
7.7.2 Analog out.....	60
7.7.3 Digital in.....	61
7.7.4 Digital out.....	62

7.7.5 User value.....	65
7.8 Settings – Data logging and display.....	66
7.8.1 Logging.....	66
7.8.2 Units.....	67
7.8.3 Displayed Units.....	69
7.8.4 Totalizer.....	69
7.9 Communication – Network settings.....	71
7.9.1 Network.....	71
7.9.2 FTP.....	79
7.9.3 Modbus.....	80
7.9.4 Serial.....	83
7.10 Diagnosis.....	84
7.10.1 Log Files.....	84
7.10.2 Data.....	85
7.11 Extras.....	86
7.11.1 Language Location.....	86
7.11.2 Date Time.....	88
7.11.3 LC-Display.....	90
7.11.4 Power Management.....	91
7.11.5 Backup & Update.....	92
7.12 Abbreviations.....	94
8. Service.....	95
8.1 Maintenance and care.....	95
8.2 Troubleshooting.....	95
8.2.1 Error codes.....	95
8.2.2 Reset to factory settings.....	96
8.3 Technical support.....	98
8.4 Return / Repair.....	98
8.5 Disposal.....	98
9. Operating principle.....	99
9.1 Non-contact surface velocity measurement (pulse wave radar velocity).....	99
9.2 Measurement spot.....	99
10. Technical data.....	101
10.1 Transmitter.....	101

10.2 Non-contact radar velocity sensor RV11	102
10.3 Non-contact radar velocity sensor RV24	102
10.4 Ultrasonic and radar water level sensors	103
11. Annex	105
11.1 Roughness coefficients	105
11.2 Bibliography	108

1. GENERAL INFORMATION

This user manual provides all necessary information for the operation and the efficient and safe use of the Radar flowmeter. It contains important information on product identification, storage, installation, commissioning, operation, maintenance and disposal of the device. Before putting the device into operation, read this user manual carefully. To prevent possible injuries to the user and damage, use the device only for the intended use described below. Always keep this document handy in the vicinity of the device! If you do not understand the contents of this document, contact the manufacturer. In no case may Badger Meter Europa GmbH be held reliable for any damage or injury caused by misunderstanding of the information.

1.1 Copyright

All rights reserved. The contents and works in this document are subject to copyright. Contributions from third parties are identified as such. No part of this documentation may be reproduced in any form, stored or transferred, neither electronically, mechanically, phototechnically, by recording on data media, still otherwise, as long as no expressly written authorization from the publisher is present.

1.2 Data Protection and Security

All data should be backed-up prior to the installation of any peripheral storage device. Badger Meter will not be responsible for any loss of data resulting from the use or misuse of this or any other Badger Meter product. Data security is given by personated login with username and password. Data will be saved on server with appropriate security measures to ensure protection against data loss, data abuse and unauthorized data modifications. Please be advised that there are inherent security risks in transmitting data via the internet. It is not possible to safeguard completely against unauthorized access by third parties. The use of contact data published within the framework of the imprint obligation by third parties for the transmission of not expressly requested advertising and information material is hereby expressly rejected.

1.3 Liability

In case of inappropriate or unintended use, no liability for the proper function of the device can be assumed. Improper installation and operation of the device will cause the warranty to be void. Badger Meter has made every effort to ensure the accuracy of the contents of this manual and the software. However, Badger Meter can offer no guarantee that the information provided is accurate and/or free of error. The information provided in this manual is subject to change without notice at any time. Badger Meter reserves the right to alter designs, layouts or software without prior notification and will not be liable in any way for possible consequences of such changes.

1.4 EU Conformity Declaration

The manufacturer hereby declares that this product complies with Directive 2014/30/EU. The full text of the EU declaration of conformity can be found in Section 10.5 at the end of this documentation.

1.5 Warnings and Safety Symbols

Depending on the hazard level, warnings are displayed as follows.

DANGER

IMMEDIATE DANGER. INDICATES A POTENTIALLY OR IMMINENTLY HAZARDOUS SITUATION WHICH, IF NOT AVOIDED, WILL RESULT IN DEATH OR SERIOUS INJURY.

WARNING

MEDIUM RISK. INDICATES A POTENTIALLY OR IMMINENTLY HAZARDOUS SITUATION WHICH, IF NOT AVOIDED, COULD RESULT IN DEATH OR SERIOUS INJURY.

CAUTION

MINOR RISK. INDICATES A POTENTIALLY HAZARDOUS SITUATION THAT MAY RESULT IN MINOR OR MODERATE INJURY OR DAMAGE.

NOTICE!

Important handling instruction. Indicates a situation which, if not avoided, may cause damage to the device. Information that requires special emphasis.

INFORMATION!

This symbol indicates helpful notes and information for handling the device.

1.6 Trademarks

All terms and brand names used in the manual are generally subject to the trademark and patent protection of the respective companies.

2. GENERAL SAFETY INSTRUCTIONS

2.1 Requirements for the Personnel

Installation, electrical connections, commissioning, operation and maintenance of the device must be carried out by qualified, special trained and authorized personnel.

Personal injuries and serious damage to the device are caused by insufficiently qualified personnel.

Qualified personnel:

- persons, who, through their professional training and education, are familiar with the safety guidelines of electrical and automation engineering.
- persons, who, as project, commissioning, and installation personnel, are authorized to commission, ground and label circuits and devices/systems in accordance with the standards of safety engineering.
- must be able to safely assess the results of their work and must be familiar with the contents of these operating instructions.

Special trained personnel:

- persons, e.g. fitters or electricians, who can perform various tasks such as transport, assembly and installation of the product under the supervision of an authorized person. The persons must have experience in handling the product.

Authorized personnel:

- persons who are indentured to work on the basis of legal regulations or have been approved by the manufacturer for certain activities.

The following requirements must be met:

- The user manual must be read carefully and fully understood by qualified personnel. Instructions must be followed.
- Qualified personnel must be trained and authorized by the plant operator.
- During work on and with the device the required personal protective equipment must always be worn.
- All applicable national standards, safety requirements and accident prevention regulation must be observed.

2.2 Intended use



IMPROPER USE CAN SERIOUSLY COMPROMISE THE SAFETY OF THE DEVICE. THE DEVICE IS EXCLUSIVELY DESIGNED TO BE USED FOR PURPOSES AS DESCRIBED BELOW. KEEP WITHIN THE SPECIFIED PRESSURE AND TEMPERATURE RANGE WHILE USING THE DEVICE. RESISTANCE OF ALL FLUID-WETTED PARTS OF THE DEVICE AGAINST THE MEASURED FLUID MUST BE ENSURED TO AVOID CORROSION AND ABRASION.

INFORMATION!

The manufacturer is not liable for any damage resulting from improper use or use for other than the intended purpose.

The Radar is a permanent non-contact flow meter for continuous flow monitoring in open channels and for use in municipal wastewater and storm water sewers as well as hydrological applications.

2.3 Workplace safety

During work on and with the device the required personal protective equipment must always be worn. All applicable national standards, safety requirements and accident prevention regulation must be observed.

2.4 Operational safety

Operate the device in proper technical condition and fail-safe condition only. The operator is responsible for interference-free operation of the device.

2.5 Product safety

This measuring device is designed in accordance with good engineering practice to meet state-of-the-art safety requirements. It has been tested and left the factory in a condition in which it is safe to operate. It meets general safety standards and legal requirements. It also complies with the EU directives listed in the device-specific EU Declaration of Conformity.

2.6 Electric safety

WARNING

DISCONNECT DEVICE

- **SINCE THE DEVICE CANNOT BE SWITCHED OFF AT THE HOUSING, IT IS ABSOLUTELY NECESSARY TO CONNECT THE SYSTEM TO AN EXTERNAL DISCONNECTING DEVICE.**

DANGEROUS CONTACT VOLTAGES

- **THE FUNCTIONAL EARTHING IS NOT IDENTICAL TO THE PROTECTIVE EARTHING ACCORDING TO DIN VDE 0100!**
- **EMC GROUND CONNECTORS ONLY FULFIL SECONDARY MEASURES FOR PROTECTION AGAINST DANGEROUS CONTACT VOLTAGES.**
- **THE GREEN-YELLOW WIRES OF THE PROTECTIVE CONDUCTOR (PE) FULFIL THE MEASURES FOR PROTECTION AGAINST DANGEROUS CONTACT VOLTAGES, BUT NOT THE REQUIREMENTS OF EMC DIRECTIVE 2014/30/EU.**
- **WHEN EARTHING A SYSTEM, TAKE APPROPRIATE PROTECTIVE AND FUNCTIONAL MEASURES IN ACCORDANCE WITH DIN VDE 0100 AND EMC DIRECTIVE 2014/30/EU.**

WARNING

PROTECTIVE GROUNDING

SUITABLE MEASURES FOR ERROR PROTECTION MUST BE CARRIED OUT. THE CONDUCTIVE SYSTEM PARTS TO BE PROTECTED MUST BE CONNECTED TO A SUITABLE EARTHING CONDUCTOR VIA THE PE CONDUCTOR, SO THAT THE SYSTEM PARTS WITH A FAULT ARE SWITCHED OFF BY OVERCURRENT PROTECTION DEVICES.

Symbols	Description
	Protective conductor connection This symbol refers to the protective conductor connection of the device. Depending on the type of installation, the device may only be operated with a suitable protective conductor connection in accordance with the applicable laws and regulations
L	Phase conductor
N	Neutral conductor

3. PRODUCT DESCRIPTION

The Radar flow meter is a non-contact flow meter for stationary flow monitoring of slightly to heavily polluted media in open channels and rivers and in partially filled pipes. The measuring system consists of a transmitter and two non-contact sensors: a radar velocity sensor for flow velocity measurement and an ultrasonic or radar sensor for water level measurement (Fig. 1). The flow rate is calculated by multiplication of the average flow velocity and the wetted cross-sectional area (continuity equation).

Compact construction combined with the non-contact measurement principle enables an easy installation and use. Additionally, the Radar measures bi-directional flow over the entire measurement range and near zero flow velocities down to 0.05 m/s.

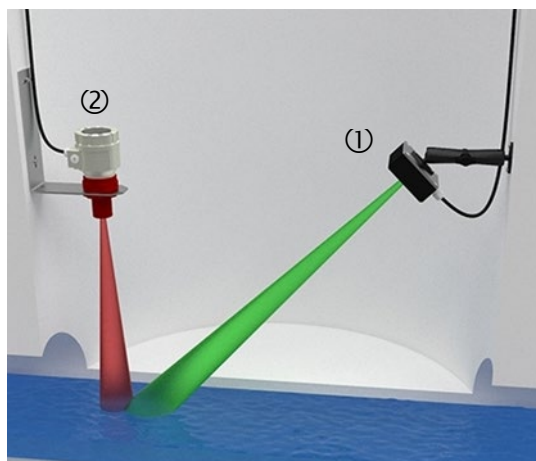

Figure 1: Combined non-contact velocity (1) and water level (2) measurement

Parameterization of the measurement site, data logging, visualisation and data transfer is possible by using the browser-based control and management user interface. The web interface can be accessed over a WiFi or LAN connection and can be run in any standard web browser via PC, notebook, tablet or smart phone, regardless of location, time and operating system.

Applications:

Continuous flow monitoring in

- Wastewater treatment plants
- Wastewater collection systems
- Storm water runoff systems
- Urban drainage
- Hydrological applications
- Industry

3.1 Scope of delivery

NOTICE!

Check the packaging and the contents for damage. Check that delivery is complete and agrees with the shipping documents and your order. If damages occurred or any items are missing, please contact Badger Meter Europa GmbH.

Scope of delivery:

- Radar transmitter
- Radar velocity sensor
- Level sensor (sensor type according to customer's order)
- User manual

Accessories / options:

- Integrated LTE/HSPA+/GPRS (4G/3G/2G) modem incl. 4G/LTE dipole antenna
- External UMTS/HSPA (3G/2G) router incl. GSM/LTE rod antenna
- Mounting systems for sensors

3.2 Storage

Store the equipment in a dry and dust-free place. Avoid durable exposure to direct sunlight. Store the device ideally in its original packaging.

Storage temperature: -20 - 70°C, ideally at 20°C.

3.3 Nameplate

INFORMATION!

Check the device nameplate to ensure that the device is delivered according to your order.

The nameplate (Fig. 2) indicates important data for identification and use of the measuring system and is located on the side of the transmitter housing.

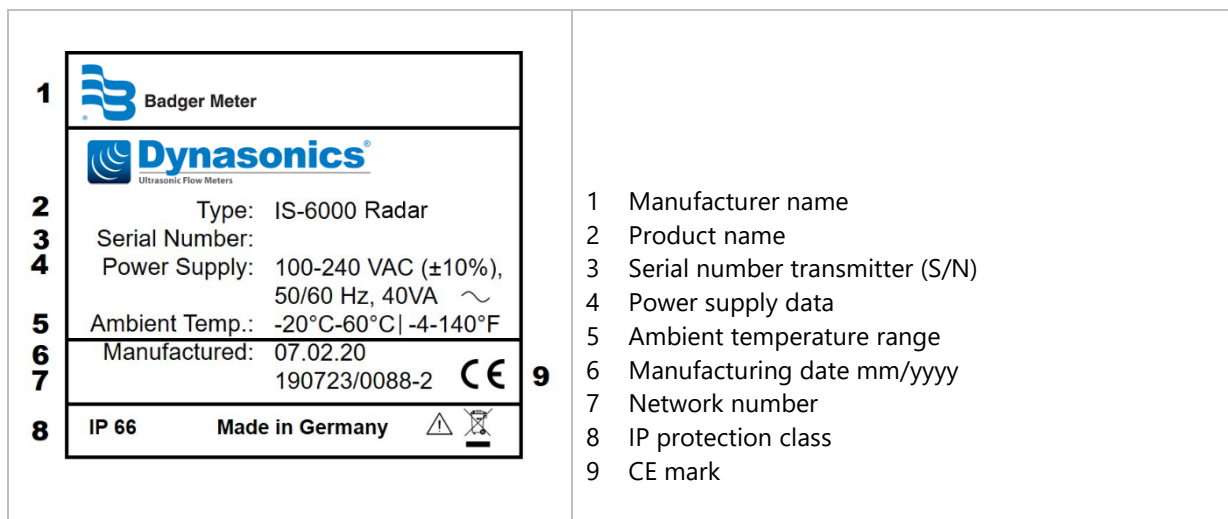

Figure 2: Nameplate (example)

3.4 Measuring System

3.4.1 TRANSMITTER

The transmitter is designed to operate radar velocity sensors and to calculate the flow rate. The flow computer incorporates all required algorithms and software to ensure accuracy and re-peatability of the measurements. The IP66 (NEMA 4X) flow display computer has a 4 lines x 20 characters alphanumeric LCD display and a 4-button keypad. It controls the measurements, calculates the flow rate and provides freely programmable current outputs, status alarm, frequency outputs and totalizer readings. All configuration data, measurement data and calculated data are stored on a 16GB Micro-SD card. Wireless communication options include WiFi or cellular connection. The Aluminium transmitter is suitable for wall mounting (Fig. 3). For cellular connection, an integrated LTE(4G)/HSPA+(3G)/GPRS(2G) modem or an external UMTS/HSPA (3G/2G) router are available. Outer connections for the transmitter with integrated modem are shown in and differ slightly from the standard enclosure type shown in Fig. 3.

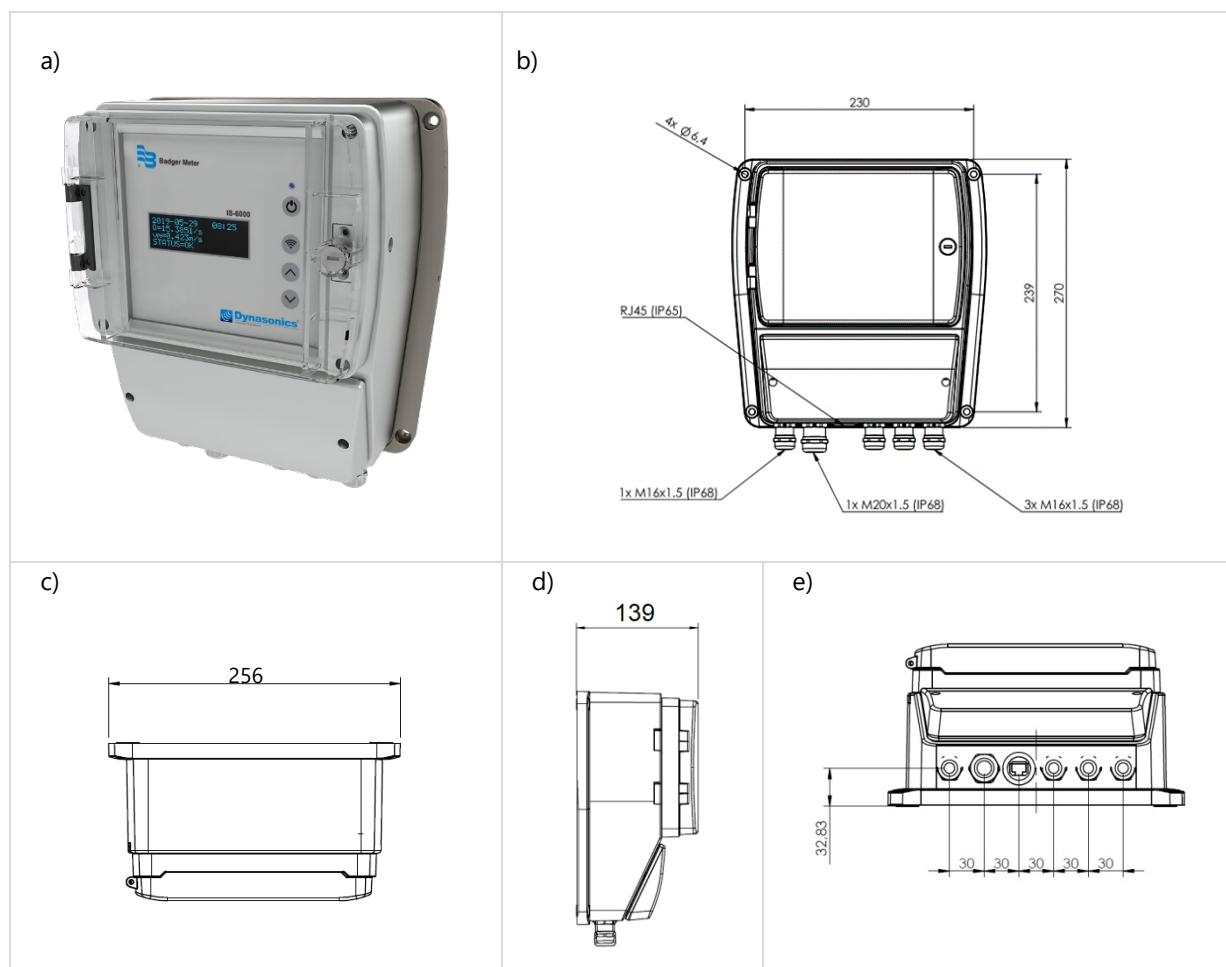

Figure 3: Overview transmitter for wall installation, dimensions (in mm)
 a), b) Front view of transmitter for wall installation,
 c), d) top view and side view,
 e) bottom view, cable entries

3.4.2 SOFTWARE

The Radar flowmeter is programmed and managed by a browser-based user interface that simply can be run via WiFi or LAN connection in any standard web browser.

The graphical user interface is menu-driven for rapid commissioning, easy parameterization of the measurement site and data visualization and management.

Main features are:

- Intuitive menu-driven user interface
- Direct communication (WiFi) with measuring system
- Automatic identification of measuring system via system-specific IP address
- Status information of measuring system, alarm functions
- Simple parameterization and commissioning of measuring system
- Flexible graphical data visualization (e.g. real-time zoomable data and time series, data history)
- Data logging of incoming data and easy data transfer
- Remote system diagnostics, service and maintenance
- Protection from unauthorized access through individual access authorization

3.4.2.1 System Requirements

- Network connection (WiFi, LAN)
- Standard latest web browser, e.g.: Internet Explorer, Firefox, Chrome, Safari, Opera, Android Browser.

3.4.3 SENSORS

Two radar velocity sensor types are available for the Radar system, specifically suitable for wastewater (RV11) or hydrological (RV24) applications.

The RV11 sensor is suitable for installation heights from 0.2-10 m above the water. The sensor type RV24 is designed for mounting heights of 0.5-20 m.

3.4.3.1 Non-contact radar velocity sensor RV11

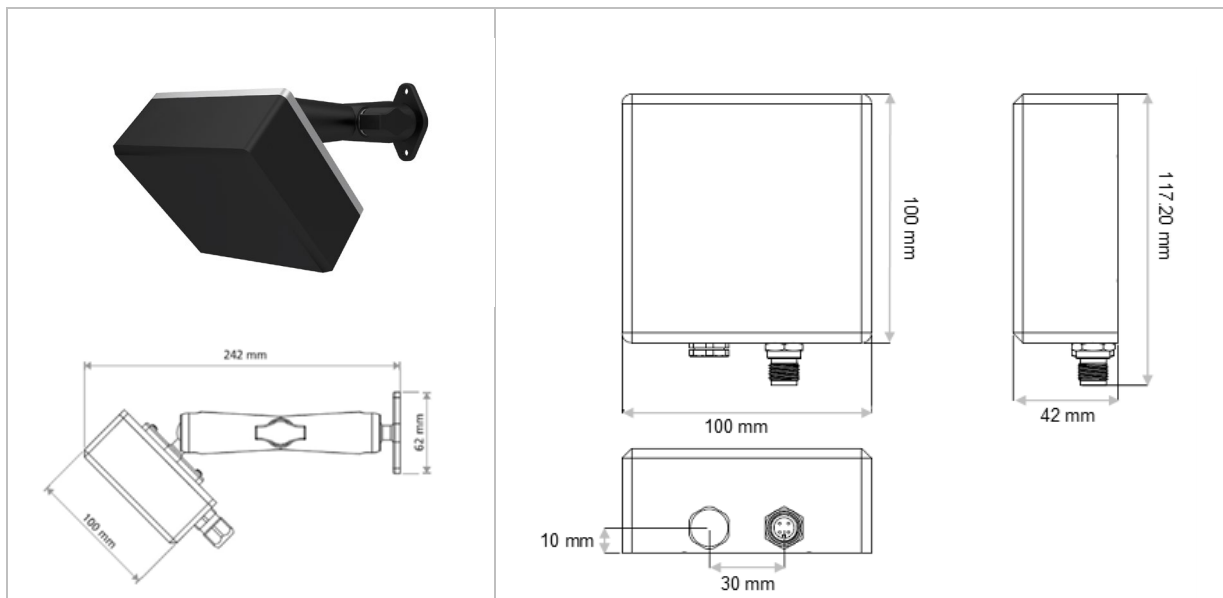

Figure 4: Radar velocity sensor type RV11 and dimensions [mm]

3.4.3.2 Non-contact radar velocity sensor RV24

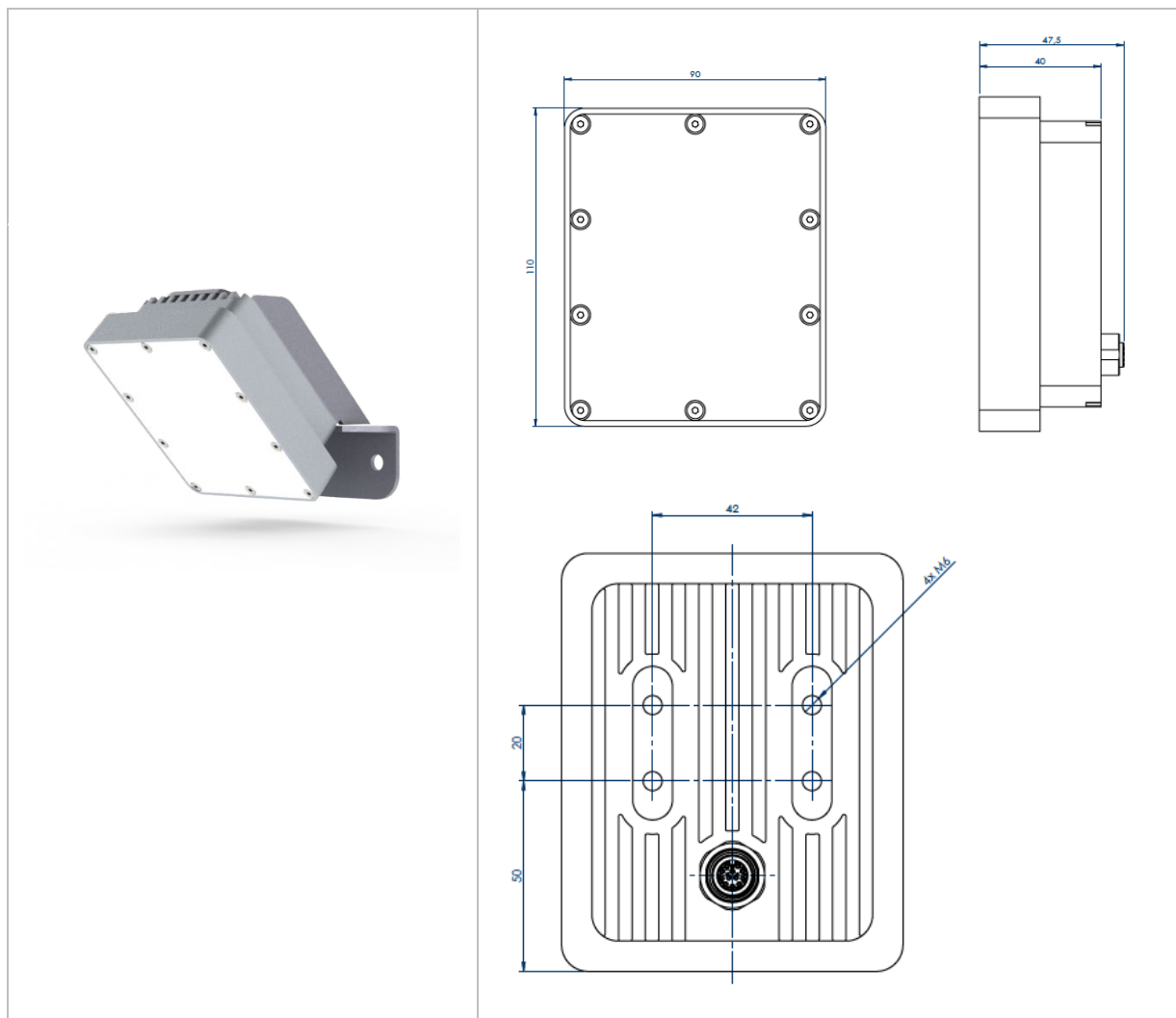

Figure 5: Radar velocity sensor type RV24 and dimensions [mm]

3.4.3.3 Non-contact ultrasonic or radar water level sensor

According to the installation height and site conditions different water level sensor types are available (see chapter 10.4 for detailed technical specifications).

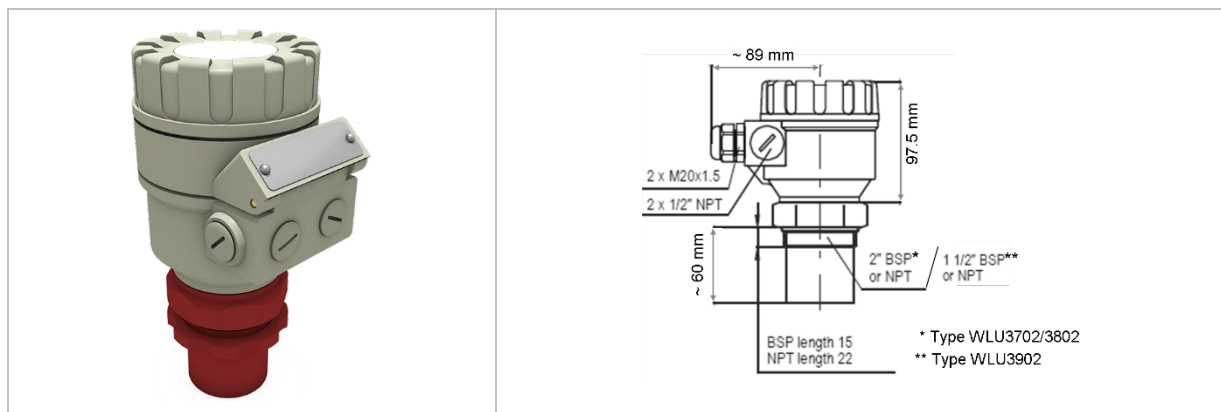

Figure 6: Non-contact ultrasonic water level sensor and sensor dimensions

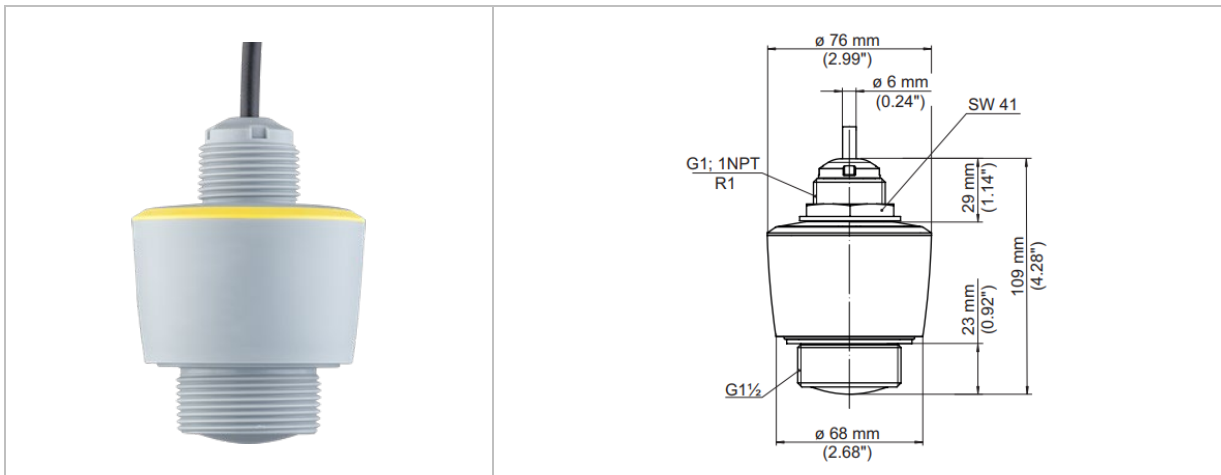

Figure 7: Non-contact radar water level sensor WLR1108 and sensor dimensions

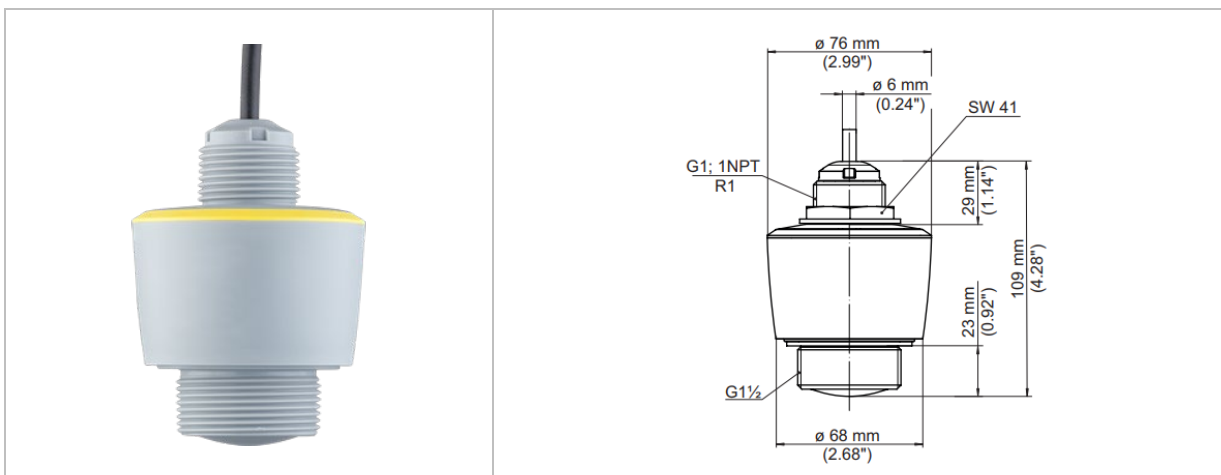

Figure 8: Non-contact radar water level sensor WLR2115 and dimensions

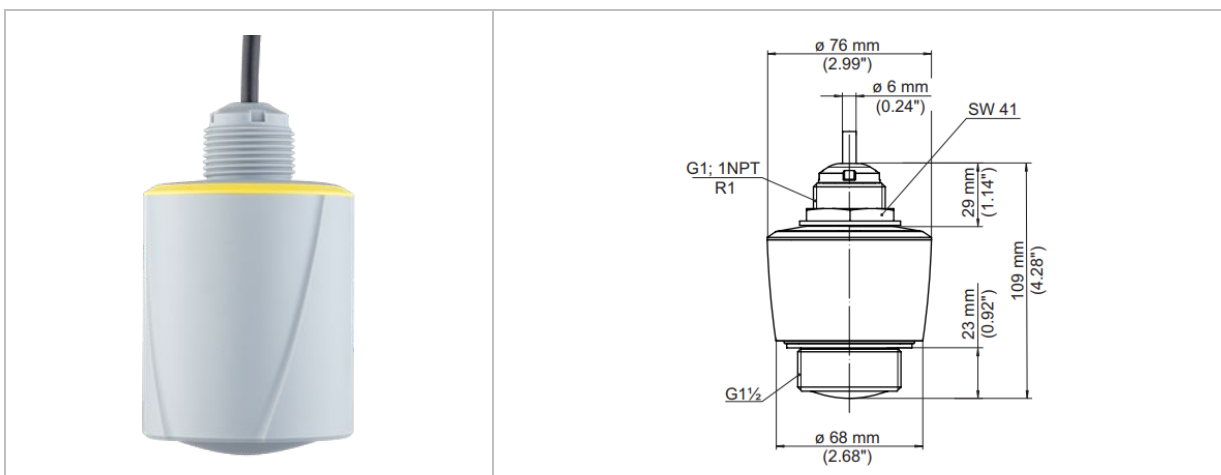

Figure 9: Non-contact radar water level sensor WLR2330 and dimensions

4. INSTALLATION

NOTICE!

Be advised that possible mounting and connection errors and their effects are beyond our control. Therefore, the manufacturer cannot be held responsible for damages because of incorrect handling, installation, and maintenance of the equipment.

4.1 Mounting of the transmitter

INFORMATION!

To avoid excessive sunlight exposure, the transmitter should be mounted in a position which is protected against direct sunlight. Make also sure that the device is sufficiently protected against rainfall.

- Select a proper position on a flat wall surface. Make sure to have a sufficient power supply in the vicinity of the transmitter. Also ensure a safe cabling.
- Mark the upper drill hole at the positions of the upper hanger in the middle on top of the transmitter enclosure.
- Drill hole for corresponding wall plug for fixing screw at the marked point.
- Mount the transmitter with fixing screw on the wall. Use suitable screws and plugs depending on the wall construction and installation conditions. Make sure the enclosure is aligned horizontally.
- Then mark the holes for the last two drillings on the left and right site on the bottom of the enclosure and follow the procedure described above.
- Be sure to tighten the screws firmly.

Temperature strip

For monitoring of higher ambient temperatures from 40°C and higher you will find a yellow self-adhesive temperature strip inside the transmitter enclosure. An increase to a certain temperature in the range of 40°C to 71°C will cause an irreversible change of colour of the specific segment from light grey to dark grey. The dark colour will remain even after subsequently cooling indicating the maximum temperature that has been reached.

Indicated temperature segments: 40°C, 43°C, 46°C, 49°C, 54°C, 60°C, 66°C, 71°C.

INFORMATION!

Always check temperature strip when opening the enclosure.

Please note that the temperature strip ensures quality assurance and therefore the review of warranty demands. Removal of the strip invalidates the warranty.

4.2 Mounting of the sensors

CAUTION

SENSORS IN USE MUST BE PROTECTED FROM MECHANICAL DAMAGE DUE TO IMPACTS OR ABRASION (E.G. FROM COARSE SEDIMENT LOAD OR ABRASIVE SEDIMENT MATERIAL).

Special mounting systems are available to make sensor installation easier and reduce installation time. The signal cable is already fixed at the sensor. The cable length needs to be adapted to site conditions and can be defined upon ordering. Always make sure that sensor cables connected to the transmitter are mounted firmly to the wall as tripping on the cables can cause both serious personal injury and permanent damage to cables and connectors. Check again, that the measuring window is not affected by the cables.

CAUTION

ANY ADJUSTMENTS OF CABLE LENGTHS MUST BE CARRIED OUT SOLELY BY THE MANUFACTURER. PLEASE CONTACT OUR SERVICE TECHNICIANS (INDUSTRIAL@BADGERMETER.COM).

To ensure reliable and accurate measurements make sure to observe the following mounting instructions for non-contact sensors:

Measuring site

- Select a suitable measuring site, ideally with an undisturbed, stable flow profile not influenced by turbulent currents (e.g. long straight channels or pipes).
- A straight inlet section of 10x the channel/pipe width upstream of the sensor and 3x the channel width downstream of the sensor is recommended.
- Stationary waves caused by obstacles in the riverbed (e.g. pillars, big stones) must be avoided because they might disrupt the flow profile. Also avoid backflow caused by weirs or gates.
- The minimum wave height must be 3mm for the RV11 and 1 mm for the RV24. This ensures sufficient surface roughness to measure a reliable Doppler frequency.
- Select a measurement location that will not dry to guarantee continuous measurement. The recommended value for minimum water level is 10 cm.
- Choose a suitable mounting height such that the radar sensor will not be submerged, even under high water conditions.
- Be careful not to select the measuring point directly at a widening of the cross-section into a reservoir or basin.
- When using a down-looking water level sensor, select a location with a slope of $< 3^\circ$.

Installation at site

- It is recommended to install the radar sensor against the flow direction. However, the sensor can measure flow velocity bi-directionally.
- The radar sensor can be installed either on bridges, extension arms or cable ways. Ensure a stable installation to avoid vibrations of the sensor.
- Protect the sensor from wind wherever possible.
- Installation directly on or next to bridge piers is not recommended due to possible backflow conditions and flow disturbances due to the pillars.
- Keep in mind that unwanted reflections from rough ceilings (e.g. under bridges, pipes) might influence the received reflections of the sensor and therefore the accuracy of the measurement.
- It is recommended to install the radar sensor against the flow direction. However, the sensor measures flow velocity independent of the flow direction. The sensor position according to the flow direction must be defined.
- The maximum mounting height of the radar velocity sensor above the water surface is 10 m for the RV11 and 20 m for the RV24.
- The minimum distance to the surface of the water in the direction of transmission is 0.2 m for the RV11 and 0.5 m for the RV24.
- Since the radar sensor type RV11 does not have an integrated inclination measurement, the installation angle must be specified for correction of the velocity measurement. The RV24 automatically records the installation angle.
- The mounting angle should be between 20° and 60° , the recommended value is 30°
- Ensure that the sensor field of view is free from any moving objects, e.g. from vegetation moving in the wind.
- The size of the measuring area of the water surface detected by the radar sensor depends on the opening angle, the inclination angle and the installation height (see chapter 9.2).
- The measuring beam of the radar velocity sensor must be entirely on the water surface such that no disturbing reflections occur.

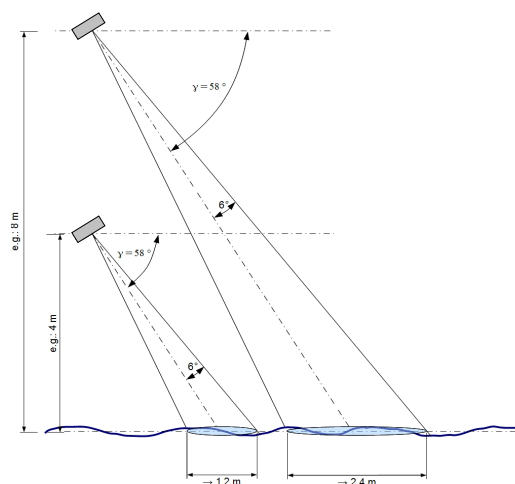

Figure 10: Size of measuring spot area of the radar velocity sensor according to installation height (example installation in 4 m and in 8 m, radar opening angle: 12° , inclination angle $\gamma = 58^\circ$)

- When installing the non-contact water level sensor, make sure that the beam cone of the sensor hits the water surface unhindered at a right angle. Ideally, the measuring ranges of the velocity sensor and the water level sensor should hit the water surface at approximately the same point (see Fig. 11)

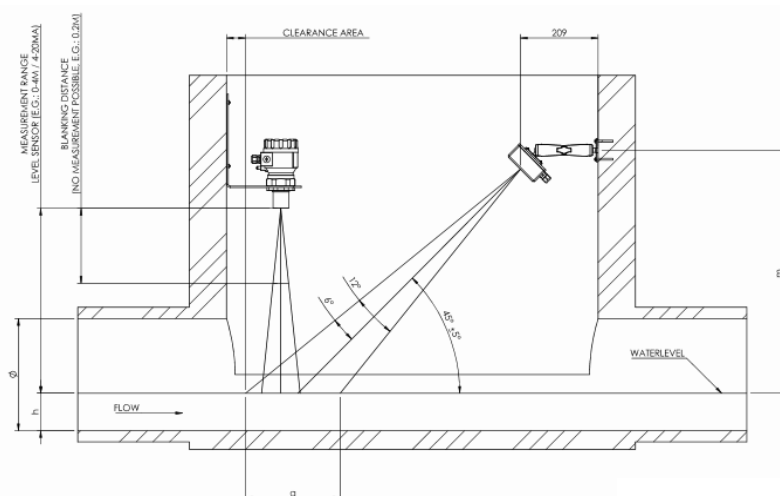

Figure 11: Example for an installation of radar velocity sensor (radar opening angle: 12° , inclination angle $\chi = 45^\circ$) and water level sensor in a manhole

4.3 Calibration

For all flow velocity measuring systems for partially filled cross sections which are installed in existing pipelines a calibration of the measuring site (measurement of network, tracer measurement etc.) is recommended in order to receive optimum measuring accuracy. During calibration the water level at the measuring site should be at least 10 cm.

(INSTRUCTIONS FOR CALIBRATION OF MEASURING SITES SEE DIN EN ISO 748 [2]).

INFORMATION!

Calculation for calibration is performed via software in the calibration menu of user interface (► Parameter ▷ Calibration).

5. ELECTRICAL CONNECTION

WARNING

- **IMPROPER CONNECTION CAN CAUSE INJURY OR DEATH. THE ELECTRICAL CONNECTION MUST BE CARRIED OUT BY A CERTIFIED ELECTRICIAN.**
- **OBSERVE THE NATIONAL REGULATIONS FOR ELECTRICAL INSTALLATIONS! BY HANDLING PRODUCTS, WHICH ARE SUPPLIED BY ELECTRICAL VOLTAGE, THE VALID IEC INSTRUCTIONS, ESPECIALLY IEC 60364, IEC 61558, IEC 60335, IEC 60598-1 AND IEC 60065 MUST BE OBSERVED.**
- **BEFORE OPENING AN INSTRUMENT, PULL OFF THE MAIN PLUG AND MAKE SURE THAT THE INSTRUMENT IS WITHOUT POWER SUPPLY. PARTS, CONSTRUCTION GROUPS OR INSTRUMENTS MUST ONLY BE SET INTO OPERATION IN CASE THEY ARE BUILT INTO A HOUSING AND PROTECTED AGAINST TOUCHING. DURING INSTALLATION THEY MUST BE WITHOUT POWER. IT IS ONLY ALLOWED TO USE TOOLS AT THE INSTRUMENTS, PARTS OR CONSTRUCTION GROUPS IF IT HAS BEEN ENSURED THAT THE DEVICES ARE DISCONNECTED FROM THE SUPPLY VOLTAGE AND THE ELECTRIC LOADS WHICH ARE STORED IN THE CONSTRUCTION GROUPS INSIDE THE INSTRUMENT ARE UNLOADED. CONDUCTING CABLES OR CONDUCTORS WHICH ARE CONNECTED TO THE INSTRUMENT, PART OR CONSTRUCTION GROUP, MUST BE CHECKED CONTINUOUSLY FOR ISOLATION FAULTS OR SITES OF FRACTURES. IF A FAULT IS FOUND IN THE SUPPLY LINE, THE INSTRUMENT MUST BE SWITCHED OFF IMMEDIATELY TILL THE DEFECTIVE LINE HAS BEEN REPLACED.**
- **BY USING CONSTRUCTION ELEMENTS OR GROUPS PLEASE MAKE SURE THAT THE FEATURES FOR ELECTRICAL SIZES ARE OBSERVED ACCORDING TO THE RESPECTIVE DESCRIPTION. IN CASE IT IS NOT POSSIBLE TO CLARIFY CLEARLY FOR A NON-COMMERCIAL END-USER WHICH ELECTRICAL VARIABLES ARE VALID FOR A PART OR A CONSTRUCTION GROUP, HOW EXTERNAL WIRING IS TO BE UNDERTAKEN, WHICH EXTERNAL COMPONENTS OR ADDITIONAL DEVICES CAN BE CONNECTED AND WHICH CONNECTION VALUES THESE EXTERNAL COMPONENTS MAY HAVE, ALWAYS CONTACT AN EXPERT FOR RESPECTIVE INFORMATION.**
- **BEFORE SETTING INTO OPERATION GENERALLY CHECK IF THE INSTRUMENT OR CONSTRUCTION GROUP IS SUITABLE FOR THE FIELD OF APPLICATION. IF THERE IS ANY DOUBT, YOU MUST INQUIRE WITH A TECHNICAL EXPERT OR THE MANUFACTURER OF THE USED CONSTRUCTION GROUP.**
- **COMPARE SPECIFICATIONS ON THE NAMEPLATE AND CHECK FOR THE CORRECT SUPPLY VOLTAGE ON THE NAMEPLATE.**
- **FEED THE POWER SUPPLY CABLE AND SIGNAL CABLES THROUGH THE APPROPRIATE CABLE ENTRIES.**

RISK OF ELECTRIC SHOCK! SWITCH OFF POWER SUPPLY BEFORE OPENING THE DEVICE. DO NOT INSTALL OR WIRE THE DEVICE WHILE IT IS CONNECTED TO THE POWER SUPPLY. DISREGARDING COMPLIANCE WITH THIS PRECAUTION MAY RESULT IN IRREPARABLE DAMAGE TO THE ELECTRONICS.

NOTICE:

- **Protective grounding:** Suitable measures for error protection must be carried out. The conductive system parts to be protected must be connected to a suitable earthing conductor via the PE conductor, so that the system parts with a fault are switched off by overcurrent protection devices
- **Electronic Discharge:** Electronic components can be destroyed by electrostatic discharge during in-stallation. Avoid high electrostatic charges by using suitable grounding measures.
- **Disconnecting device:** The device must be connected and disconnected to the mains by means of a disconnecting device.
- **Power / connection cable:** Upon delivery, the transmitter power cable is already connected. If necessary, use a strain relief for the connected cable to prevent accidental disconnection.
- The system has no on / off switch. It is therefore imperative to attach the system to an additional circuit breaker (at least 2A) to disconnect the system from the power supply in the event of a fault or repair. The circuit breaker should be within easy reach.
- It is necessary to connect the system to an external overvoltage protection device (for example, a circuit breaker).

5.1 Terminal compartment

The terminal configurations have been set by the manufacturer depending on the specifications ordered. For individual wiring of additional components please refer to pin assignments described in the following chapters. To open the terminal compartment, unscrew the enclosure cover.

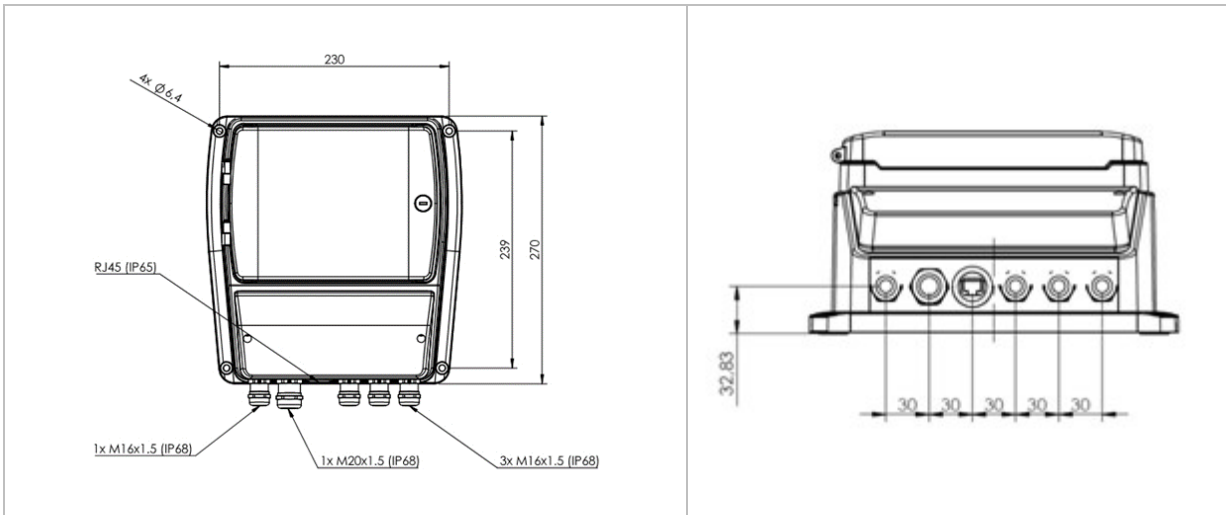

Figure 12: Overview transmitter without integrated 4G modem

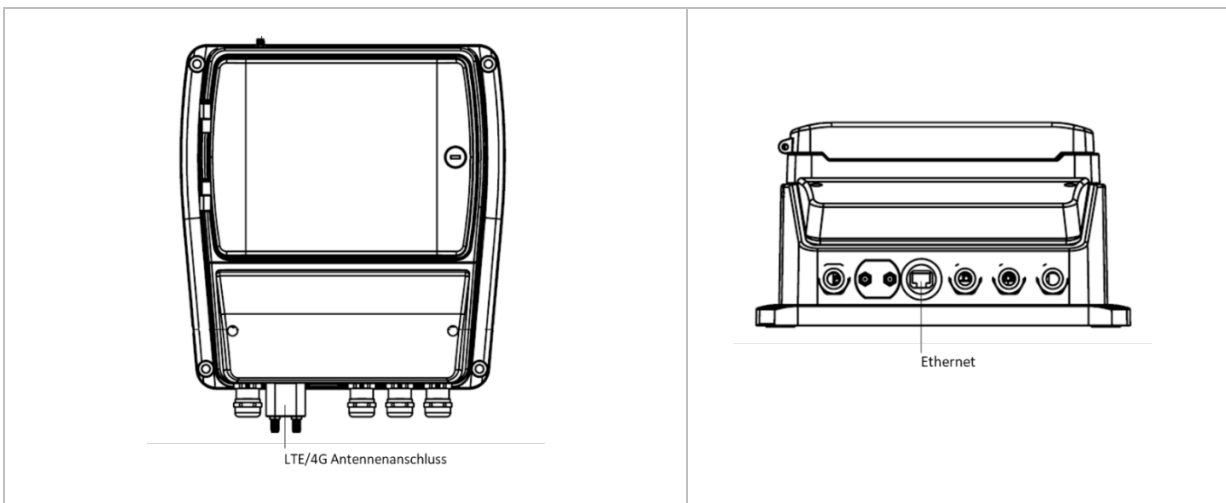

Figure 13: Overview transmitter with integrated 4G modem

INFORMATION!

The 4G/LTE dipole antenna is connected via the antenna connector on the enclosure bottom next to the cable entry blocks.

NOTICE!

- Specification for cables for wiring:
- use copper cable only
- temperature: min. 70°C
- cable diameter: 1mm²

5.2 Pin assignment

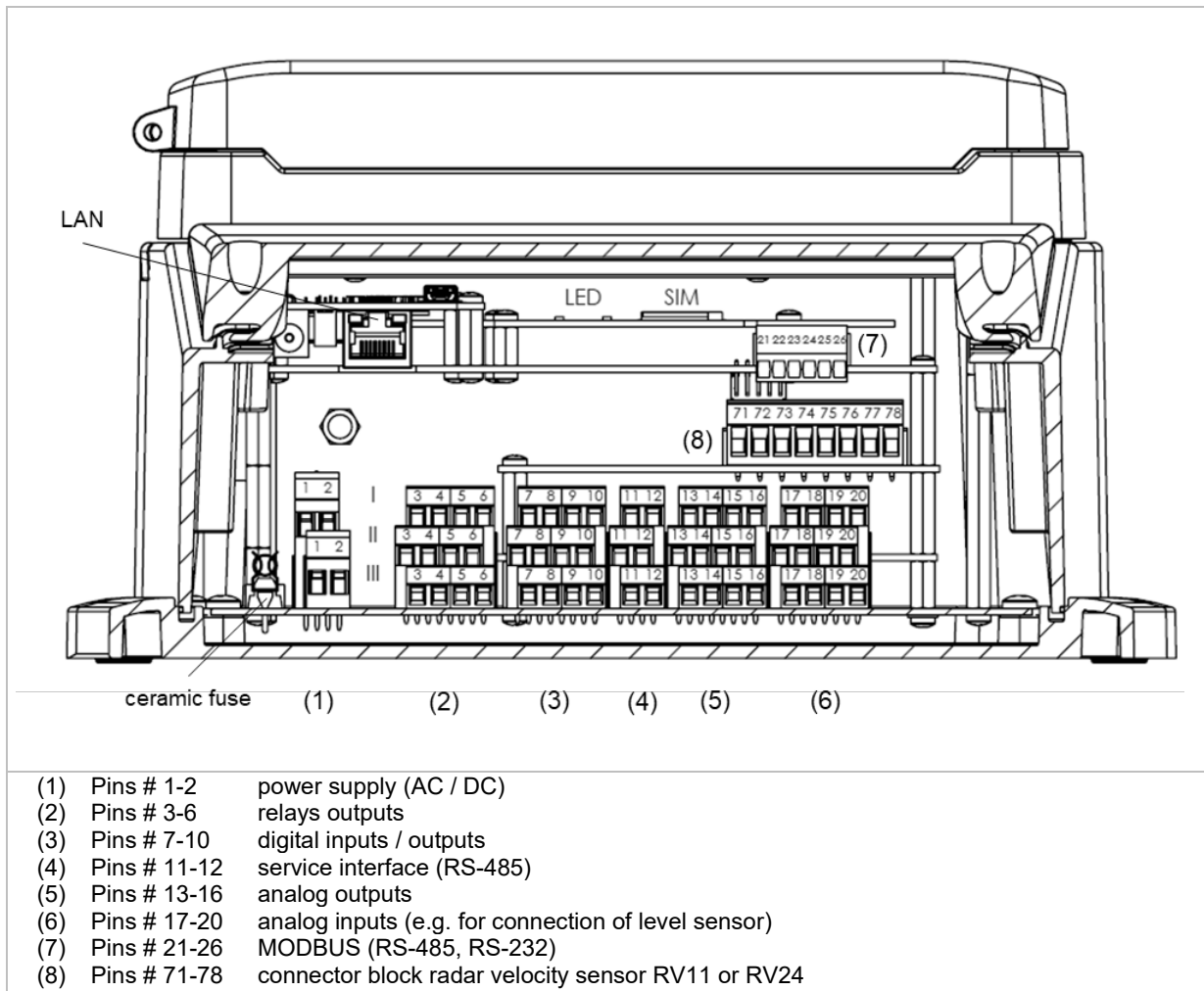

Figure 14: Overview connections Radar

Pin assignment Radar				
Block	Row / No.	Name	Description	Cable colour
(1) AC Power Supply (100-240 VAC)	(I) (1)	L Phase*	power supply	brown or black
	(II) (1)	PE	protective earth; grounding terminal	green/yellow
	(I) (2)	N Neutral*	power supply	blue
	(II) (2)	PE	protective earth; grounding terminal	green/ yellow
(1) DC Power Supply (9-36 VDC)	(I) (1)	+ DC In	power supply	red
	(II) (1)	PE	protective earth; grounding terminal	green/yellow
	(I) (2)	- DC In	power supply	black
	(II) (2)	PE	protective earth; grounding terminal	green/yellow

* L = external conductor, N = neutral conductor

(2) AC/DC Relay Outputs	(I) (3)	NO1	Relay 1
	(II) (3)	COM1	normally closed (NC) or normally open (NO) contact available
	(III) (3)	NC1	max. 40 V / 1A AC, max. 60 V / 1A DC
	(I) (4)	NO2	Relay 2
	(II) (4)	COM2	normally closed (NC) or normally open (NO) contact available
	(III) (4)	NC2	max. 40 V / 1A AC, max. 60 V / 1A DC
	(I) (5)	NO3	Relay 3
	(II) (5)	COM3	normally closed (NC) or normally open (NO) contact available
	(III) (5)	NC3	max. 40 V / 1A AC, max. 60 V / 1A DC
	(I) (6)	NO4	Relay 4
	(II) (6)	COM4	normally closed (NC) or normally open (NO) contact available
(III) (6)	NC4	max. 40 V / 1A AC, max. 60 V / 1A DC	
(3) AC/DC Digital Inputs / Outputs	(I) (7)	+DO1	pulse output 1 (+) pulse width / frequency adjustable
	(II) (7)	- DO1	pulse output 1 (-)
	(III) (7)	+24VDC*	
	(I) (8)	+DO2	pulse output 2 (+) pulse width / frequency adjustable
	(II) (8)	- DO2	pulse output 2 (-)
	(III) (8)	GND	
	(I) (9)	+DI1	digital input 1 (+) max. 30 V
	(II) (9)	- DI1	digital input 1 (-)
	(III) (9)	+24VDC*	
	(I) (10)	+DI2	digital input 2 (+) max. 30 V
(II) (10)	- DI2	digital input 2 (-)	
(III) (10)	GND		
(4) AC/DC Service Interface RS-485	(I) (11)	A	not connected
	(II) (11)	B	not connected
	(III) (11)	Y	not connected
	(I) (12)	Z	not connected
	(II) (12)		not connected
	(III) (12)		not connected

Pin assignment Q-Eye Radar			
Block	Row / No.	Name	Description
(5) AC/DC Analog Outputs	(I) (13)	+AO1	analog output 1 (+) active, 4-20 mA, load < 550 Ω
	(II) (13)	-AO1	analog output 1 (-)
	(III) (13)	+24VDC*	
	(I) (14)	+AO2	analog output 2 (+) active, 4-20 mA, load < 550 Ω
	(II) (14)	-AO2	analog output 2 (-) 0/4 to 20 mA
	(III) (14)	GND	
	(I) (15)	+AO3	analog output 3 (+) active, 4-20 mA, load < 550 Ω
	(II) (15)	-AO3	analog output 3 (-) 0/4 to 20 mA
	(III) (15)	+24VDC*	
	(I) (16)	+AO4	analog output 4 (+) active, 4-20 mA, load < 550 Ω
	(II) (16)	-AO4	analog output 4 (-) active, 4-20 mA, load < 550 Ω
	(III) (16)	GND	
(6) AC/DC Analog Inputs	(I) (17)	+AI1	analog input 1(+) 4-20 mA
	(II) (17)	-A1	analog input 1(-)
	(III) (17)	+24VDC*	
	(I) (18)	+AI2	analog input 2 (+) 4-20 mA
	(II) (18)	-AI2	analog input 2 (-)
	(III) (18)	GND	
	(I) (19)	+AI3	analog input 3 (+) 4-20 mA
	(II) (19)	-AI3	analog input 3 (-)
	(III) (19)	+24VDC*	
	(I) (20)	+AI4	analog input 4 (+) 4-20 mA
	(II) (20)	-AI4	analog input 4 (-)
	(III) (20)	GND	

* max. 200 mA = auxiliary supply (sum) for all connected sensors

(7) AC/DC MODBUS	RS-485		RS-232
	4-wire	2-wire	
(21)	-TX	-D	TXD
(22)	+TX	+D	NA
(23)	-RX	NA	NA
(24)	+RX	NA	RXD
(25)	GND	GND	GND
(26)	SH	SH	SH

Pin assignment Radar			
Block	Row / No.	Name	Cable colour
(8) RV11 Radar velocity sensor connection	(71)	RS-485 A	green/yellow
	(72)	RS-485 B	white/brown
	(73)	RS-485 Y	not connected
	(74)	RS-485 Z	not connected
	(75)	shield	metallic braided shield
	(76)	V + (velocity sensor)	red/pink/grey
	(77)	GND (velocity sensor)	black/purple/blue
	(78)	SYSGND	not connected
(8) RV24 Radar velocity sensor connection	(71)	RS-485 A	not connected
	(72)	RS-485 B	not connected
	(73)	RS-485, D-, sender/receiver „high“ signal	dark red
	(74)	RS-485, D+, sender/receiver „low“ signal	orange
	(75)	shield	not connected
	(76)	V _{in} + (velocity sensor)	brown
	(77)	GND (velocity sensor)	white
	(78)	SYSGND	not connected

INFORMATION!

Input/output data (I/O values) are programmed in the software in the ► I/O main menu.

Additional elements

SIM card slot	Slot for SIM card insertion / removal
LAN	RJ45 socket for Ethernet connection / local LAN via RJ45 cable
LED	LED control light flashes during GSM data transfer
Fuse	AC version: Fuse T2A (slow blow fuse) / 250V 5x20 DC version: Fuse T3,15 A (slow blow fuse) / 250V 5x20

5.3 Connection to external 3G/2G router

The RJ45 socket with Ethernet cable is used for the connection to an external 3G/2G router. Note that for the AC transmitter version an additional AC power supply adapter is required.

INFORMATION!

An additional router configuration manual will be provided to ensure correct connection.

5.4 Connection of sensors

Sensors are connected to the connector blocks according to the specific sensor types. The voltage supply of the sensors is provided by the transmitter.



- **BEFORE CONNECTING OR DISCONNECTING THE CABLE, BE SURE THE POWER IS SWITCHED OFF.**
- **SENSOR CONNECTION MUST BE CARRIED OUT IN ACCORDANCE TO WIRING DIAGRAM, I.E. THE CABLE COLOURS MUST MATCH WITH PIN ASSIGNMENT.**
- **FOR CONNECTING THE CABLE SHEATH SHOULD ONLY BE REMOVED FOR A MAXIMUM LENGTH OF 4 CM.**
- **THE STRIPPED LENGTH OF THE INNER CONDUCTOR HAS TO BE SHORTER THAN 7 MM.**
- **STRANDED ENDS SHOULD BE EITHER PROVIDED WITH FERRULES OR TINNED.**
- **AVOID TOO TIGHT CLAMPING WHEN ATTACHING THE CABLE TO THE TRANSMITTER. COMPRESSION OF THE CONVERTER CABLE MIGHT LEAD TO SHORT-CIRCUIT BETWEEN THE SIGNAL AND THE SHIELDING AND MIGHT DAMAGE THE TRANSMITTER.**
- **AFTER CONNECTING THE CABLE, THE CABLE BUSHING UNDERNEATH THE HOUSING SHOULD BE TIGHTENED.**
- **ALL CABLES MUST BE INSTALLED IN ORDER TO PROTECT CABLES FROM MECHANICAL DESTRUCTION. MOUNT THE CABLES FIRMLY TO THE WALL, WITHOUT ANY LOOPS AND CROSS-OVERS AND IN SUFFICIENT DISTANCE TO MOVING PARTS TO AVOID ACCIDENTS CAUSED BY STUMBLING.**

5.4.1 CONNECTION OF RADAR VELOCITY SENSOR RV11

	No.	Name / Description	Cable colour
	(71) A	RS-485 A	green/yellow
	(72) B	RS-485 B	white/brown
	(73) Y	RS-485 Y	not used
	(74) Z	RS-485 Z	not used
	(75) S	Shield	metallic braided shield
	(76) +	V + (velocity sensor)	red/pink/grey
	(77) -	GND (velocity sensor)	black/purple/blue
	(78)	SYSGND	not used

Figure 15: Pin assignments for the connection of radar velocity sensor type RV11

5.4.2 CONNECTION OF RADAR VELOCITY SENSOR RV2411

	No.	Name / Description	Cable colour
	(71) A	RS-485 A	not used
	(72) B	RS-485 B	not used
	(73) Y	RS-485, D-, sender/receiver „high“ signal	dark red
	(74) Z	RS-485, D+, sender/receiver „low“ signal	orange
	(75) S	shield	not used
	(76) +	V _{in} + (velocity sensor)	brown
	(77) -	GND (velocity sensor)	white
	(78)	SYSGND	not used

Figure 16: Pin assignments for the connection of radar velocity sensor type RV24

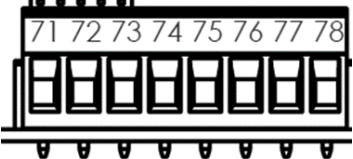
5.4.3 CONNECTION OF EXTERNAL LEVEL SENSORS ON ANALOG INPUT BLOCK

An additional external level sensor (hydrostatic level sensor, ultrasonic or radar down-looking level sensor) can be connected on the analog input block (block no. 6). Depending on the sensor type, different wiring types (2-wire loop, 3-wir loop or 4-wire loop) are possible for connection.

Sensor connection must be carried out in accordance to wiring diagrams (Fig. 17, Fig. 18, Fig. 19).

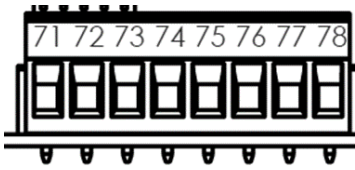
External water level sensors that can be purchased from Badger Meter:

- Type WLU*: Open channel ultrasonic down-looking level sensors. 2-wire connection.
- Type WLR*: Open channel radar down-looking level sensors. 2-wire connection.
- Type WLP36*: Submerged hydrostatic pressure sensor, 2-wire connection.
- Type WLP54: Insertion hydrostatic pressure sensor for closed pipes, 2-wire connection.
- Type CSA: Ultrasonic down-looking level sensor for closed pipes, 3-wire connection.

5.4.3.1 2-wire loop



	No. (Row) (No.)	Name	Description	Cable colour
	(I) (17)	+AI1	Sensor - h - Signal -	Manuf.-Specific
	(II) (17)	- AI1	Bridge (III)(18)	black
	(III) (17)	+24V DC	Sensor - h - Signal +	Manuf.-Specific
	(I) (18)	+AI2	Analog input 2 (+) 4-20 mA	
	(II) (18)	-AI2	Analog input 2 (-)	
	(III) (18)	GND	Bridge (II)(17)	black
	(I) (19)	+AI3	Analog input 3 (+) 4-20 mA	
	(II) (19)	-AI3	Analog input 3 (-)	
	(III) (19)	+24V DC		
	(I) (20)	+AI4	Analog input 4 (+) 4-20 mA	
	(II) (20)	-AI4	Analog input 4 (-)	
	(III) (20)	GND		

Figure 17: Analog input block - pin assignments 2-wire loop

Type WLU* (Down-looking ultrasonic, open channels):

	No. (row) (no.)	Name	Description	Cable colour
	(I) (17)	+AI1	sensor-h – signal -	green/yellow
	(II) (17)	- AI1	bridge (III) (18)	Choose any Standard: black
	(III) (17)	+24V _{DC}	sensor-h – signal +	white/brown
	(I) (18)	+AI2	analog input 2 (+) 4-20 mA	
	(II) (18)	-AI2	analog input 2 (-)	
	(III) (18)	GND	bridge (II)(17)	Choose any Standard: black

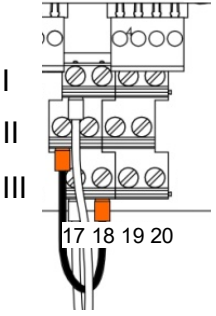
Type WLR* (Down-looking radar, open channels):

	No. (row) (no.)	Name	Description	Cable colour
	(I) (17)	+AI1	sensor-h – signal -	blue
	(II) (17)	- AI1	bridge (III) (18)	Choose any Standard: black
	(III) (17)	+24V _{DC}	sensor-h – signal +	brown
	(I) (18)	+AI2	analog input 2 (+) 4-20 mA	
	(II) (18)	-AI2	analog input 2 (-)	
	(III) (18)	GND	bridge (II)(17)	Choose any Standard: black

Type WLP36* (Submerged hydrostatic pressure):

	No. (row) (no.)	Name	Description	Cable colour
	(I) (17)	+AI1	sensor-h – signal -	white
	(II) (17)	- AI1	bridge (III) (18)	Choose any Standard: black
	(III) (17)	+24V _{DC}	sensor-h – signal +	black
	(I) (18)	+AI2	analog input 2 (+) 4-20 mA	
	(II) (18)	-AI2	analog input 2 (-)	
	(III) (18)	GND	bridge (II)(17)	Choose any Standard: black

Type WLP54 (Insertion hydrostatic pressure, closed pipes):

	No. (row) (no.)	Name	Description	Cable colour
	(I) (17)	+AI1	sensor-h – signal -	black
	(II) (17)	- AI1	bridge (III) (18)	Choose any Standard: black
	(III) (17)	+24V _{DC}	sensor-h – signal +	red
	(I) (18)	+AI2	analog input 2 (+) 4-20 m A	
	(II) (18)	-AI2	analog input 2 (-)	
	(III) (18)	GND	bridge (II)(17)	Choose any Standard: black

5.4.3.2 3-wire loop

	No. (Row) (No.)	Name	Description	Cable colour
	(I) (17)	+AI1	Sensor - h - Signal +	Manuf.-Specific
(II) (17)	- AI1	Bridge (III)(18)	Manuf.-Specific	
(III) (17)	+24V DC	Sensor - h - + 24V DC	Manuf.-Specific	
(I) (18)	+AI2	Analog input 2 (+) 4-20 mA		
(II) (18)	-AI2	Analog input 2 (-)		
(III) (18)	GND	Sensor - h - GND; Bridge (II)(17)	Manuf.-Specific	
(I) (19)	+AI3	Analog input 3 (+) 4-20 mA		
(II) (19)	-AI3	Analog input 3 (-)		
(III) (19)	+24V DC			
(I) (20)	+AI4	Analog input 4 (+) 4-20 mA		
(II) (20)	-AI4	Analog input 4 (-)		
(III) (20)	GND			

Figure 18: Analog input block - pin assignments 3-wire loop

5.4.3.3 4-wire loop

	Nr. (Row) (No.)	Name	Description	Cable colour
	(I) (17)	AI1+	Sensor - h - Signal +	Manuf.-Specific
(II) (17)	AI1-	Sensor - h - Signal -	Manuf.-Specific	
(III) (17)	+24V DC	Sensor - h - + 24V DC	Manuf.-Specific	
(I) (18)	+AI2	Analog input 2 (+) 4-20 mA		
(II) (18)	-AI2	Analog input 2 (-)		
(III) (18)	GND	Sensor - h - GND	Manuf.-Specific	
(I) (19)	+AI3	Analog input 3 (+) 4-20 mA		
(II) (19)	-AI3	Analog input 3 (-)		
(III) (19)	+24V DC			
(I) (20)	+AI4	Analog input 4 (+) 4-20 mA		
(II) (20)	-AI4	Analog input 4 (-)		
(III) (20)	GND			

Figure 19: Analog input block - pin assignments 4-wire loop

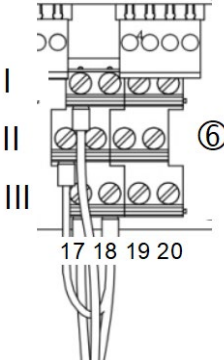
RS-485 /RS-232 MODBUS CONFIGURATION

INFORMATION!

The 120-Ohm termination resistor is only needed for the last participant / device on the bus.

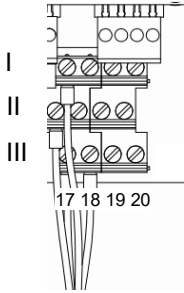
Upon delivery, the dip switch settings at the MODBUS module are set to RS-485 4-wire (standard setting). For RS-485 2-wire, the dip switches are 1 OFF, 2 OFF, 3 ON, 4 ON. For other specific settings please contact our service engineers.

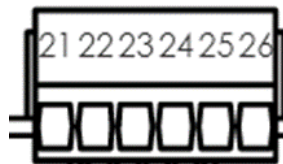

Figure 20: Pin assignments for connection to RS-485 2-wire / 4-wire and RS-232

		No.	Name / Description		
(7)	AC/DC MODBUS RS-485 / RS-232		RS-485 4-wire (standard)	RS-485 2-wire	RS-232
		(21)	-TX	-D	TXD
		(22)	+TX	+D	NA
		(23)	-RX	NA	NA
		(24)	+RX	NA	RXD
		(25)	GND	GND	GND
		(26)	SH	SH	SH

NA: not assigned/used

5.5 Final check of electrical connections

On completion of the electrical wiring and before connecting the device to the power supply ensure again that the supply voltage matches the specification on the name plate and check the following instructions:

NOTICE!

- Visual inspection for damages on transmitter, cables, sensors and cables glands.
- Ensure the enclosure is properly fitted, clean and undamaged. All screws must be firmly tightened.
- All cable glands must be installed, tightened, and sealed.
- Use blind plugs for unused cable entries.
- Lay the cables in a downward hanging loop just before the cable entry so that possible moisture can collect in the loop and do not reach the cable entry.
- Adjustment of cables must be carried out by the manufacturer only.
- Mounted cables must have adequate strain relief.
- Do not bend cables to avoid cable breaks.
- Defect cables must be replaced by the manufacturer only.

INFORMATION!

For devices with external 3G/2G router or integrated 4G/3G/2G modem, it is recommended to insert the SIM card and connect the 4G/LTE dipole antenna **prior** to turning on the power supply.

6. COMMUNICATION WITH TRANSMITTER

6.1 Control panel and LC-Display

The transmitter does not have an extra power switch. On connecting the transmitter to a power supply the LC-Display shows the programmed parameters and the control panel can be operated (Fig. 21).

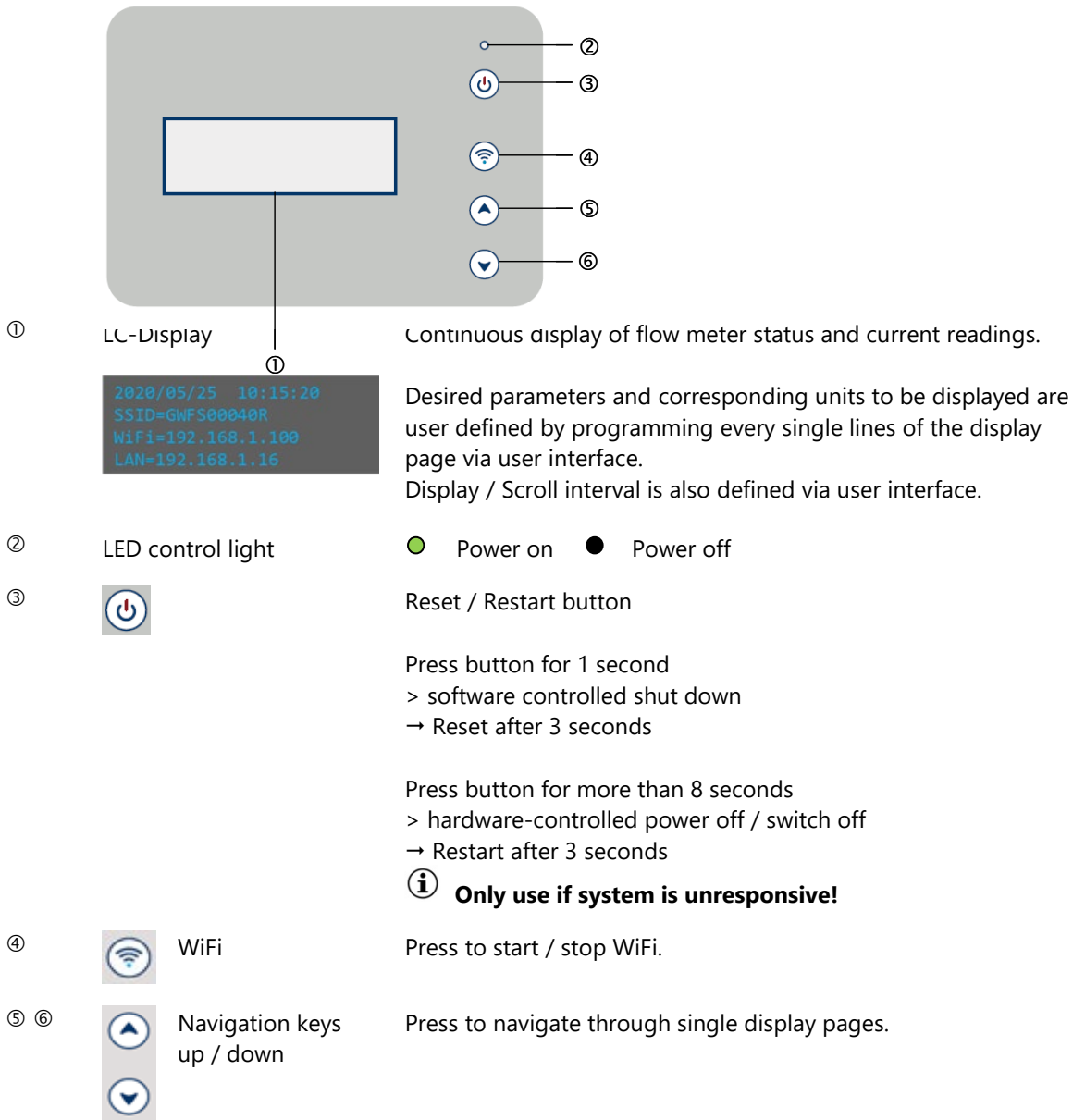

Figure 21:Control panel and display functions

For programming and operation simply connect your PC, notebook, tablet or smart phone to the flow computer of the transmitter via WiFi or LAN by calling up the graphic user interface (GUI) using a standard web browser.

6.2 Wireless communication WiFi

Follow the following steps to establish communication to transmitter (WiFi):

- (1) Switch on the power supply for the transmitter.
Wait a few seconds until system parameters are shown on the display.
The display will show the predefined specific SSID (access point name) of the device:
e.g. BadgerS00040R (corresponding to serial number of device).

- (2) Start WiFi by pressing WiFi button of transmitter.

Press 

Wait for status message "WiFi on!".



- (3) Switch on your PC, notebook, tablet or smartphone and establish WiFi connection according to your operating system.
- (4) Select predefined SSID to connect transmitter with your device.
Enter the **WiFi password** according to the purchase order number of the device ([see nameplate](#)).
Enter only numbers without characters or space!
Example:
Network number: Badger-131104/1208 > **password: 1311041208**
Then open your web browser and type the following IP address in the address bar:
192.168.1.100
The IP address is also displayed on the transmitter display under WiFi.
- (5) If your device is connected to the transmitter, the login page of the GUI (graphical user interface) opens.

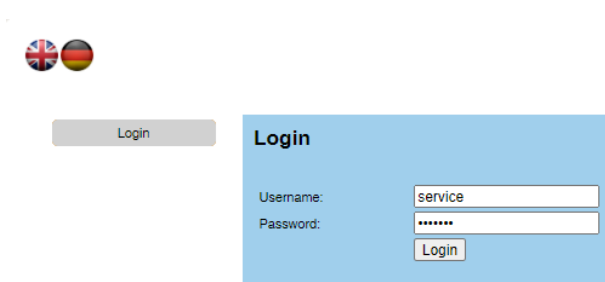

- (6) Log in by entering username and password to start working with the user interface.

Username: service

Password: badger6000



Cookies and JavaScript must be enabled in your browser settings to login.

If settings are not activated the following error messages appear:



The image shows a login interface with a light blue background. At the top, it says "Username:" followed by a text input field containing "service". Below that is "Password:" followed by an empty text input field. A "Login" button is positioned below the password field. Below the login fields, there are two red error messages: "Sorry, but cookies must be enabled !" and "Sorry, but Javascript is required !".

6.3 Communication to the transmitter via Ethernet LAN

Badger Meter transmitters are configured to use DHCP by default, so that an IP address will be automatically assigned if a DHCP server is in the same network.

If no DHCP server is available or a direct (point-to-point) connection with an RJ45 (Ethernet) network cable to a PC shall be established, the Badger Meter transmitters provide "automatic private IP addressing (APIPA)".

In this case, the user interface of the transmitter can be accessed with the Internet browser via the Internet address <http://Serialnumber.local/>. The transmitter must be connected directly to the PC or laptop using an RJ45 (Ethernet) network cable.

Example:

The transmitter with the serial number BadgerS00040R can be accessed via the following web address: <http://BadgerS00040R.local/>

Note:

The addressing is not case-sensitive.

After connecting the transmitter and the PC with an RJ45 network cable, it can take up to 2 minutes before a connection can be established.

Manual IP address assignment (without DHCP): If a static IP address, subnet mask and default gateway are required, the parameters can be assigned manually by deactivating DHCP and enter new IP address and network parameters.

The settings are changed in GUI in the main menu ► Communication under ▷ Network LAN ([see chapter 7.9.1.2](#)).

7. PROGRAMMING

7.1 Login

After connecting to the transmitter, the login page of the GUI will be displayed.

► Login

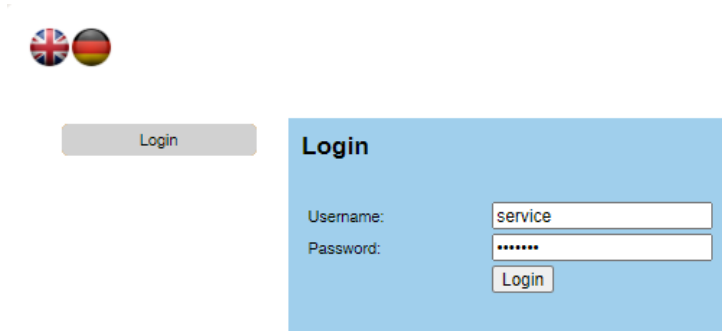

Einstellung	Description
Username	> Enter username > service
Password	> Enter your password > badger6000
	↪ Click Login to sign in.

A query window appears for saving the password for future logins (browser dependent).

Save password ↪ To save the password in the browser cache of the local computer click **Save password**.

The main page opens:

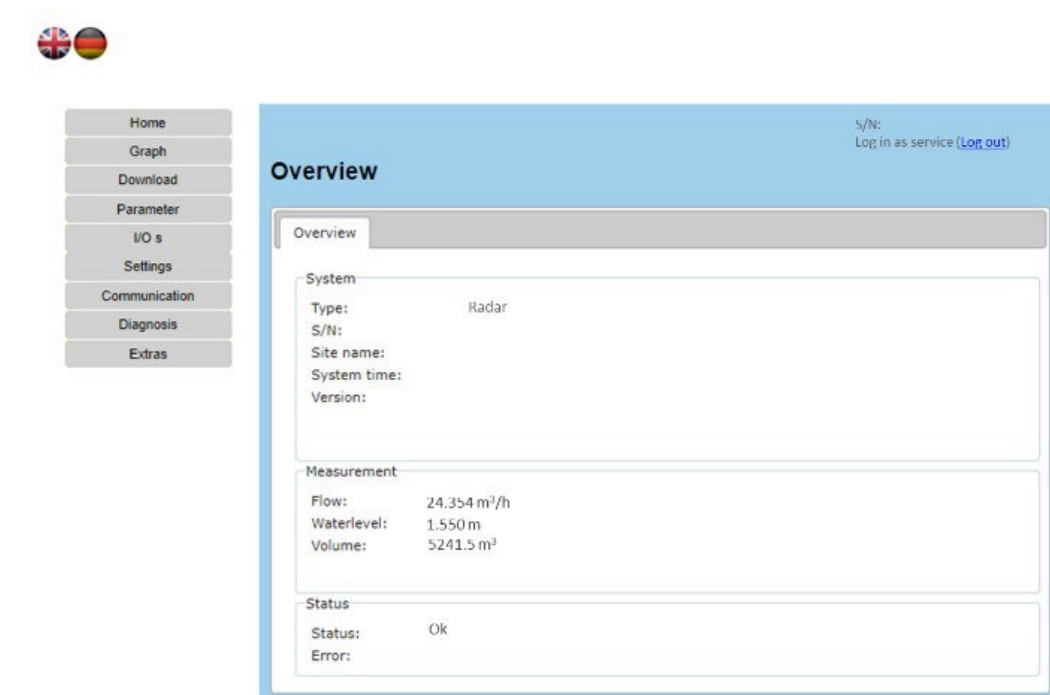

7.1.1 USER GROUPS AND ACCESS RIGHTS

The following user groups with different individual user rights are preset by the manufacturer.

Username (name of user group)	Rights	Password
user	<ul style="list-style-type: none"> • Read data • Read parameters and settings • Download data files 	1234
service	In addition to the rights under the login "user": <ul style="list-style-type: none"> • Set, change and save transmitter settings • Definition of units and user defined measurement parameters • Restart of volume calculation • Software update • Backup and restore settings 	badger6000

NOTICE!

Passwords are predefined and can only be changed by Badger Meter. Badger Meter has full access to the unit and data for online analysis, troubleshooting and debugging.

7.2 Menu structure

The user interface is clearly structured and shows four function areas:

- ① Main menu, ② Sub menu, ③ Language selection, ④ S/N Serial number, Log in / Log out



- ① Home
- Graph
- Download
- Parameter
- I/O s
- Settings
- Communication
- Diagnosis
- Extras

④ Log in as service ([Log out](#))

Overview

Overview ②

System

Type: Radar

S/N:

Site name:

System time:

Version:

Measurement

Flow: 24.354 m³/h

Waterlevel: 1.550 m

Volume: 5241.5 m³

Status

Status: Ok

Error:

- ① Main menu: The main menu consists of the following 9 main menu items:

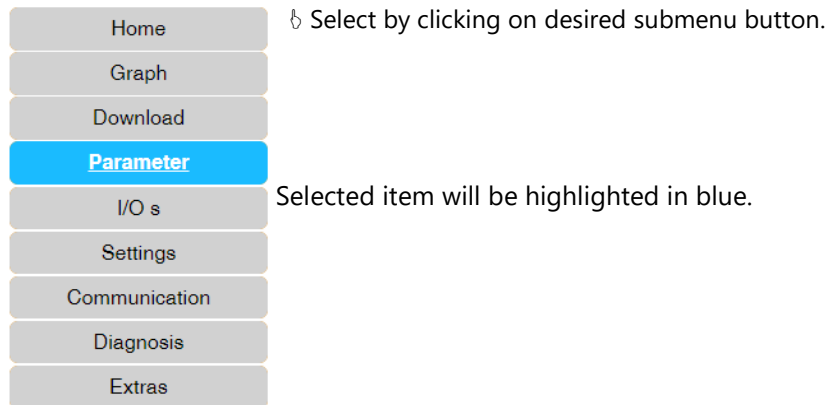

- ② Submenu: Display of selected main menu item with submenus for editing further specific functions and settings.

Example:

Main menu item ► Parameter

Submenus: ▷ Geometry ▷ Water level

▷ Measurement range ▷ Calibration ▷ Replacement

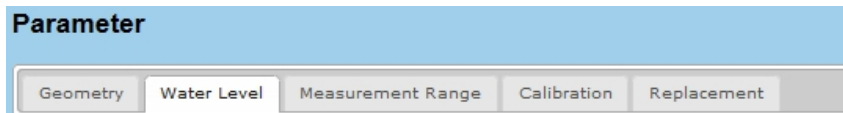

- ③ Flag symbols: Language selection: German, English, French, Spanish, Polish, Japanese, Russian, Czech
Settings for displaying the flag symbols in main menu ► Extras under ▷ Language Location
(see [chapter 7.2.2](#))

- ④ Log in/Log out S/N: At the top right side:

- S/N: Display of serial number of connected flow meter
- display of name of site
- display of username of current user
- **Log-out** function to end the session

7.2.1 OVERVIEW OF MAIN MENU ITEMS AND FUNCTION OF CORRESPONDING SUBMENUS

Home	<p>▷ Overview</p> <p>Overview status of measuring system. (system specification, name measuring site, display current readings, status information, error messages, version no.)</p>
Graph	<p>▷ 3 Days ▷ Current ▷ History ▷ Settings</p> <p>Data visualization (real time data, customized time series)</p>
Download	<p>▷ Download ▷ Setting</p> <p>Data retrieval and customizing settings for data transfer.</p>
Parameter	<p>▷ Geometry ▷ Water level ▷ Measurement range ▷ Calibration ▷ Replacement</p> <p>Parameterization of measuring profile, settings for water level measurement, measurement range, calibration, discharge calculation replacement function.</p>
I/O s	<p>▷ Analog In ▷ Analog Out ▷ Digital In ▷ Digital Out ▷ User values</p> <p>I/Os settings for digital, analog in- and outputs, pulse outputs, user defined outputs.</p>
Settings	<p>▷ Logging ▷ Units ▷ Displayed units ▷ Totalizer</p> <p>Customized settings for data logging, units, volume totalizer.</p>
Communication	<p>▷ Network ▷ SMS ▷ FTP ▷ MODBUS ▷ Serial</p> <p>Selection of communication type (LAN, FTP, Modbus, Serial) / communication interface to sensor, settings for SMS alarm.</p>
Diagnosis	<p>▷ Log Files ▷ Data</p> <p>Display of log-file content for analysis, data summary sheet.</p>
Extras	<p>▷ Language Location ▷ Date Time ▷ LC-Display ▷ Power Management ▷ Backup & Update</p> <p>Settings for language, data transfer, date and time, time synchronization, settings for power management (during battery operation) and options for backup and software update.</p>

For the description of the user interface (GUI) the following symbols are used:	
▶	Main menu item
▷	Submenu
♂	Mouse click, left mouse button
>	Type, enter, etc.
▼	Select from drop-down list
<input type="checkbox"/>	Checkbox, disabled > function not active
<input checked="" type="checkbox"/>	Checkbox, enabled > function active
Update	Commands are written in bold
<u>link</u>	Link; click on <u>link</u> to activate function
[1]	Literature reference

7.2.2 SETTINGS FOR LANGUAGE AND LOCATION

Default language upon first start is English. To change the displayed language, click the main menu item ► **Extras**. The corresponding flag symbol of the selected language will be displayed in the upper left corner of the GUI.

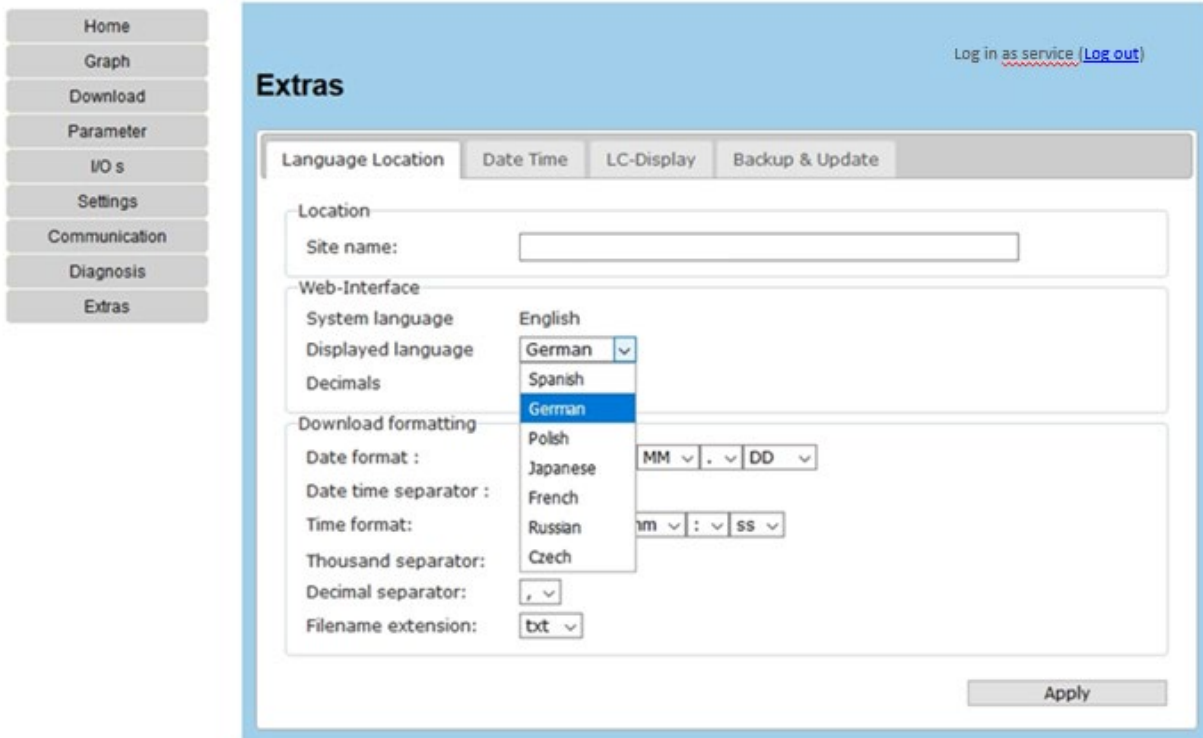

► Language Location

Setting

Description

Location

Site name > Enter name of measuring site.
Site name is displayed on start page ► Home – Overview.

Web-Interface

System language English
Displayed language > Select language from drop-down list.

▼ Spanish
German ...

↪ Click **Apply** to save settings.
The corresponding flag symbol of the selected language will be displayed.
Click the flag symbol to change between languages.

Further settings see chapter [7.11.1](#).

7.3 Home – Overview

- Home
- Graph
- Download
- Parameter
- I/O s
- Settings
- Communication
- Diagnosis
- Extras

► **Home - Overview**

▷ Overview

General information on measuring system and status.

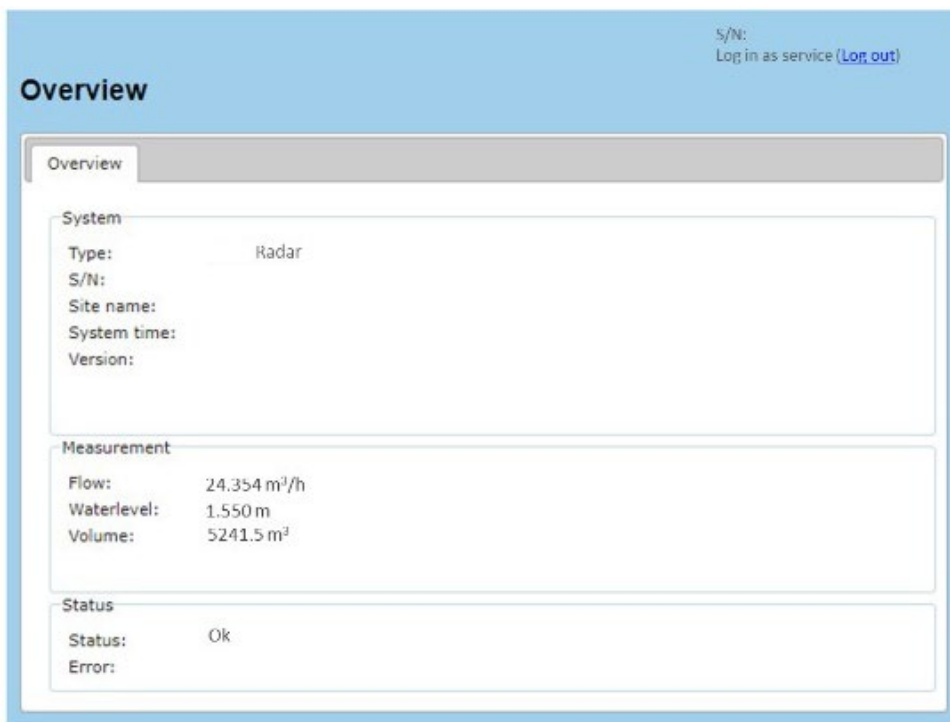

▷ Overview	
Setting	Description
System	
Type	Display name of connected measuring system.
S/N	Display of serial number of measuring system; automatically assigned.
Site name	Display name measuring site. Name entry field in main menu ► Extras under ▷ Language Location
System time	Display system time
Version	Current version numbers of hard- and software fm: version flow meter

	ui: version GUI (user interface).
Measurement	
Flow	Display of current value discharge.
Water level	Display of current water level.
Volume	Display of current value total volume.
Status	
Status	Display device status (OK, ERROR)
Error	Display of date, time, error codes (binary code) and error description (<i>see chapter 8.2.1</i>). <i>Note that on the transmitter LCD the specific error code will not be displayed. Error message displayed on transmitter: ERROR. Refer to user interface for error code.</i>

7.4 Graph - Data visualization

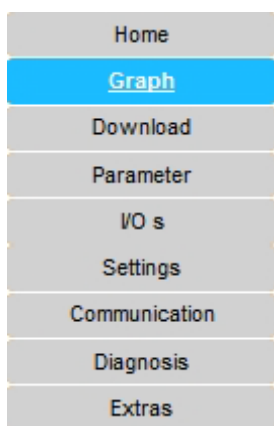

► Graph

▷ 3 Days ▷ Current ▷ History ▷ Settings

This menu provides flexible options for graphical display of data:

- online data presentation (Current)
- data point information by clicking directly on data curve
- data display over a user defined time period, data history (3 Days, History)
- customized parameters, color selection and scaling (Settings)

7.4.1 3 DAYS

Display time series over max. 3 days.

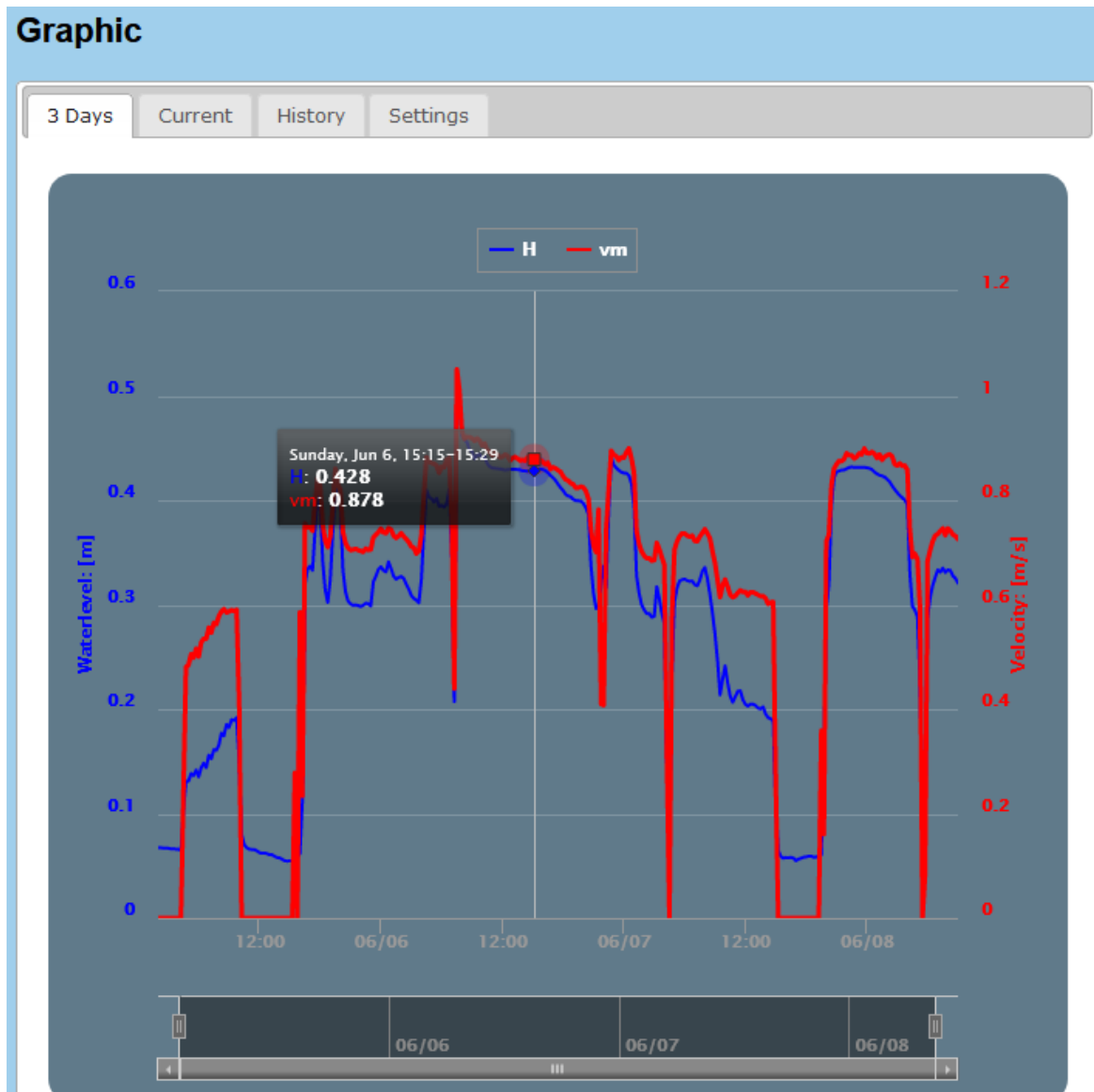

▷ 3 Tage

Setting	Description
3 Days	Data display of last 3 days. ↳ Click on single data point for display of measurement value.
Adjustable time bar	Select time span for data display by adjusting the time bar. The sliders on the sides of the time bar can be dragged in the desired position using the left mouse button.

Manual zoom

Left click and hold in any position on the graph to define the start of the zoom window. Drag the mouse on the graph to choose the end of the zoom area. The selected area will be highlighted in light blue. Release the mouse once you are satisfied with your selection. Click "Reset zoom" on the graph to return to the original view.

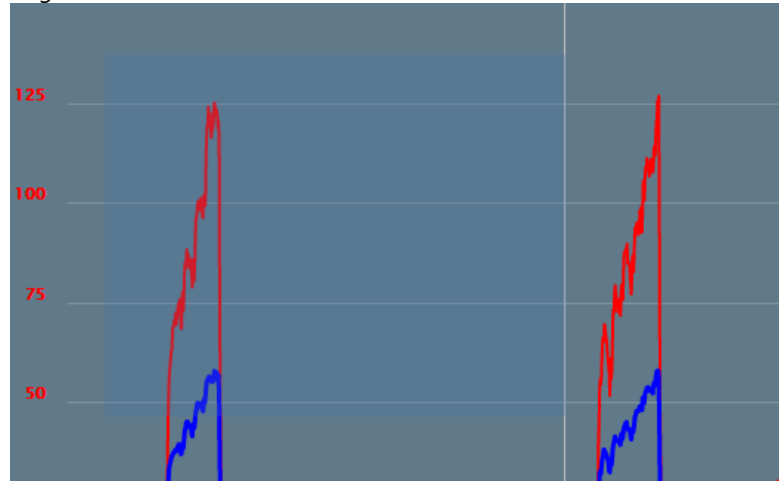

7.4.2 CURRENT

Live / real time data display in customized update interval.

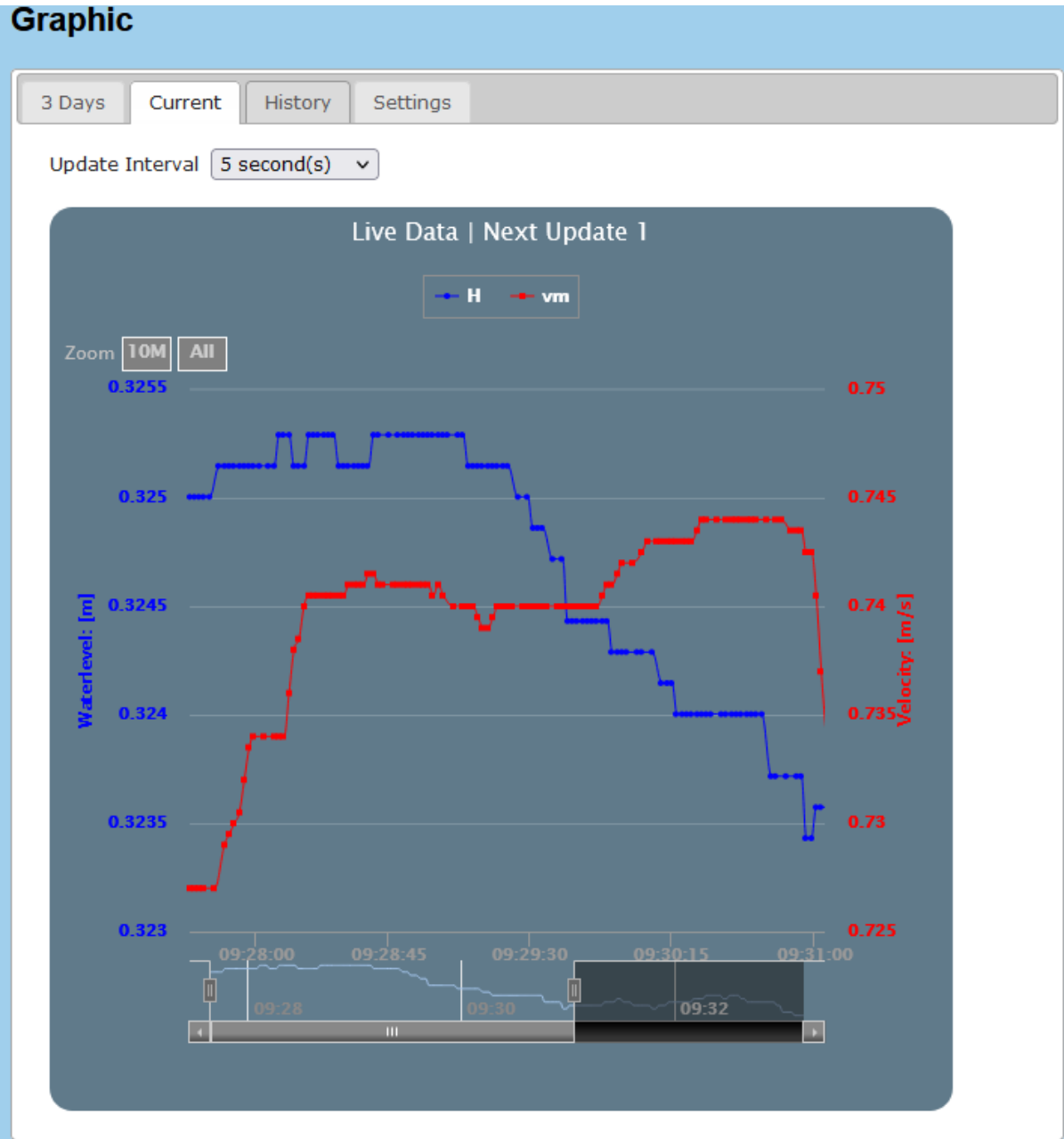

▷ **Current**

Setting	Description
Update Interval ▼ 5 second(s) (...) 30 second(s)	> Select time for data update interval from drop-down list.
Zoom 10M - All	Zoom options data display. ↳ Click 10M to display data of last 10 minutes since opening page in selected update interval. ↳ Click All to display all data since opening page in selected update interval.
	↳ Hover over data points for display of measurement value.
Manual zoom	Left click and drag mouse on the graph to define zoom area. Detailed description in chapter 7.4.1 .
Adjustable time bar	 Select time span for data display by adjusting the time bar. The sliders on the sides of the time bar can be dragged in the desired position using the left mouse button.

7.4.3 [HISTORY](#)

Data display over user-defined time span.

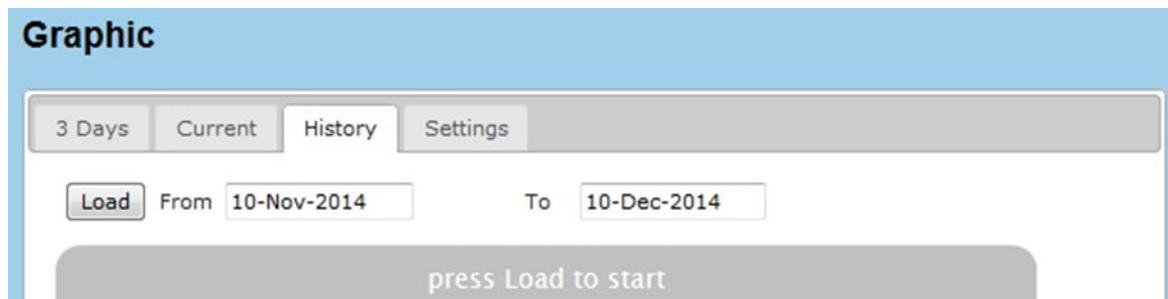

▷ **History**

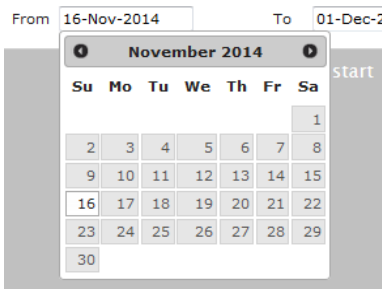
Setting	Description
Load from ... to	> Enter start and end date for time series from drop-down calendar. Only days within the current month can be displayed
	From 16-Nov-2014 To 01-Dec-2014 
	↳ Click Load to display data.

7.4.4 SETTINGS

Parameter selection of the two Y-axes and display options.

▷ Settings

Setting	Description
Background color ▼ Darkblue Lightblue (...)	> Select color for background of graphic.
Y-Left ▼ Discharge Velocity Length (...)	> Select parameter to be displayed on left Y-axis from drop-down list.
Y-Right ▼ Discharge (...)	> Select parameter to be displayed on right Y-axis from drop-down list.
aut. Scale: <input type="checkbox"/>	> <input checked="" type="checkbox"/> Tick checkbox to activate automatic scaling.
Min:	> Enter minimum value to be displayed. (entry only possible if automatic scaling is disabled)
Max:	> Enter maximum value to be displayed. (entry only possible if automatic scaling is disabled)
Name	Display of selected parameter.
Show <input type="checkbox"/>	> <input checked="" type="checkbox"/> Tick checkbox to show listed parameter.
Color ▼ Red Yellow (...)	> Select display color.

7.5 Download - Data transfer

- Home
- Graph
- Download**
- Parameter
- I/O s
- Settings
- Communication
- Diagnosis
- Extras

► Download

▷ Download ▷ Setting

Options for data download.

7.5.1 DOWNLOAD

Settings for data download options.

- Download of current month.
- Download of monthly recorded data.
- Download of data over a user defined period.

Download

Download Setting

Download direct

Size database: MB

First measurement:

Last measurement:

Measurements:

Download monthly

Filename:	Filesize:	
	4.044498 MB	Download
	0.24386 MB	Download
	1.714972 MB	Download
	8.957123 MB	Download

Download selectable

From:

To:

Database:

Prognose:

▷ **Download**

Download direct

Download of raw data in SI units to a CSV-file. Units are not displayed in raw data file.

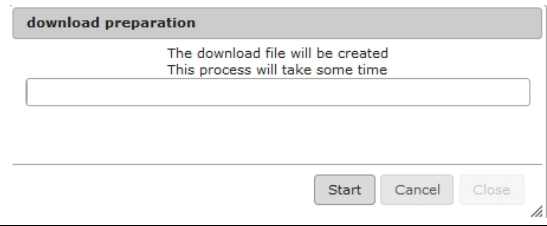
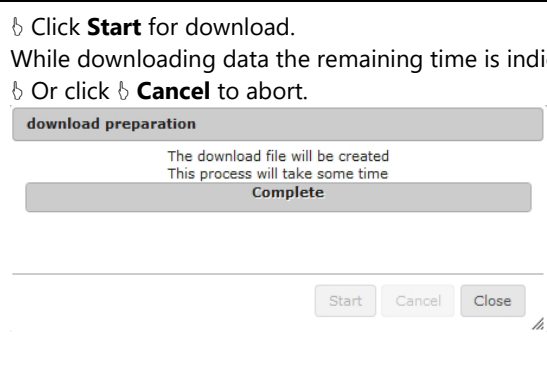
Setting	Description
Size database	Display data base size.
First measurement	Display of date and time of first measurement.
Last measurement	Display of date and time of last recorded measurement.
Measurements	Display of total numbers of measurements.
	↳ Click Download to save data file (data.csv). Depending on your browser settings a dialog box opens to open or save the data file. Confirm with > OK in the dialog box to start data download or press > cancel to abort data transfer.
Download monthly	
Download of monthly recorded data.	
	↳ File name serial no-data_yyyyymm.csv will be displayed and can be downloaded directly by clicking ↳ Download .
Download selectable	
Download of user-defined data sets and units for a user defined period within the current month. Entering dates containing one or more changes of month is not possible. For selection of data sets and units go to ▶ Download ▷Setting. For download format settings see menu ▶ Extras ▷ Language Location.	
From To	> Enter measurement start date from drop-down calendar. > Enter measurement end date from drop-down calendar.
Database	Display of total numbers of measurements.
Prognosis	Display of estimated download time.
	↳ Click Generate File for download preparation. A dialog window opens to display download progress.
	
	↳ Click Start for download. While downloading data the remaining time is indicated. ↳ Or click ↳ Cancel to abort. 

	If download is complete click Close to return to main window. Then click highlighted button Download .
	Depending on your browser settings a dialog box opens to save or open the data file. Select the desired option in the dialog box (e.g. confirm with > OK or > cancel to abort data transfer) to complete data download. Default file name: System name_device serial number_start date yyyyymmdd last date yyyyymmdd.csv

7.5.2 SETTING

Settings for selection of parameters and corresponding units (SI units or displayed units) for download-file under Download selectable.

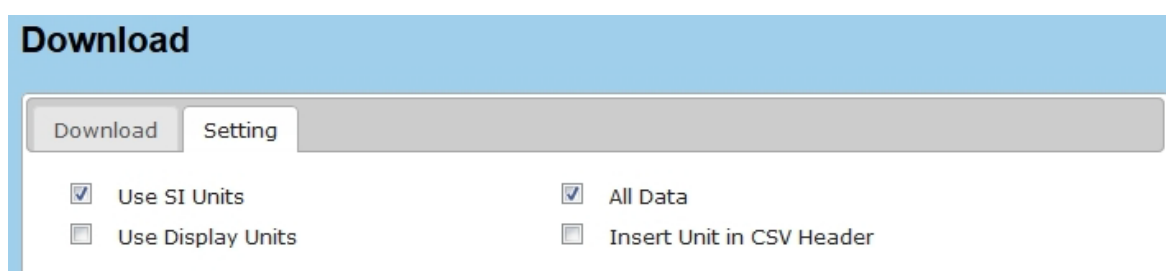

Setting	Description
Use SI units	<input checked="" type="checkbox"/> Tick checkbox to download data in SI units.
Use Display units	<input checked="" type="checkbox"/> Tick checkbox to download data in displayed units. Before you start choosing the data, please check and define the displayed units in the main menu ► Settings under ► Displayed Units.
All Data	<input checked="" type="checkbox"/> Tick checkbox to select all data shown below. Selection of individual parameters: <input type="checkbox"/> Do not tick if you want to select single parameters.
Insert Unit in CSV Header	<input checked="" type="checkbox"/> Tick checkbox to display the units in the downloaded csv-file.
...	In the following list you can also specify single parameters (Length, Time, Time, Q, Velocity, Volume, Temperature, Unitless, Concentration, Signal, Voltage...) for download by ticking the corresponding checkboxes. Note that the list comprises all possible parameters that can be set for the specific transmitter type and not only for the connected system (e.g. values for external water level measurement).

7.6 Parameter – Parameterization

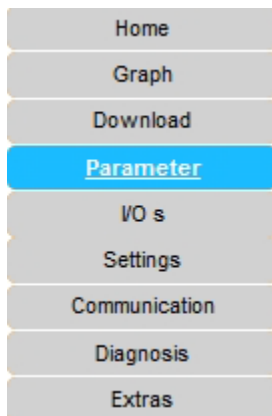

► Parameter

- ▷ Geometry ▷ Water Level ▷ Measurement Range ▷ Calibration
- ▷ Replacement

The menu provides further options for

- Definition of cross-section parameters
- Settings for level measurement
- Parameter setting for discharge calculation
- Calibration
- Replacement function for discharge calculation

7.6.1 GEOMETRY

Definition of cross-section shapes and dimensions, geometrical values of sewers, drains and pipelines (according to DIN 4263 [1]).

Before you start the parameter input, please check and define the displayed units in the main menu ► Settings under ► Displayed Units.

Parameter

Geometry
Water Level
Measurement Range
Calibration
Replacement

Cross section: Rectangular ▼

Rectangular: Circular
Rectangular
U Profile
Trapezoid
J Trapezoid
Egg (DIN 4263)
Mouth (DIN 4263)
Irregular

Width: m

Height: m

Reduction area: m²

Sludge Level: m

▷ **Geometry**

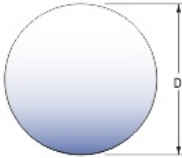
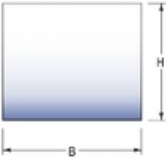
<p>CrossSection ▼ Circular</p>	<p>CrossSection: <input type="text" value="Circular"/></p> <p>Circular:</p>  <p>Diameter: <input type="text" value="0.210"/> m</p> <p>Sludge Level: <input type="text" value="0.000"/> m</p> <p>Reduction area: <input type="text" value="0"/> m²</p>
<p>Diameter</p>	<p>> Enter pipe diameter (D)</p>
<p>Sludge Level</p>	<p>> Enter thickness of sludge / sediment layer (<i>see Fig. 25</i>).</p>
<p>Reduction area</p>	<p>> Enter 0 (recommended) or value for cross section area reduction (e.g. due to installations in the pipe or channel).</p>
	<p>↪ Click Apply to save settings for circular cross-section.</p>
<p>CrossSection ▼ Rectangular</p>	<p>CrossSection: <input type="text" value="Rectangular"/></p> <p>Rectangular:</p>  <p>Width: <input type="text" value="1.000"/> m</p> <p>Height: <input type="text" value="1.000"/> m</p> <p>Reduction area: <input type="text" value="0"/> m²</p> <p>Sludge Level: <input type="text" value="0.000"/> m</p>
<p>Width</p>	<p>> Enter width (B)</p>
<p>Height</p>	<p>> Enter height (H)</p>
<p>Reduction area</p>	<p>> Enter 0 (recommended) or value for cross section area reduction (e.g. due to installations in the pipe or channel).</p>
<p>Sludge Level</p>	<p>> Enter thickness of sludge / sediment layer (<i>see Fig. 25</i>).</p>
	<p>↪ Click Apply to save settings for rectangular cross-section.</p>

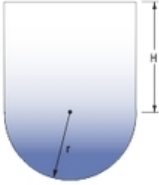
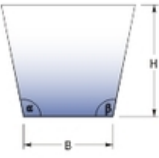
<p>CrossSection ▼ U Profile</p>	<p>CrossSection: <input type="text" value="U Profile"/></p> <p>U Profile:</p>  <p>Height: <input type="text" value="0.190"/> m</p> <p>Radius: <input type="text" value="0.120"/> m</p> <p>Reduction area: <input type="text"/> m²</p> <p>Sludge Level: <input type="text" value="0.000"/> m</p>
<p>Height</p>	<p>> Enter height (H) of cross-section as shown in drawing above.</p>
<p>Radius</p>	<p>> Enter radius of semi circle.</p>
<p>Reduction area</p>	<p>> Enter 0 (recommended) or value for cross section area reduction (e.g. due to installations in the pipe or channel).</p>
<p>Sludge Level</p>	<p>> Enter thickness of sludge / sediment layer (see Fig. 16).</p>
	<p>↪ Click Apply to save settings for U profile cross-section.</p>
<p>CrossSection ▼ Trapezoid</p>	<p>CrossSection: <input type="text" value="Trapezoid"/></p> <p>Trapezoid:</p>  <p>Width: <input type="text" value="0.200"/> m</p> <p>Height: <input type="text" value="0.050"/> m</p> <p>Angle left: <input type="text" value="44"/> °</p> <p>Angle right: <input type="text" value="55"/> °</p> <p>Reduction area: <input type="text" value="0"/> m²</p> <p>Sludge Level: <input type="text" value="0.000"/> m</p>
<p>Width</p>	<p>> Enter width (B).</p>
<p>Height</p>	<p>> Enter height (H).</p>
<p>Angle_left</p>	<p>> Enter left angle (α).</p>
<p>Angle_right</p>	<p>> Enter right angle (β).</p>
<p>Reduction area</p>	<p>> Enter 0 (recommended) or value for cross section area reduction (e.g. due to installations in the pipe or channel).</p>
<p>Sludge Level</p>	<p>> Enter thickness of sludge / sediment layer (see Fig. 16).</p>
	<p>↪ Click Apply to save settings for trapezoid cross-section.</p>

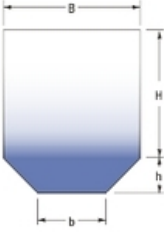
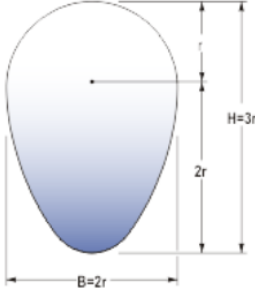
<p>CrossSection ▼ J Trapezoid</p>	<p>CrossSection: J Trapezoid ▼</p> <p>J Trapezoid:</p>  <p>Width B: <input type="text" value="0.000"/> m</p> <p>Width b: <input type="text" value="0.000"/> m</p> <p>Height H: <input type="text" value="0.000"/> m</p> <p>Height h: <input type="text" value="0.000"/> m</p> <p>Reduction area: <input type="text"/> m²</p> <p>Sludge Level: <input type="text" value="0.000"/> m</p>
<p>Width B</p>	<p>> Enter upper width (B).</p>
<p>Width b</p>	<p>> Enter lower width (b).</p>
<p>Height H</p>	<p>> Enter upper height H.</p>
<p>Height h</p>	<p>> Enter lower height h.</p>
<p>Reduction area</p>	<p>> Enter 0 (recommended) or value for cross section area reduction (e.g. due to installations in the pipe or channel).</p>
<p>Sludge Level</p>	<p>> Enter thickness of sludge / sediment layer (see Fig. 16).</p>
	<p>↪ Click Apply to save settings for J trapezoid cross-section.</p>
<p>CrossSection ▼ Egg (DIN 4263)</p>	<p>Cross section: Egg (DIN 4263) ▼</p> <p>Egg (DIN 4263):</p>  <p>Radius: <input type="text" value="0.110"/> m</p> <p>Reduction area: <input type="text" value="0.000"/> m²</p> <p>Sludge Level: <input type="text" value="0.010"/> m</p>
<p>Radius</p>	<p>> Enter radius.</p>
<p>Reduction area</p>	<p>> Enter 0 (recommended) or value for cross section area reduction (e.g. due to installations in the pipe or channel).</p>
<p>Sludge Level</p>	<p>> Enter thickness of sludge / sediment layer (see Fig. 16).</p>
	<p>↪ Click Apply to save settings for egg cross-section.</p>

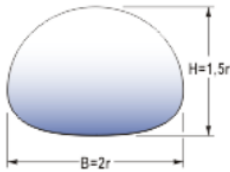
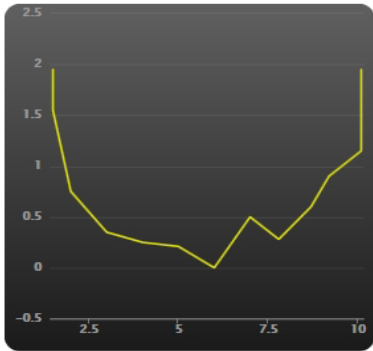
<p>CrossSection ▼ Mouth (DIN 4263)</p>	<p>Cross section: Mouth (DIN 4263) ▼</p> <p>Mouth (DIN 4263):</p> <div style="text-align: center;">  </div> <p>Radius: 0.220 m</p> <p>Reduction area: 0.000 m²</p> <p>Sludge Level: 0.010 m</p>																																																																						
<p>Radius</p>	<p>> Enter radius (r).</p>																																																																						
<p>Reduction area</p>	<p>> Enter 0 (recommended) or value for cross section area reduction (e.g. due to installations in the pipe or channel).</p>																																																																						
<p>Sludge Level</p>	<p>> Enter thickness of sludge / sediment layer (see Fig. 16).</p>																																																																						
<p>↳ Click Apply to save settings for mouth cross-section.</p>																																																																							
<p>CrossSection ▼ Irregular Polynom</p>	<div style="border: 1px solid gray; padding: 5px;"> <p>Geometry Water Level Measurement Range Calibration Replacement</p> <p>CrossSection: Irregular ▼</p> <p>Enable: <input type="checkbox"/></p> <table border="1" style="width: 100%; border-collapse: collapse; text-align: center;"> <thead> <tr> <th>#</th> <th>x-Axis: [m]</th> <th>y-Axis: [m]</th> <th colspan="2"></th> </tr> </thead> <tbody> <tr><td>1</td><td>1.500</td><td>1.950</td><td>+</td><td>-</td></tr> <tr><td>2</td><td>1.500</td><td>1.550</td><td>+</td><td>-</td></tr> <tr><td>3</td><td>2.000</td><td>0.750</td><td>+</td><td>-</td></tr> <tr><td>4</td><td>3.000</td><td>0.350</td><td>+</td><td>-</td></tr> <tr><td>5</td><td>4.000</td><td>0.250</td><td>+</td><td>-</td></tr> <tr><td>6</td><td>5.000</td><td>0.210</td><td>+</td><td>-</td></tr> <tr><td>7</td><td>6.000</td><td>0.000</td><td>+</td><td>-</td></tr> <tr><td>8</td><td>7.000</td><td>0.500</td><td>+</td><td>-</td></tr> <tr><td>9</td><td>7.800</td><td>0.280</td><td>+</td><td>-</td></tr> <tr><td>10</td><td>8.700</td><td>0.600</td><td>+</td><td>-</td></tr> <tr><td>11</td><td>9.200</td><td>0.900</td><td>+</td><td>-</td></tr> <tr><td>12</td><td>10.100</td><td>1.150</td><td>+</td><td>-</td></tr> <tr><td>13</td><td>10.100</td><td>1.950</td><td>+</td><td>-</td></tr> </tbody> </table> <div style="text-align: right;">  <p style="text-align: center;">Redraw</p> </div> </div>	#	x-Axis: [m]	y-Axis: [m]			1	1.500	1.950	+	-	2	1.500	1.550	+	-	3	2.000	0.750	+	-	4	3.000	0.350	+	-	5	4.000	0.250	+	-	6	5.000	0.210	+	-	7	6.000	0.000	+	-	8	7.000	0.500	+	-	9	7.800	0.280	+	-	10	8.700	0.600	+	-	11	9.200	0.900	+	-	12	10.100	1.150	+	-	13	10.100	1.950	+	-
#	x-Axis: [m]	y-Axis: [m]																																																																					
1	1.500	1.950	+	-																																																																			
2	1.500	1.550	+	-																																																																			
3	2.000	0.750	+	-																																																																			
4	3.000	0.350	+	-																																																																			
5	4.000	0.250	+	-																																																																			
6	5.000	0.210	+	-																																																																			
7	6.000	0.000	+	-																																																																			
8	7.000	0.500	+	-																																																																			
9	7.800	0.280	+	-																																																																			
10	8.700	0.600	+	-																																																																			
11	9.200	0.900	+	-																																																																			
12	10.100	1.150	+	-																																																																			
13	10.100	1.950	+	-																																																																			
<p>x-Axis/ y-Axis</p>	<p>> Enter values for width (x)</p> <p>> Enter values for cross section height (y)</p>																																																																						
<p>+ -</p>	<p>↳ Click + to add row for additional values or to delete values.</p>																																																																						
<p>↳ Click Apply to save settings for irregular cross-section.</p>																																																																							

7.6.2 SLUDGE LEVEL

Sludge level > Enter thickness of sediment / sludge layer (see figure below) accumulated on the bottom of a pipe or channel or riverbed. The program will calculate the area covered with sediment or sludge; this value will be subtracted from the total wetted hydraulic area for accurate water level and cross-section measurements.

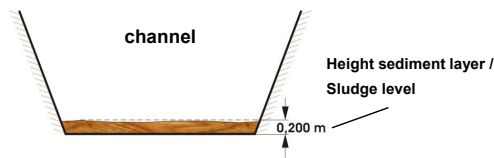

Figure 22: Height sediment layer / Sludge level

7.6.3 WATER LEVEL

Select method for water level measurement:

- H (Extern 1) = water level measurement with external sensor
- H (Fix) = fix value for water level

Parameter

Geometry

Water Level

Measurement Range

Calibration

Replacement

Sensor selection

H (Extern 1)

H (Fix)

Setting	Description
Sensor selection	
W (Extern 1)	> <input checked="" type="checkbox"/> Tick checkbox for water level measurement with an external water level sensor (sensor connection on analog input channel 1). (Value corresponds to database parameter "HWater").
W (Fix)	> <input checked="" type="checkbox"/> Tick checkbox to enter fixed value for water level manually. This may be a suitable option in case of level sensor failure.
	↪ Click Apply to save settings.

7.6.4 MEASUREMENT RANGE

Settings of measurement range and individual measurement task.

Parameter

Geometry
Water Level
Measurement Range
Calibration
Replacement

Limits range

V min m/s

V max m/s

Low flow cutoff

Verify on Q V

Q min m³/s V min m/s

Q max m³/s V max m/s

▷ Measurement Range

Setting	Description	
Limits Range V min V max	> Enter minimum and / or maximum velocity (V) value that will be used for discharge (Q) calculation. This is useful for an automated plausibility check of the measured values.	
	Limits range V min <input type="text" value="30"/> cm/s V max <input type="text"/> cm/s	If no range is set, all V-values of the measurement are used for Q calculation.
	Limits range V min <input type="text" value="30"/> cm/s V max <input type="text"/> cm/s	V- values from 30 cm/s are used for Q calculation. (V > 30 cm/s)
	Limits range V min <input type="text"/> cm/s V max <input type="text" value="1000"/> cm/s	V-values lower than 1000 cm/s are used for Q calculation. (V < 1000 cm/s)
	Limits range V min <input type="text" value="30"/> cm/s V max <input type="text" value="1200"/> cm/s	V-values > 30cm/s and < 1200 cm/s are used for Q calculation. (30 cm/s < V < 1200 cm/s)
Low flow cut off	<div style="border: 1px solid #ccc; padding: 5px; margin-bottom: 10px;"> Low flow cutoff Verify on <input checked="" type="checkbox"/> Q <input type="checkbox"/> V Q min <input type="text"/> l/s V min <input type="text"/> cm/s Q max <input type="text"/> l/s V max <input type="text"/> cm/s </div> <p><i>Values defined in the range of the low flow cut off are set to 0.</i></p> <p>> Enter range of very low and therefore often unsteady discharge (Q) or velocity (V) values which shall not be considered for flow calculation.</p>	

	Measurement values below or within the adjustable range will be set to zero and will also be displayed as zero on the transmitter display.
Verify on Q / V	> <input checked="" type="checkbox"/> Tick checkbox to choose option for Q- or V-values
Q min / Q max V min / V max	> Enter minimum and / or maximum for discharge value. > Enter minimum and / or maximum for velocity value.
	↵ Click Apply to save settings.

7.6.4.1 Sensor parametrization RV11

Sensor parametrization

In general, the mounting angle and the mounting height of the sensor determine the distance to the water surface and the size of the measurement spot. For calculated dimensions of the measurement spot refer to [chapter 9.2, Table 2](#).

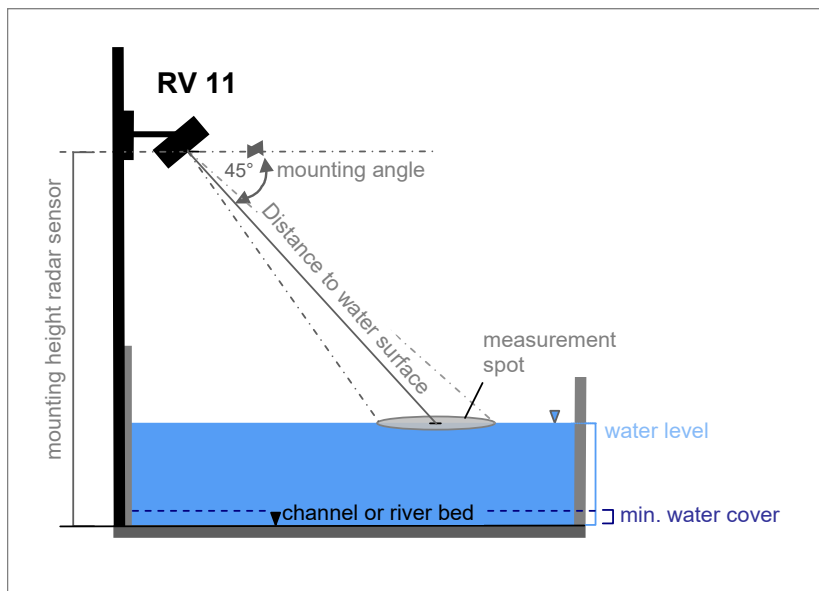

Figure 23: Installation parameters for radar velocity sensor type RV11

	Mounting angle radar sensor: <input type="text" value="45"/> ° Mounting height radar sensor: <input type="text" value="6.000"/> m min signal: <input type="text" value="50"/> dB min. water cover: <input type="text" value="0.050"/> m Switch pos. Flow Dir: <input type="checkbox"/>
Mounting angle radar sensor	> Enter mounting angle (recommended 35° - 45°).
Mounting height radar sensor	<p>A maximum mounting height of 10 m is recommended for the sensor type RV11.</p> <p>> Enter distance for exact mounting height of radar sensor. Measure the distance between centre line of sensor head perpendicular to reference level (site datum) from which water level is measured (see Fig. 23).</p> <p>For regular cross-sections (e.g. rectangular channel shape), normally the channel bed will be taken as reference level and is usually set to 0.</p>

	For irregular cross-sections (e.g. rivers) the reference level may be relative to the mean sea level (MSL) or other reference systems. In that case the value for mounting height of the radar sensor must also be related to the used reference system.
min. Signal	> Enter value for minimal signal strength from which measurement is activated. Option for filtering readings of signal strength. Optimum signal strength: 50 dB
min. water cover	> Enter value for minimal water cover. Option for setting a minimal water cover (<i>see Fig. 23</i>). This value describes the lowest water level from which velocity measurement is most reliable. Below this value no velocity measurement will be performed to exclude inaccurate readings resulting from unwanted reflections e.g. of the river or channel bed.
	<p>Example: Settings for min signal and min water cover: You can either enter a value or leave the field blank. If no values have been set, all measurements will be included in the flow (Q) calculation.</p> <p>The fields are linked with an "or" option. The software will check every velocity measurement within the entered limits / settings.</p> <p>Example settings: Min signal: 55 dB Min water cover: 33 cm</p> <p>v = 1m/s, Signal: 65 dB, water level: 38 cm <input checked="" type="checkbox"/> Q calculation v = 1m/s, Signal: 53 dB, water level: 44 cm <input type="checkbox"/> Q calculation v = 1m/s, Signal: 61 dB, water level: 29 cm <input type="checkbox"/> Q calculation v = 1m/s, Signal: 54 dB, water level: 28 cm <input type="checkbox"/> Q calculation</p> <p><input checked="" type="checkbox"/> Q calculation: measurement considered for Q calculation. <input type="checkbox"/> Q calculation: measurement not considered for Q calculation.</p>
Switch pos. Flow Dir	<input type="checkbox"/> default setting The radar sensor is installed against flow direction. This is the recommended installation position. (Output: positive velocity value +V) > <input checked="" type="checkbox"/> Tick the checkbox to reverse the flow direction in case the radar velocity sensor is installed in flow direction.
	👉 Click Apply to save settings.

7.6.4.2 Sensor parametrization RV24

The mounting angle and the mounting height of the sensor determine the distance to the water surface and the size of the measurement spot. For calculated dimensions of the measurement spot refer to [chapter 9.2, Table 3](#).

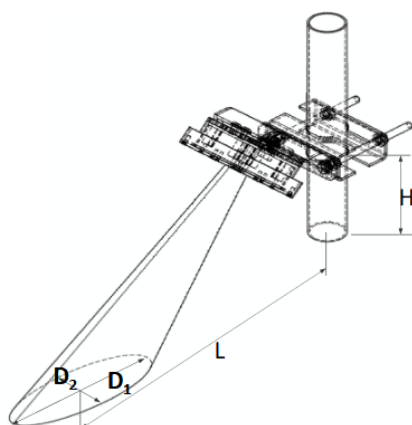

Mounting angle	The mounting angle (recommended 30° - 60°) is automatically measured and recorded by the sensor type RV24.
Mounting height	A maximum mounting height of 20 m is recommended.
	<p>Sensitivity Level: <input type="text" value="50"/></p> <p>PGA Gain Sensitivity: <input type="text" value="4"/> ▾</p> <p>SNR Threshold: <input type="text" value="50"/> dB</p> <p>min. water cover: <input type="text" value="0.050"/> m</p> <p>Switch pos. Flow Dir: <input type="checkbox"/></p>
Sensitivity Level:	<p>Indicates the sensitivity of the measurement. A lower Sensitivity Level allows measurements at greater distances from the surface of the medium.</p> <p>> If the signal strength of the measurement is not sufficient, it is recommended to reduce this value.</p> <p>Factory setting: 55</p>
PGA Gain Sensitivity	<p>Amplification of the sensor signal.</p> <p>Factory setting: 8 (maximum amplification)</p> <p>> If unwanted interference occurs, for example due to signals from the river bank or the channel wall, this value can be reduced.</p>
SNR Threshold	<p>> Enter a value in dBm for the signal-to-noise limit below which all measured values are discarded and displayed as 0.</p> <p>Factory setting: 0 dB, recommended reference value: 5 dB</p>
min. water cover	<p>> Enter value for minimal water cover.</p> <p>This value describes the lowest water level from which velocity measurement will be included in flow calculations.</p> <p>Below this value no velocity measurement will be performed to exclude inaccurate readings resulting from unwanted reflections e.g. of the river or channel bed.</p> <p>Factory setting: 0.000 m, recommended value: 0.100 m</p>
	<p>Example: Settings for min signal and min water cover:</p> <p>You can either enter a value or leave the field blank.</p> <p>If no values have been set, all measurements will be included in the flow (Q) calculation.</p> <p>The fields are linked with an "or" option. The software will check every velocity measurement within the entered limits / settings.</p> <p>Example settings: Min signal: 55 dB Min water cover: 33 cm v = 1m/s, Signal: 65 dB, water level: 38 cm <input type="checkbox"/> p Q calculation v = 1m/s, Signal: 53 dB, water level: 44 cm <input type="checkbox"/> £ Q calculation v = 1m/s, Signal: 61 dB, water level: 29 cm <input type="checkbox"/> £ Q calculation v = 1m/s, Signal: 54 dB, water level: 28 cm <input type="checkbox"/> £ Q calculation</p> <p><input checked="" type="checkbox"/> Q calculation: measurement considered for Q calculation. <input type="checkbox"/> Q calculation: measurement not considered for Q calculation.</p>
Switch pos. Flow Dir	<p><input type="checkbox"/> default setting</p> <p>The radar sensor is installed against flow direction. This is the recommended installation position. (Output: positive velocity value +V)</p> <p>> <input checked="" type="checkbox"/> Tick the checkbox to reverse the flow direction in case the radar velocity sensor is installed in flow direction.</p>
	<p>↳ Click Apply to save settings.</p>

7.6.5 CALIBRATION

A calibration is carried out by comparative measurements with a reference device. An example with 5 reference measurements is shown below.

Parameter

Geometry
Water Level
Measurement Range
Calibration
Replacement

Date	W [m]	Q meas [m ³ /s]	Q ref [m ³ /s]	active	delete
2014-08-01	0.000	0.000	0.000	<input checked="" type="checkbox"/>	<input type="checkbox"/>
2014-08-03	0.000	19.700	19.300	<input checked="" type="checkbox"/>	<input type="checkbox"/>
2014-08-05	0.000	13.500	11.700	<input checked="" type="checkbox"/>	<input type="checkbox"/>
2014-08-07	0.000	28.800	26.800	<input checked="" type="checkbox"/>	<input type="checkbox"/>
2014-08-013	0.000	44.500	37.400	<input checked="" type="checkbox"/>	<input type="checkbox"/>

Active | Q max: m³/s
 Fit | Q min: m³/s
 R-Coefficient

▷ Calibration

Before you start entering values, please check and define the displayed units in the main menu ▶ Settings under ▷ Displayed Units. Enter values for Q meas (Radar) and Q ref (reference device) in table of values:

Setting	Description
Date	> Enter date.
W	> Enter water level.
Q Meas	> Enter measured Q value.
Q Ref	> Enter reference Q value (from reference device).
<input type="checkbox"/> active <input type="checkbox"/> delete	> Tick checkbox to activate or delete value pair for calibration curve.
	↵ Click Apply to save settings. Values are displayed in the list above.

	↳ Click Add Measurement to enter additional values.
Definition and graph of regression for calibration curve within discharge range (Q min / Q max):	
Active <input type="checkbox"/> / <input checked="" type="checkbox"/>	> <input checked="" type="checkbox"/> Tick checkbox to enable curve fitting.
Fit ▼ Linear polynomial 2nd polynomial 3rd polynomial 4rd	> Select curve fitting options from drop-down menu.
Q max	> Enter maximum for discharge value.
Q min	> Enter minimum for discharge value.
R-Coefficient	> Shows calculated regression coefficient.

7.6.6 REPLACEMENT

The replacement function provides different methods to calculate flow (Q). This option is applied in case of sensor failure or if calculation of Q is required below or above preset min. and max. limit values for velocity, water level or signal strength.

Parameter

Geometry
Water Level
Measurement Range
Calibration
Replacement

Behavior of the replacement function

sensor failure

Velocity greater 0 m/s

Waterlevel less 0.9 m

Signal greater 0 dB

Value for waterlevel: HWater

Replacement function calculation:

none

from measurements

Manning

Manning Strickler

from polynom

Apply

Behavior of the replacement function

Defines in which events the replacement function shall be activated.

Setting	Description
<input type="checkbox"/> sensor failure	> <input checked="" type="checkbox"/> Tick checkbox in case of sensor failure.
<input type="checkbox"/> Velocity	> <input checked="" type="checkbox"/> Tick checkbox to activate replacement function, if current measurement value exceeds or falls below the defined limit for flow velocity. > Enter velocity limit value.

	<p>less ▽ = replacement function is activated if current measurement value falls below the defined limit value.</p> <p>greater ▽ = replacement function is activated if current measurement value exceeds the defined limit value.</p>
<input type="checkbox"/> Waterlevel	<p>> <input checked="" type="checkbox"/> Tick checkbox to activate replacement function if current measurement value exceeds or falls below the defined limit for water level.</p> <p>> Enter water level limit value.</p> <p>less ▽ = replacement function is activated if current measurement value falls below the defined limit value.</p> <p>greater ▽ = replacement function is activated if current measurement value exceeds the defined limit value.</p>
<input type="checkbox"/> Signal	<p>> <input checked="" type="checkbox"/> Tick checkbox to activate replacement function if current measurement value exceeds or falls below the defined limit for signal strength.</p> <p>> Enter signal limit in dB</p> <p>less ▽ = replacement function is activated if current measurement value falls below the defined limit value.</p> <p>greater ▽ = replacement function is activated if current measurement value exceeds the defined limit value.</p>
<p>Value for waterlevel</p> <p>▼ H</p> <p> HWater</p> <p> HAir</p>	<p>> Select which water level parameter will be used for checking if replacement function will be applied.</p>
<p>Replacement function calculation</p> <p>Select the calculation method for Q.</p>	
<input type="radio"/> none	<p>> <input checked="" type="radio"/> Tick checkbox if no replacement function shall be used for discharge calculation.</p>
<input type="radio"/> from measurements	<p>> <input checked="" type="radio"/> Tick checkbox to calculate Q from Q/h (stage discharge) relation.</p>

Replacement function calculation:

- none
- from measurements
- Manning
- Manning Strickler
- from polynom

W-Q measurements:

Date	W [m]	Q [m³/h]	active	delete
2014-07-01	0.05	5.00	<input checked="" type="checkbox"/>	<input type="checkbox"/>
2014-07-02	0.08	7.00	<input checked="" type="checkbox"/>	<input type="checkbox"/>
2014-07-03	0.09	7.50	<input checked="" type="checkbox"/>	<input type="checkbox"/>
2014-07-02	0.12	15.00	<input checked="" type="checkbox"/>	<input type="checkbox"/>
2014-07-01	0.16	22.00	<input checked="" type="checkbox"/>	<input type="checkbox"/>
2014-07-01	0.20	36.00	<input checked="" type="checkbox"/>	<input type="checkbox"/>

Fit:
 W min: m
 Q min: m²/h

 W max: m
 Q max: m²/h

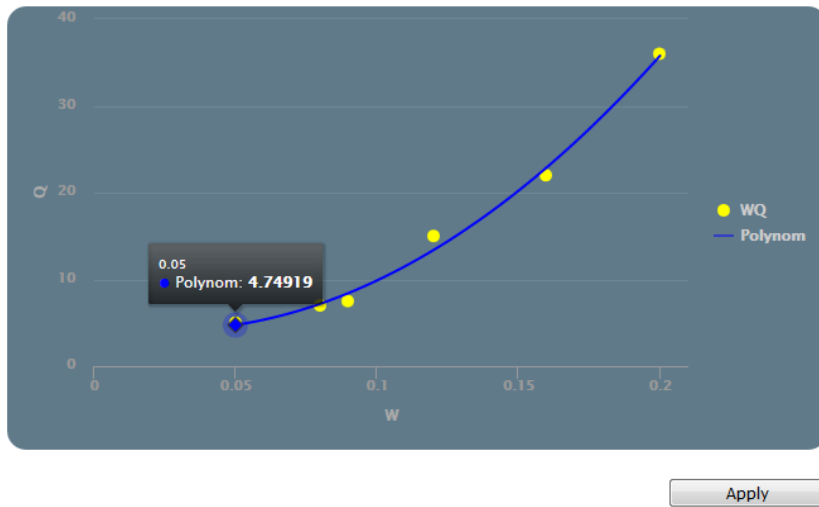

W-Q measurements	Enter values for date and measuring values for W and corresponding Q in table below. Then enter values for date and measuring values for h (W) and corresponding Q in table below.
<input type="checkbox"/> active / delete	> <input checked="" type="checkbox"/> Tick checkbox to activate or delete value pair for W/Q curve.
	↳ Click Add measurement to add new line for additional values.
	↳ Click Redraw to save settings. Values are displayed in the list.
Curve fitting options	The value pairs are plotted in the W/Q graph for rating curve according to approximation settings. The
Fit: ▼ linear polynomial 2 nd (...)	> Select curve fitting options (linear or polynomials up to 6 degrees) from drop-down list.
W min / W max	> Enter minimum / maximum value for water level.
Q min / Q max	> Enter minimum / maximum value for discharge.
	↳ Click Apply to redraw graph.
<input type="radio"/> Manning	> Tick checkbox for empirical discharge calculation according to Manning and enter corresponding parameters (see chapter 11.1).
	Replacement function calculation: <input type="radio"/> none <input type="radio"/> from measurements <input checked="" type="radio"/> Manning <input type="radio"/> Manning Strickler <input type="radio"/> from polynom Manning-Strickler coefficient MaxW: <input type="text"/> m MinW: <input type="text"/> m Slope: <input type="text"/> n-factor: <input type="text"/>
MaxW / MinW	Enter minimum / maximum value for water level. > Enter minimum /

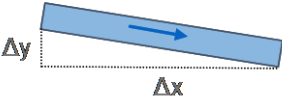
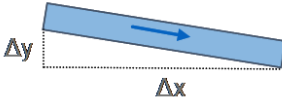
Slope	<p>> Enter value for channel slope. (Dimensionless: $\Delta y / \Delta x$; see below)</p> 
n-factor	<p>Enter specific roughness coefficient n for channel material. (Manning Coefficient) (see Table 4)</p>
	<p>Click Apply to save settings</p>
<input type="checkbox"/> Manning Strickler	<p>> Tick checkbox for empirical discharge calculation according to Manning Strickler and enter corresponding parameters (see chapter 11.1).</p>
	<p>Replacement function calculation:</p> <ul style="list-style-type: none"> <input type="radio"/> none <input type="radio"/> from measurements <input type="radio"/> Manning <input checked="" type="radio"/> Manning Strickler <input type="radio"/> from polynom <p>Manning-Strickler coefficient</p> <p>MaxW: <input type="text"/> m</p> <p>MinW: <input type="text"/> m</p> <p>Slope: <input type="text"/></p> <p>kst-factor: <input type="text"/></p>
MaxW / MinW	<p>> Enter minimum / maximum value for water level.</p>
Slope	<p>> Enter value for channel slope. (Dimensionless: $\Delta y / \Delta x$; see below)</p> 
kst-factor	<p>Enter specific roughness coefficient kst for channel material. (Strickler Coefficient) (see Table 4)</p>
	<p>Click Apply to save settings</p>
<input type="radio"/> from polynom	<p>> Tick checkbox to calculate discharge from polynomial coefficients.</p>
	<p>Replacement function calculation:</p> <ul style="list-style-type: none"> <input type="radio"/> none <input type="radio"/> from measurements <input type="radio"/> Manning <input type="radio"/> Manning Strickler <input checked="" type="radio"/> from polynom <p>Polynomcoefficients</p> <p>c0: <input type="text" value="0.00028"/></p> <p>c1: <input type="text" value="0"/></p> <p>c2: <input type="text" value="0"/></p> <p>c3: <input type="text" value="0"/></p> <p>c4: <input type="text" value="0"/></p> <p>c5: <input type="text" value="0"/></p> <p>c6: <input type="text" value="0"/></p>
Polynomcoefficients c0 ... c6	<p>> Enter coefficients of desired polynomial fitting / regression.</p>
	<p>Click Apply to save settings.</p>

7.7 I/Os – Digital and analog in- and outputs

- Home
- Graph
- Download
- Parameter
- I/O s
- Settings
- Communication
- Diagnosis
- Extras

► I/Os

▷ Analog In ▷ Analog Out ▷ Digital In ▷ Digital Out ▷ User values

Parameterization for analog and digital in- and outputs, pulse output and user-defined outputs.

7.7.1 ANALOG IN

Parameterization and settings for analog connected sensors (water level sensors, sensors for user defined parameters).

Setting	Description
Channel ▼ 1,2,3,4	Assignment of available channels for connected sensors. > Select desired channel (analog input) from drop-down list.
Value ▼ HWater, HAir, None	> Select the connected external water level sensor type for preselected channel from drop-down list. Always connect the external water level sensor to channel 1 and choose HWater as the value. HWater corresponds to the water level sensor H (Extern 1) that can be selected for discharge calculation in the main menu under ► Parameter ▷ Water Level (see chapter 7.6.3) HWater = External water level sensor connected on channel 1. HAir = Not functional for this device type None: No analog sensor is connected.
Settings	
Measurement	> Select the method of water level measurement (water level / distance).

<p>Measurement ⊙ Waterlevel</p>	<p>The sensor measures the water level from bottom to water surface (height of water column). The user defined water level range of the selected sensor is proportional to the input current range. Example: 0-10 m water level measuring range 0/4 mA \triangleq 0 m water level and 20 mA \triangleq 10 m water level</p> <p>Choose this option for parameterization of all water level sensor types provided by Badger Meter. Even if non-contact sensors are used, the distance values are converted to water level values by the sensor.</p>
<p>W max</p>	<p>> Enter max. water level value for max. current input value: Example: water level measurement range 0-10 m: 20 mA \triangleq 10 m water level Select corresponding unit for water level (length).</p>
<p>W min</p>	<p>> Enter min. water level value for min. current input value: 0 mA \triangleq 0 m water level Select corresponding unit for water level (length).</p>
<p>Measurement ⊙ Distance</p>	<p>The water level sensor is mounted above water surface and measures the distance from sensor surface to the water surface. In this case, a high water level means a smaller distance to the sensor and vice versa. Example: distance measuring range 0-10 m: 0 mA \triangleq 0 m distance (= 10 m water level) 20 mA \triangleq 10 m distance (= 0 m water level)</p>
<p>Max. Distance</p>	<p>> Enter max. distance value for the min. current input value: Example for 0-10 m water level measuring range: 0 mA \triangleq 10 m distance (= 0 m water level) Select corresponding unit for distance (length).</p>
<p>Min. Distance</p>	<p>> Define min. distance for max. current input value: 20 mA \triangleq 0 m distance (=10 m water level) Select corresponding unit for distance (length).</p>
<p>Sensor offset</p>	<p>Depending on the sensor position and orientation in the cross section, the measured water level value must be corrected by an offset value to obtain correct readings. By entering the sensor offset, the measured water level value is automatically corrected by the offset value.</p> <p>Example: The water level sensor is installed 1.00 m below water surface and indicates W = 1.00 m. However, the water-level according to the gauge board = 1.05 m. Consequently, the offset value is 0.05 m and the water level value is corrected by 0.05 m.</p> <p>There are two options to obtain the offset value:</p> <p>Option 1: Enter the offset value for the installed water level sensor (fix value). For example: 0.05 m</p> <p style="text-align: center;"> Sensor Offset <input type="text" value="0.05"/> m <input type="button" value="Calculate"/> </p> <p>Option 2: The offset value will be calculated by a reference measurement. The measured water level is compared internally with the reference water level (e.g. from reference device or staff gauge) and the corresponding is calculated and displayed.</p> <p>👉 Click Calculate.</p> <p style="text-align: center;"> Sensor Offset <input type="text" value="0.000"/> m <input type="button" value="Calculate"/> </p> <p>> Enter current water level value (measured by a reference device, staff gauge).</p>

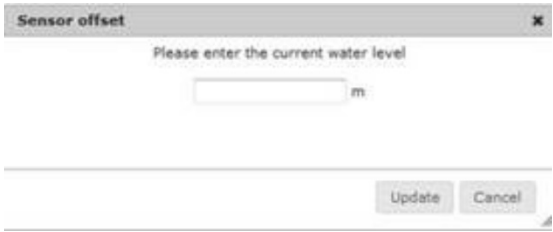
	 <p>Click Update to apply calculated offset value for measurement values or Cancel to abort.</p>
Input range ▼ 4-20 0-20	> Select the current input range in mA from drop-down menu.
Current value	Display of actual input current.
	Click Apply to save settings.

7.7.2 ANALOG OUT

Parameterization of analog outputs.

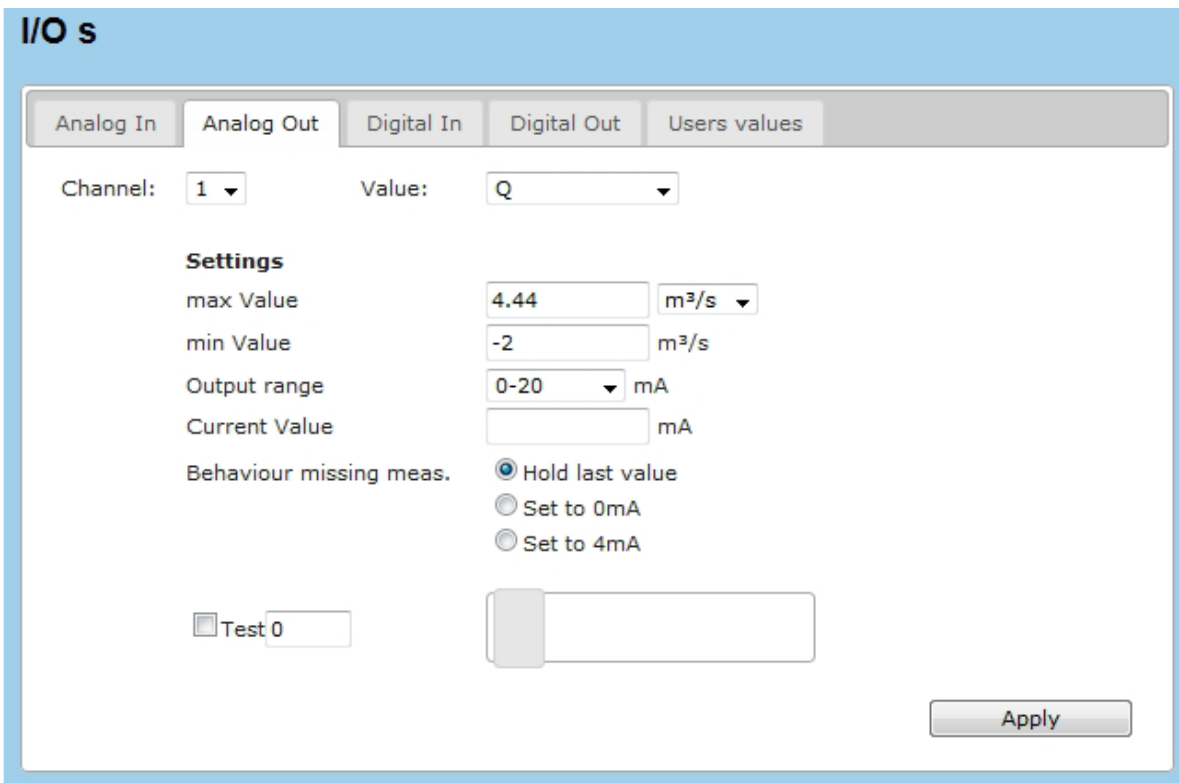

▷ Analog Out

Setting	Description
Channel ▼ 1,2,3,4	> Assignment of available channels. Select desired channel (analog output) from drop-down list.
Value ▼ DVol (...)	> Select measured value / parameter from drop-down list corresponding to channel; the corresponding unit is displayed. (e.g. Q)

Settings	
max Value	> Enter maximum for selected parameter. Select corresponding unit.
min Value	> Enter minimum for selected parameter.
Output range ▼ 4-20 0-20	> Select current output range in mA from drop-down menu.
Current value	> Display of actual output current.
Behaviour missing meas.	Choose between the following options in case of missing measuring values. <input type="radio"/> Hold last value Tick if exported value is missing. The last current/ voltage is main-tained. <input type="radio"/> Set to 0 mA Measurement output value is set to 0 mA. <input type="radio"/> Set to 4 mA Measurement output value is set to 4 mA.
<input type="checkbox"/> Test	> <input checked="" type="checkbox"/> Tick checkbox to enable test. Adjust test bar to different values.
	↳ Click Apply to save settings.

7.7.3 DIGITAL IN

Settings for connection on digital input.

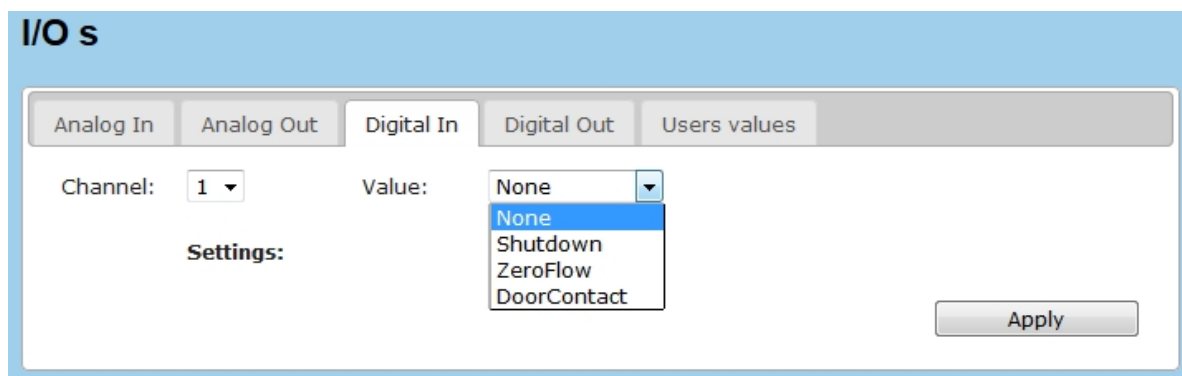

▷ Digital In

Setting	Description
Channel ▼ 1,2	> Assignment of available channels. Select channel for corresponding value from drop-down list.
Value ▼ None Shutdown ZeroFlow	> Select corresponding function for selected channel from drop-down list. None: default setting, no signal Shutdown: system shutdown (reboot) after predefined delay time. ZeroFlow: during signal input discharge is set to „zero“ DoorContact: function for signals of door contact (for monitoring door status).
Settings	
Delay (only applicable for „Shutdown“)	> Enter time (delay time) in seconds; after delay period the system reboots.
	↳ Click Apply to save settings.

7.7.4 DIGITAL OUT

Different signal types can be exported as digital output signals. Assignment of pulse output signals.

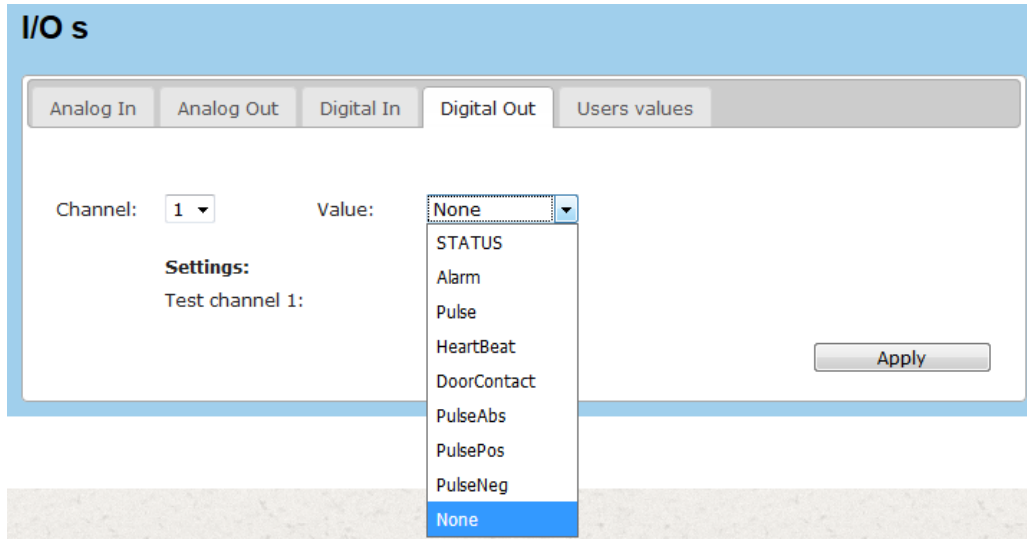

▷ Digital Out

Setting	Description
Channel ▼ 1...8	Available channels for assignment of values. > Select channel for corresponding value from drop-down list.
Value ▼ None STATUS Alarm Pulse HeartBeat DoorContact PulseAbs PulsePos PulseNeg None	> Select value from drop-down list to define alarm signal via relay for selected parameters.
Value ▼ STATUS	> Select STATUS for export of error message The STATUS value corresponds in the software to a binary bit field where each bit reflects an information. With the help of a bit mask this information can be filtered out and exported through the digital output. > STATUS = Error codes (= bit mask)
Settings	Channel: <input type="text" value="1"/> Value: <input type="text" value="STATUS"/> Settings: Mask: <input type="text" value="1"/> Delay: <input type="text" value="0.5"/> s Inverted: <input type="checkbox"/> Test channel 1: <input type="checkbox"/> Test value 1: Low <input type="radio"/> High <input type="radio"/>

Mask	> Enter bit mask no. (currently 1 for bit mask error codes)
Delay	> Enter delay time in seconds between change of status and the setting of the digital channel.
Invertiert	<p>Option to invert digital output signal.</p> <p><input checked="" type="checkbox"/> Tick checkbox to invert signal.</p> <p>Example: Mask value is 1. If bit 0 is set in STATUS the output signal is not active (de-energized), if bit 0 in STATUS is not set the output signal is active (energized).</p> <p><input type="checkbox"/> Output signal is not inverted. Example: Mask value is 1. If bit 0 is set in STATUS field the output signal is active (energized), if bit 0 is not set in STATUS, the output signal is not active (de-energized).</p>
Test channel 1	> <input checked="" type="checkbox"/> Tick checkbox to activate signal test.
Test value 1	Specify low or high signal. <input checked="" type="radio"/> Low / <input type="radio"/> High
	↵ Click Apply to save settings.
Value ▼ Alarm	> Select Alarm from drop-down list to define alarm signal via relay for selected parameters.
	<p>Channel: <input type="text" value="1"/> Value: <input type="text" value="Alarm"/></p> <p>Settings:</p> <p>Measurement value: <input type="text" value="Q"/></p> <p>Limit : <input type="text"/> <input type="text" value="m³/s"/></p> <p>Type: <input checked="" type="checkbox"/> above <input type="checkbox"/> below</p> <p>Hysteresis: <input type="text"/></p> <p>Delay: <input type="text"/> s</p> <p>Test channel 1: <input type="checkbox"/></p> <p>Test value 1: Low <input type="radio"/> <input checked="" type="radio"/> High</p>
Measurement value	> Select desired parameter for alarm signal from drop-down list.
Limit	> Enter value for alarm activation.
Art	Specify alarm activation above or below set limit. <input checked="" type="checkbox"/> above Tick to trigger alarm above limit. <input checked="" type="checkbox"/> below Tick to trigger alarm below limit.
Hysteresis	> Enter hysteresis value to define upper and lower limit which has to be exceeded to trigger an alarm (limit ± hysteresis). A suitable hysteresis value prevents the alarm from being triggered unnecessarily by small measurement deviations.
Delay	> Enter minimum time span for measuring values exceeding the upper or lower limit. Only after this time an alarm is activated. This option avoids that an alarm is activated due to short term deviations.
Test Channel 1	> <input checked="" type="checkbox"/> Tick checkbox to activate signal test. Specify low or high signal.

Test Value 1	Legen Sie die Signalthöhe fest. <input checked="" type="radio"/> Low / <input type="radio"/> High
	↳ Click Apply to save settings.
Value ▼ Pulse PulseAbs PulsePos PulseNeg	Settings for pulse output signals for volume counter (totalizer). 4 types of counters (totalizer) can be parameterized taking into account the flow direction (positive +V against flow direction / negative -V in flow direction). See also under ► Settings ▷ Totalizer (7.8.4)
	Pulse: Volume value - difference (+/- sign are taken into account in summation of V) V = +V (volume positive) -V (volume negative)
	PulseAbs: Absolute volume (- sign of negative volume is not taken into account in summation) V abs (absolute volume) = V (volume positive) + V (amount volume negative)
	PulsePos: Total positive volume (+V) (V against flow direction)
	PulseNeg: Total negative volume (-V) (V in flow direction)
	> Select pulse types from drop-down list to define pulse output and export total volume values.
	<p>Channel: <input type="text" value="1"/> Value: <input type="text" value="Pulse"/></p> <p>Settings:</p> <p>Sum: <input type="text" value="50"/> m³</p> <p>Width: <input type="text" value="500"/> ms</p> <p>Test channel 1: <input type="checkbox"/></p> <p>Test value 1: Low <input checked="" type="radio"/> High <input type="radio"/></p>
Sum	> Select volume value to trigger pulse. (e.g. 50 m3: 1 pulse is triggered per 50 m3)
Width:	> Enter value for pulse width. Default value: 500 ms
Test Channel 1	<input checked="" type="checkbox"/> Tick checkbox to activate signal test.
Test Value 1	Specify low or high signal <input checked="" type="radio"/> Low / <input type="radio"/> High
	↳ Click Apply to save settings.
Value ▼ HeartBeat	> Select HeartBeat to monitor that system is running. (Every 30 s the system sends a ping/signal).
	<p>Channel: <input type="text" value="1"/> Value: <input type="text" value="HeartBeat"/></p> <p>Settings:</p> <p>Test channel 1: <input type="checkbox"/></p> <p>Test value 1: Low <input type="radio"/> High <input type="radio"/></p>

Test Channel 1	<input checked="" type="checkbox"/> Tick checkbox to activate signal test.
Test Value 1	Specify low or high signal <input checked="" type="radio"/> Low / <input type="radio"/> High
	↳ Click Apply to save settings.
Value ▼ DoorContact	> Select DoorContact from drop-down list to define pulse output (relay) for door monitoring.
	Channel: <input type="text" value="1"/> Value: <input type="text" value="DoorContact"/> Settings: Test channel 1: <input type="checkbox"/> Test value 1: <input type="radio"/> Low <input type="radio"/> High
Test Channel 1	<input checked="" type="checkbox"/> Tick checkbox to activate signal test.
Test Value 1	Specify low or high signal <input checked="" type="radio"/> Low / <input type="radio"/> High
	↳ Click Apply to save settings.

7.7.5 USER VALUE

Definition of user defined measurement parameters for the connection of max. 4 additional sensors.

I/O s

Analog In

Analog Out

Digital In

Digital Out

Users values

1. Measurement parameter:

2. Measurement parameter:

3. Measurement parameter:

4. Measurement parameter:

▷ Users values

Setting	Description
1. Measurement parameter	> Enter measurement parameter and corresponding unit of additional connected sensor.
2. Measurement parameter	> Enter measurement parameter and corresponding unit of additional connected sensor.
3. Measurement parameter	> Enter measurement parameter and corresponding unit of additional connected sensor.
4. Measurement parameter	> Enter measurement parameter and corresponding unit of additional connected sensor.
	↳ Click Apply to save settings.

7.8 Settings – Data logging and display

- Home
- Graph
- Download
- Parameter
- IO s
- Settings
- Communication
- Diagnosis
- Extras

► Settings

▷ Logging ▷ Units ▷ Displayed Units ▷ Totalizer

Settings for data logging and log-file logging, settings for displayed units, user defined units, settings for totalizer.

7.8.1 LOGGING

Specifications for data and log file logging. Note that log files contain important information for troubleshooting and debugging in case of system failure.

Settings

Logging
Units
Displayed Units
Totalizer

Type: Median ▼

Database

Duration: 1 year ▼

Interval: 1 ▼ minute(s)

Log Files

Duration: 90 day(s)

Number of Displayed Lines: 80

Trace Level: High ▼

Screen Refresh Interval: 15 ▼ second(s)

Output

Averaging: 60 second(s)

Apply

▷ Logging

Setting	Description
Type ▼ Mean Median	> Select type for average calculation.
Database	

Duration ▼ 1 month – 5 years	> Select time span in month for database history from drop-down list.
Interval ▼ 30 s, ..., 60 min	> Select time span for recording the average value in the database from drop-down list.
Log Files	
Duration	> Enter time span in days after log-file is deleted.
Number of Displayed Lines	> Enter number lines of log-file to be displayed in main menu ► Diagnosis under ▷ Log Files.
Trace Level ▼ low middle high	> Select trace level for display of log-file content. E.g. Trace Level Less: log-file contains less detailed information than log-file Trace level High (Default: Low)
Screen Refresh interval ▼ 15, 30, 60	> Select time span in seconds for log file refresh in the menu ► Diagnosis ▷ Log Files (see 7.10.1).
Output	
Averaging	> Enter time span of measurements in seconds that is used for the average calculation (mean or median). Averaging time should not be smaller than database interval.
	↵ Click Apply to save settings.

7.8.2 UNITS

Free user defined setting of units for the following parameters:

- discharge (Q)
- velocity (v)
- length (l)
- area (A)
- time (t)
- voltage (U)
- temperature (T)
- signal
- volume (V)
- concentration

Conversion factors of common measurement units are already specified. New units can be defined and added by the user.

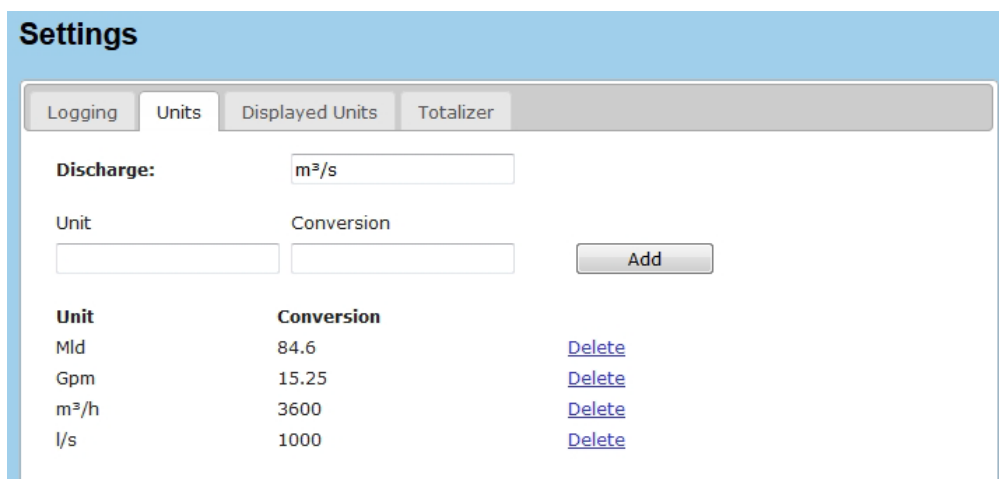

▷ **Units**

Definition of displayed unit for listed parameter.

Setting	Description		
Discharge	reference unit:	m ³ /s	(cubic meters per second)
	available units:	l/s m ³ /h Mld Gps Gpm Gph Gpd MGpd Acrefoot_ph Acre-foot_pd Acre foot pm	(liter per second) (cubic meters per hour) (mega liters per day) (US gallons per second) (US gallons per minute) (US gallons per hour) (US gallons per day) (mega US gallons per day) (acre foot per hour) (acre foot per day) (acre foot per month)
Velocity	reference unit:	m/s	(meter per second)
	available units:	km/h ft/s ft/h cm/s	(kilometer per hour) (feet per second) (feet per hour) (centimeter per second)
Length	reference unit:	m	(meter)
	available units:	km mm cm ft in	(kilometer) (millimeter) (centimeter) (feet) (inches)
Area	reference unit:	m ²	(square meter)
	available units:	cm ² ft ² in	(square centimeter) (square feet) (square inches)
Time	reference unit:	s	(seconds)
	available units:	min ms µs ns	(minutes) (milliseconds) (microseconds) (nanoseconds)
Voltage	reference unit:	V	(volt)
	available units:	mV	(millivolt)
Temperature	reference unit:	°C	(degrees Celsius)
	available units:	F	(degrees Fahrenheit)
Signal	reference unit:	dB	(decibels)
Volume	reference unit:	m ³	(cubic meters)
	available units:	l Ml USGallon ft ³ Acre-foot K_USGallon M_USGallon	(liter) (mega liter) (US gallons) (cubic feet) (acre foot) (thousand US gallon) (mega US gallon)
Concentration	reference unit:	ppt	(parts per trillion; corresponds to conc. = 10 ⁻¹² g/kg)
	available units:	psu	(practical salinity unit)
Unit	> Enter desired unit.		
Conversion	> Enter conversion factor related to reference unit.		
	↵ Click Add to save selected unit.		
	↵ Click Delete to delete entry.		

7.8.3 DISPLAYED UNITS

Choose specific measurement units for parameters to be displayed in graphs, input masks of the web interface and data files (*Download selectable, see 7.5.1*). The units available in the drop-down menus can be defined in the menu **Units** (*see 7.8.2*).

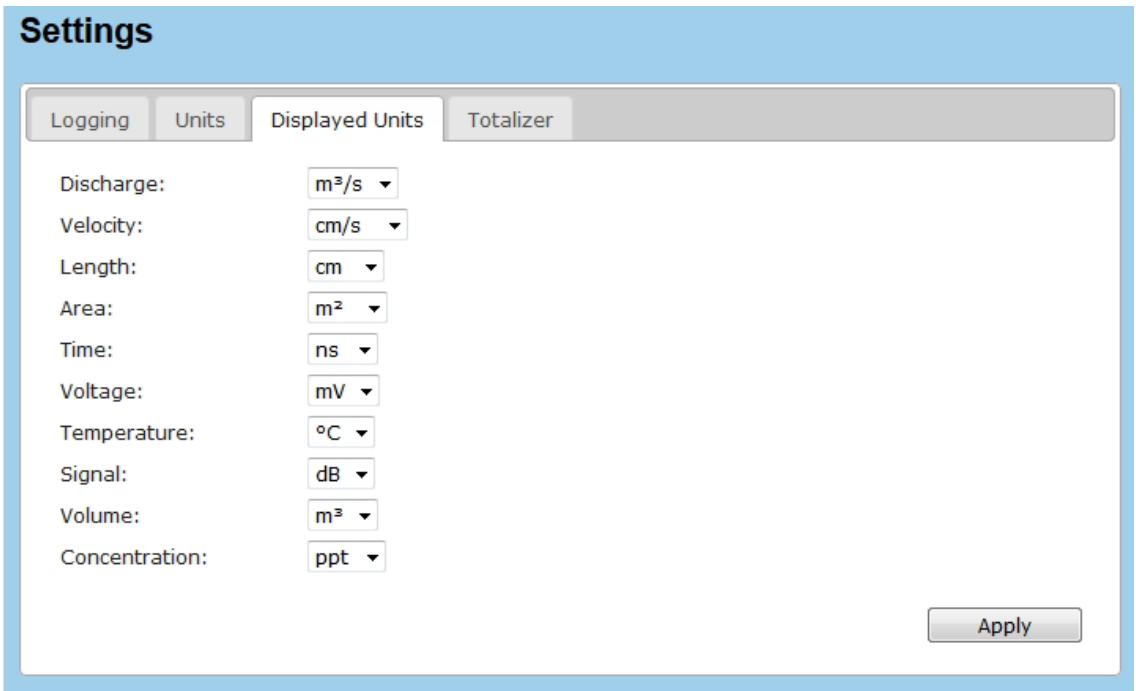

► Displayed Units

Setting	Description
Parameter: Discharge Velocity Length Area Time Voltage Temperature Signal Volume Concentration	> Select desired unit from drop-down lists. Example: Drop-down list for units for discharge; Units in the list to be defined under ► Settings ► Units
	↳ Click Apply to save settings.

7.8.4 TOTALIZER

Totalizer function for measurement and display of total and daily volume values (V).

Flow is measured in either direction (bi-directional):

Volume positive +V (in flow direction), Volume negative -V (against flow direction)

Please note that this definition is only valid if the radar velocity sensor is facing against the flow direction. If the radar velocity sensor is mounted in flow direction, volumes in flow direction are registered as negative (-V).

Define the required unit for Volume under ► Settings ► Displayed Units (*see chapter 7.8.3*)

Settings

Logging
Units
Displayed Units
Totalizer

Total volume

Total volume: 30626062.000 m³

Daily volume from 2019/1/2

Daily volume: 825045.000 m³

Daily volume absolute: 825045.000 m³

Daily volume positive: 825045.000 m³

Daily volume negative: 0.000 m³

Volume since last reset

Volume: 30626062.000 m³

Volume absolute: 30626062.000 m³

Volume positive: 30626062.000 m³

Volume negative: 0.000 m³

Reset

▷ **Totalizer**

Setting	Description
Total volume	
Total volume	Internal sum counter of total volume since first system start > Display of volume value measured since first system start / first commissioning. This value cannot be reset to zero.
Daily volume from YYYY/MM/DD	
Daily volume	Daily volume counter (V difference) > Display of daily volume value +/- sign are taken into account in summation of V V (daily volume) = +V (volume positive) -V (volume negative)
Daily volume absolute	> Display absolute volume per day (day total) (- sign of negative volume is not taken into account!) V (daily volume absolute) = V (volume positive) + V (amount volume negative)
Daily volume positive	Positive counter (+ V): > Display of daily volume <u>in</u> flow direction (positive value)
Daily volume negative	Negative counter (-V): > Display of daily volume <u>against</u> flow direction (negative value)
Volume since last reset	
Volume	Volume counter (V difference) > Display of volume value +/- sign are taken into account in summation of V V (volume) = +V (volume positive) -V (volume negative)
Volume absolute	> Display absolute volume (- sign of negative volume is not taken into account!) V (volume absolute) = V (volume positive) + V (amount volume negative)

Volume positive	Positive counter: > Display of volume <u>in</u> flow direction
Volume negative	Negative counter: > Display of volume <u>against</u> flow direction
	↳ Click Reset to reset volume counters.

7.9 Communication – Network settings

- Home
- Graph
- Download
- Parameter
- I/O s
- Settings
- Communication**
- Diagnosis
- Extras

► Communication

▷ Network ▷ SMS ▷ FTP ▷ MODBUS ▷ Serial

Settings for communication with transmitter and data transfer.

7.9.1 NETWORK

Specification of network type (LAN or GSM/WLAN) and basic network settings.

Communication

Network
SMS
FTP
MODBUS
Serial

Network: LAN ▼

LAN
GSM

DHCP:

IP:

Subnet:

Gateway:

7.9.1.1 LAN connection

► Network

Setting	Description
Network: ▼ LAN GSM	> Select network type LAN from drop-down. ▼ LAN
DHCP <input checked="" type="checkbox"/>	DHCP aktivieren / deaktivieren <input checked="" type="checkbox"/> Enable <input type="checkbox"/> disable DHCP > <input checked="" type="checkbox"/> DHCP (Dynamic Host Configuration Protocol) enabled.

	(factory setting) DHCP is activated and the IP address, Subnet and Gateway are automatically assigned by the server.
IP	Display IP address (automatically assigned).
Subnet	Display subnet mask (automatically assigned).
Gateway	Display gateway address (automatically assigned).
	↪ Click LAN to confirm entry.

7.9.1.2 Manual input und changing of IP address

If a static IP address is required (e.g. if no DHCP server is available) the network parameters can be assigned manually. Change the following settings:

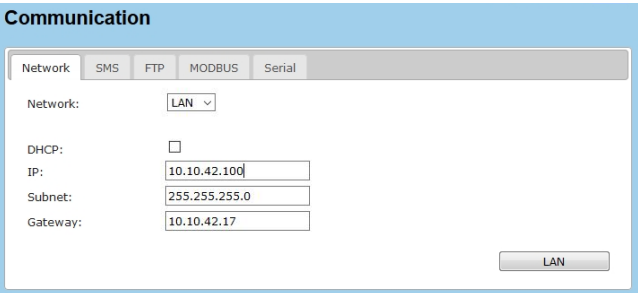
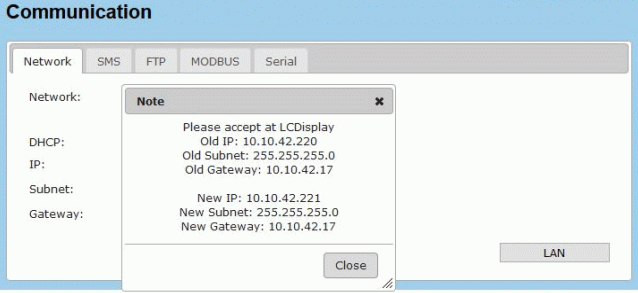
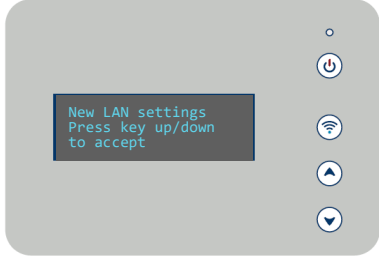
DHCP <input type="checkbox"/>	<input type="checkbox"/> Enable DHCP. 	
IP	> Enter new IP address.	
Subnet	> Enter new subnet mask.	
Gateway	> Enter new gateway.	
	↪ Click LAN to save entries. The following dialog box is displayed: 	
	Now check the transmitter LC-Display. The following message is shown:	
		> Confirm the new LAN settings by pressing one of the navigation keys. (⬆ up or ⬇ down).

If the new LAN settings are not accepted, the message will appear again after every restart of the system until the settings are confirmed by pressing a navigation key.

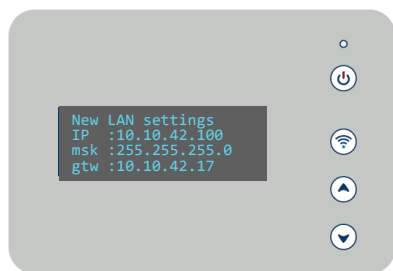

After pressing a navigation key, the new LAN settings are displayed.

Note that the existing network connection is disconnected automatically after the settings have been changed! Restart your web browser and enter the new IP address in the address bar to re-connect to the device.

7.9.1.3 GSM network

<p>Network: ▼ LAN GSM</p>	<p>> Select network type GSM from drop-down list for communication via GSM network. ▼ GSM</p>
<p>Note that the settings for GSM network vary according to the device type:</p> <p>Device with external 3G/2G router: When using an external 3G/2G router, no settings are required at this point. The router configuration is carried out via an integrated web interface. An additional router configuration manual will be provided to ensure correct connection and configuration.</p> <p>Device with integrated 4G/3G/2G modem: When using the integrated option, note that the modem is completely preconfigured by the manufacturer. Settings can be checked under the menu point <u>Modem configuration</u> via the modem user interface (see under "GSM network settings for Doppler with integrated 4G/3G/2G modem" on the following pages).</p>	
<p>GSM network settings for Radar without 3G/2G router or 4G/3G/2G modem</p>	
<p>Access data for log-in are obtained from the service/ network provider.</p>	
<p>Access Point Name</p>	<p>> Enter Access Point Name APN of service/network provider.</p>
<p>User</p>	<p>> Enter username.</p>
<p>Password</p>	<p>> Enter password.</p>
<p>Number</p>	<p>> Enter dial-up phone number of service/network provider.</p>

GSM IP	> Enter GSM IP.
	<p>Click GSM to save your entries.</p> <p>The IP address is displayed after successful login.</p>

GSM network settings for Radar with integrated 4G/3G/2G modem	<p>For network settings only GSM type is needed (see below).</p> <p>Note that upon delivery, the integrated 4G/3G/2G modem is already pre-configured by <i>Badger Meter</i>. Just connect the dipole-antenna on the bottom of the enclosure and insert the SIM card to automatically connect to your provider.</p>
--	--

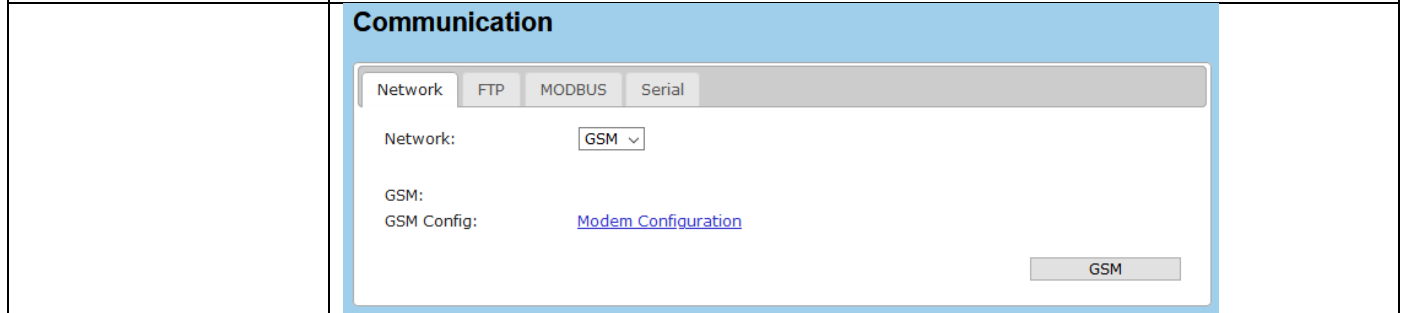

	<p>Note that APN, username and password are given by the network provider of the SIM Card (network profile).</p> <p>To avoid possible misconfigurations, do not change parameters. Change settings only if you have the appropriate experience.</p>
--	---

Modem Configuration	To check or change the settings of the configuration
GSM Config	<p>Click Modem Configuration</p> <p>The WebUI interface of the original modem manufacturer opens.</p> <p>The functions are described in the following.</p> <p>Note that the configuration is saved when the "Save" button is clicked, and the configuration is applied at the next system boot.</p>

	<p>Overview</p> <p>Information regarding the cellular connectivity is displayed.</p> <p> bottom left: display of current GSM connectivity</p> <p>Always ensure that the device is registered in the GSM network and has sufficient signal strength.</p>
--	---

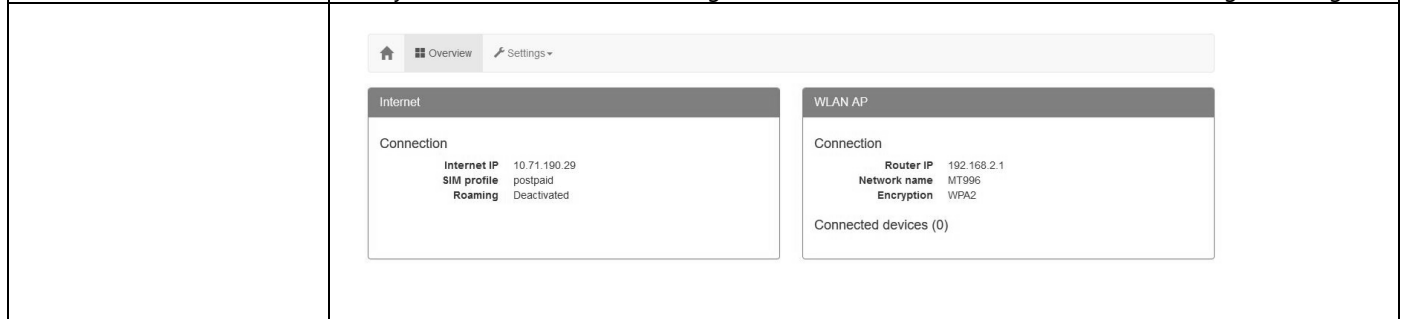

	Internet
Connection	
Internet IP	IP address assigned by provider
SIM profile	Profile name
Roaming	deactivated (factory setting / default setting)
	WLAN AP

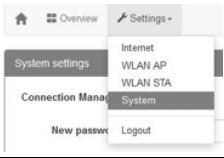
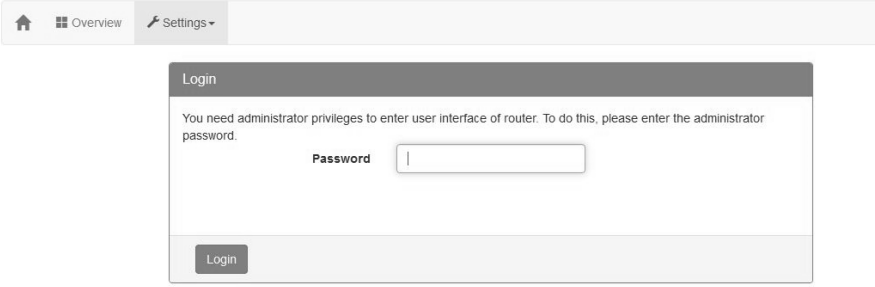
	Connection Router IP Network name Encryption	IP address network SSID of the WiFi access point Encryption WiFi access point
	Settings ▼ Internet WLAN AP WLAN STA System	
		
	Login	
	Password	Enter password: admin

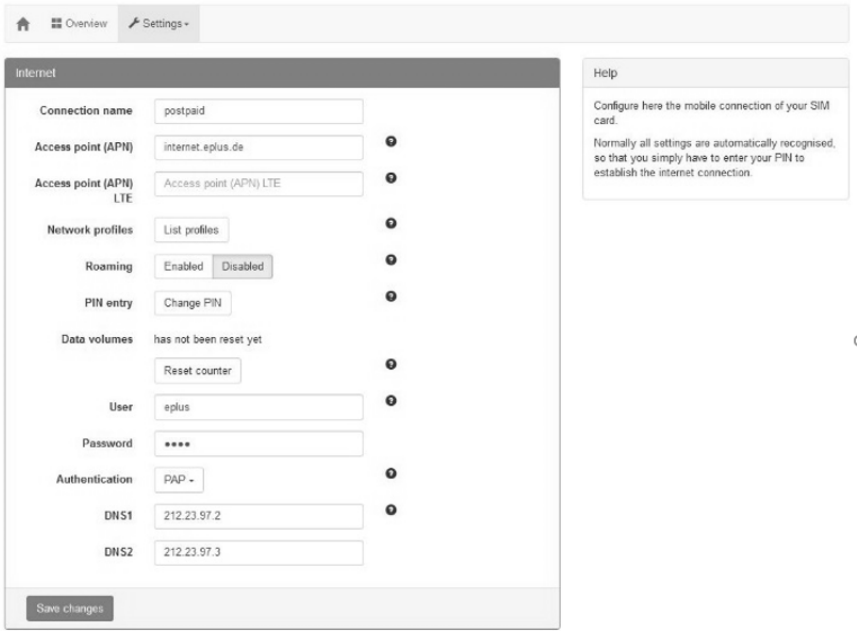
	Internet	
		
	Connection name:	The settings for the SIM card are administered under a freely definable connection name. By default, this is usually the name of the cellular provider. The connection name can be changed manually.
	Access point (APN):	The Cellular subsystem tries to determine the access settings automatically based on the SIM card and stores them in the SIM card profile. It is possible to change the settings here manually.

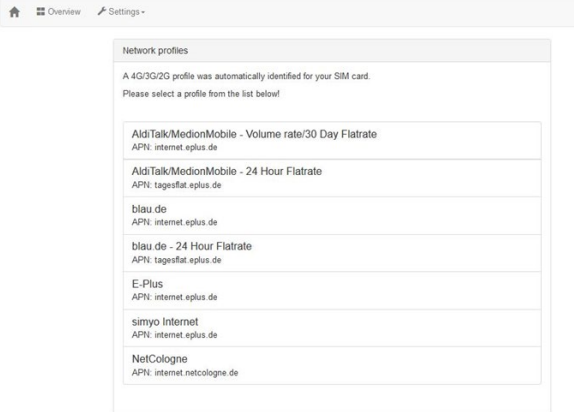
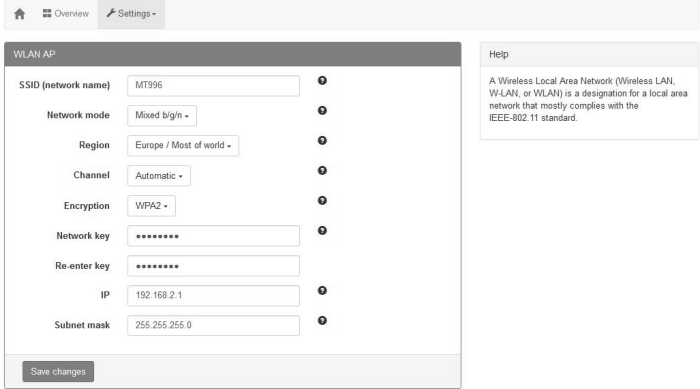
	<p>Access point (APN) LTE:</p>	<p>Since the Access Point for LTE network may be different from the Access point for 2G/3G network, it is possible to change the settings here manually.</p>
	<p>Network profiles:</p>	<p>By clicking this button, it is possible to choose a cellular network profile from a preinstalled list.</p> 
	<p>Roaming:</p>	<p>This switch enables or disables the data roaming. With data roaming switched off, the router will not establish a connection when the cellular module is located outside of the home network. In the factory-programmed settings, the roaming is deactivated.</p>
	<p>PIN entry:</p>	<p>The PIN is requested when the SIM is inserted for the first time and generally must not be changed. If needed, change or set the PIN of the SIM card using the PIN dialog window.</p>
	<p>Data volumes:</p>	<p>The volume counter displayed in the status bar at the bottom indicates the amount of data transferred with the SIM card in megabytes (downloaded/uploaded) since the last reset. The counters can be reset clicking the "Reset counters" button.</p>
	<p>User:</p>	<p>This field sets the username to be used if authentication is required to establish a data connection to the cellular network.</p>
	<p>Password:</p>	<p>This field sets the password to be used if authentication is required to establish a data connection to the cellular network.</p>
	<p>Authentication:</p>	<p>This field sets the authentication procedure selection (PAP, CHAP, no authentication).</p>
	<p>DNS1:</p>	<p>This field specifies a static domain name server.</p>
	<p>DNS2:</p>	<p>This field specifies a second static domain name server.</p>
<p><i>The cellular network profile and configuration is tied to the individual SIM card.</i></p>		
<p>WLAN AP WLAN AP" configures the Wi-Fi access point connectivity.</p>		
		

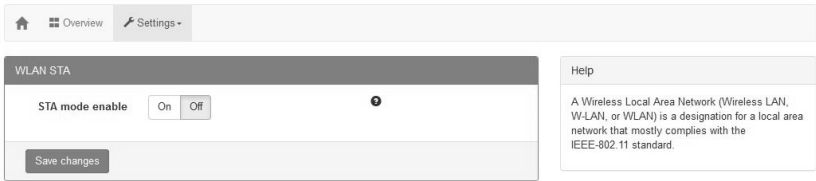
	SSID (Network name):	This field determines the SSID of the Wi-Fi access point. The factory-programmed value is "UBXWifi".
	Network mode:	The network mode determines the IEEE 802.11 standard of the Wi-Fi network. The factory-programmed value is "Mixed b/g/n".
	Region:	This field determines the regulatory domain. Depending on the region, specific channels are faded in or hidden. The factory-programmed value depends on the TOBY-L2 module version.
	Channel:	This field determines the channel of the Wi-Fi access point. The factory-programmed value is "Automatic".
	Encryption:	This field determines the encryption of the Wi-Fi access point. The factory-programmed value is "WPA2".
	Network key:	This field is used to define the WPA/WPA2 key. The factory-programmed value is "ubx-wifi". The key must be suitable for the encryption method.
	Re-enter key:	This field is used for confirming the network key to prevent incorrect entries.
	IP:	This field determines the IP address of the Wi-Fi access point. The factory-programmed value is "192.168.2.1".
	Subnet mask:	Subnet mask: This field determines the subnet mask of the Wi-Fi access point. The factory-programmed value is: "255.255.255.0".
	<p>WLAN STA "WLAN STA" configures the connectivity to an external hotspot. Enable „WLAN STA“. (STA mode enable: on)</p> <p>The router/modem is no longer operated as access point but as client!</p>	
		

System System" is used for several system configurations.	
Connection Manager:	This switch enables or disables the Connection Configuration Manager.
New password:	This field is used to change the system password.
Repeat password:	This field is used for confirming the system password to prevent incorrect entries.
Password protection:	This switch determines the protection level of web pages. If the "Settings page" option is set, then the Wi-Fi / Cellular subsystem router will only ask for a password when entering the settings page. On the other hand, if the "All pages" option is selected, then all the tabs of the Wi-Fi / Cellular subsystem web interface will be password protected.
Language:	This multiple-choice switch is used to select the output language of the WebUI.
Reset device:	The "System reset" button reboots the Wi-Fi / Cellular subsystem router, while the "Factory reset" button resets the Wi-Fi / Cellular subsystem to the factory-programmed values.
Web page FTP access:	The switch enables or disables the FTP access to the Web page files. The customer is allowed to personalize the aspect of the WebUI. The WebUI aspect may be reverted via AT command.

7.9.2 FTP

FTP (File Transfer Protocol) configuration.

Communication

Network
FTP
MODBUS
Serial

Enable

Type: HydroCenter ▾

Server: 87.106.68.228

Port: 21

User: hvttest

Password: ●●●●●●●● unmask

Remote Directory: /4GTest/

Push Interval: 300 ▾ second(s)

Export Interval: 1 second(s)

Backup time: 9000 minute(s)

System ID: MT995

Passive:

	Measurement	Unit	
Measurement: 1:	H ▾	m ▾	-
Measurement: 2:	vm ▾	m/s ▾	-
Measurement: 3:	Q ▾	m³/s ▾	-
Measurement: 4:	A ▾	m² ▾	-
Measurement: 5:	GsmSig ▾	▾	-
	+		

Apply

▷ FTP

Setting	Description
Enable <input type="checkbox"/>	> <input type="checkbox"/> Tick checkbox to enable / disable FTP.
Type ▼ HydroCenter Ott binär XRZP	> Select the data format from drop-down list.
Server	> Enter server IP address. Do not enter a name!
Port	> Enter port number.
User	> Enter username.
Password	> Enter password.
Remote Directory	> Enter directory name on server.
Push Interval ▼ 3600, ... , 300	> Select interval for file push. Unit: s (seconds)

Export Interval	> Enter the interval at which data should be written to the push file. The export interval should not be greater than the push interval.
Backup time	> Enter time span for the temporary data storage until the next data transmission.
System ID	> Enter system ID.
Suffix <i>only for type Ott binär and XRZP</i>	> Enter file extension (e.g. .csv)
Passive	> <input checked="" type="checkbox"/> Tick checkbox to enable FTP passive modus.
Measurement ▼ None A H (...)	Specify measured values for data transfer. > Select measured values / parameters from drop-down list; corresponding units are displayed. (Explanation of abbreviations see 7.12.)
Unit ▼	> Select desired unit for the value.
<input type="button" value="+"/> <input type="button" value="-"/>	Click + to add row for additional values or – to delete values.
Click Apply to save settings.	

7.9.3 MODBUS

MODBUS is a client-server communication protocol used for communication between electronic devices to exchange data mainly in the industrial environment.

A Modbus RTU interface (RS485/RS232) or an Ethernet interface with Modbus TCP protocol are available for communication.

Communication

Network
FTP
MODBUS
Serial

Modbus settings:

Enable:

Type: RTU

ID: 42

Baudrate: 9600

Modbus slave:

Register	Value	Unit	Datatype	
1	Q	m³/s	Float	<input type="button" value="-"/>
2	Status		Integer	<input type="button" value="-"/>
3	TotalVolume	m³	Integer	<input type="button" value="-"/>
4	H	m	Float	<input type="button" value="-"/>
5	vm	m/s	Float	<input type="button" value="-"/>

Modbus master:

#	Value	Unit	Datatype	Register	ID	
1	HAir	m	Float	0	172.19.1	<input type="button" value="-"/>

▷ Modbus

Setting	Description																																			
Modbus Settings																																				
Enable <input type="checkbox"/>	> <input checked="" type="checkbox"/> Tick checkbox to enable / disable Modbus.																																			
Type ▼ TCP RTU	> Select Modbus TCP or RTU protocol type from drop-down list.																																			
Type ▼ TCP	> Select TCP <div style="border: 1px solid #ccc; padding: 5px; margin: 5px 0;"> Modbus settings: Enable: <input type="checkbox"/> Type: TCP ▼ Port: 502 </div>																																			
Port	> Enter TCP port number used for Modbus TCP server protocol. Default setting: Port 502																																			
Type ▼ RTU	Select Modbus RTU protocol type for data transmission via internal interface RS485/RS232. <div style="border: 1px solid #ccc; padding: 5px; margin: 5px 0;"> Modbus settings: Enable: <input checked="" type="checkbox"/> Type: RTU ▼ ID: 42 Baudrate: 9600 ▼ </div>																																			
ID	> Enter device / flowmeter identification number (modbus address).																																			
Baudrate ▼ 115200 (...) 1200	> Select desired baud rate from drop-down list.																																			
Modbus slave	Definition of data transfer if system is used as slave. <div style="border: 1px solid #ccc; padding: 5px; margin: 5px 0;"> Modbus slave: <table border="1" style="width: 100%; border-collapse: collapse;"> <thead> <tr> <th>Register</th> <th>Value</th> <th>Unit</th> <th>Datatype</th> <th></th> </tr> </thead> <tbody> <tr> <td>1</td> <td>Q ▼</td> <td>m³/s ▼</td> <td>Float ▼</td> <td style="text-align: center;">-</td> </tr> <tr> <td>2</td> <td>DVol ▼</td> <td>▼</td> <td>Integer ▼</td> <td style="text-align: center;">-</td> </tr> <tr> <td>3</td> <td>H ▼</td> <td>cm ▼</td> <td>Float ▼</td> <td style="text-align: center;">-</td> </tr> <tr> <td>4</td> <td>Status ▼</td> <td>▼</td> <td>Integer ▼</td> <td style="text-align: center;">-</td> </tr> <tr> <td>5</td> <td>vm ▼</td> <td>m/s ▼</td> <td>Float ▼</td> <td style="text-align: center;">-</td> </tr> <tr> <td colspan="5" style="text-align: left; padding-top: 5px;">+ Add new register</td> </tr> </tbody> </table> </div>	Register	Value	Unit	Datatype		1	Q ▼	m³/s ▼	Float ▼	-	2	DVol ▼	▼	Integer ▼	-	3	H ▼	cm ▼	Float ▼	-	4	Status ▼	▼	Integer ▼	-	5	vm ▼	m/s ▼	Float ▼	-	+ Add new register				
Register	Value	Unit	Datatype																																	
1	Q ▼	m³/s ▼	Float ▼	-																																
2	DVol ▼	▼	Integer ▼	-																																
3	H ▼	cm ▼	Float ▼	-																																
4	Status ▼	▼	Integer ▼	-																																
5	vm ▼	m/s ▼	Float ▼	-																																
+ Add new register																																				
+ -	> Click + to add row for additional register or – to delete register.																																			
Register	Number of register.																																			
Value ▼ none A (...)	> Specify parameter for selected register.																																			

Unit	Display of corresponding units. > Select desired unit from drop-down menu.																					
Datatype ▼ Float Integer LongInt	> Select data transmission format from drop-down list.																					
Modbus Master	Definition of data transfer if system is used as master.																					
For RTU	<div style="border: 1px solid #ccc; padding: 5px;"> Modbus master: <table border="1" style="width: 100%; border-collapse: collapse;"> <thead> <tr> <th>#</th> <th>Value</th> <th>Unit</th> <th>Datatype</th> <th>Register</th> <th>ID</th> </tr> </thead> <tbody> <tr> <td>1</td> <td>HAir</td> <td>m</td> <td>Float</td> <td>0</td> <td>172.19.0</td> </tr> <tr> <td colspan="6" style="text-align: center;">+</td> </tr> </tbody> </table> </div>	#	Value	Unit	Datatype	Register	ID	1	HAir	m	Float	0	172.19.0	+								
#	Value	Unit	Datatype	Register	ID																	
1	HAir	m	Float	0	172.19.0																	
+																						
For TCP	<div style="border: 1px solid #ccc; padding: 5px;"> Modbus master: <table border="1" style="width: 100%; border-collapse: collapse;"> <thead> <tr> <th>#</th> <th>Value</th> <th>Unit</th> <th>Datatype</th> <th>Server</th> <th>Port</th> <th>Register</th> </tr> </thead> <tbody> <tr> <td>1</td> <td>HAir</td> <td>m</td> <td>Float</td> <td>172.19.80.88</td> <td>9000</td> <td>0</td> </tr> <tr> <td colspan="7" style="text-align: center;">+</td> </tr> </tbody> </table> </div>	#	Value	Unit	Datatype	Server	Port	Register	1	HAir	m	Float	172.19.80.88	9000	0	+						
#	Value	Unit	Datatype	Server	Port	Register																
1	HAir	m	Float	172.19.80.88	9000	0																
+																						
#	Line number.																					
Value Unit Datatype	> Specify parameter, corresponding units and datatypes for selected line analog to the Modbus Slave settings																					
Register Server	> Enter register (for RTU) or server (for TCP)																					
ID Port	> Enter device / flowmeter identification number (Modbus RTU address) or Port number (Modbus TCP)																					
	↪ Click Apply to save settings.																					
Further transmission parameters for Modbus RTU protocol:																						
Datenbits:	8																					
Stop bits:	1																					
Parity:	none																					
Realized functions:	Read holding register: Function 03																					
<p>Please note: If no measurement values are available (e.g. in case of missing values due to sensor failure), the following values are exported to Modbus interface:</p> <ul style="list-style-type: none"> • Maximum value for "Float" data type - FLT_MAX = 3.4028234663852886e+38 • Maximum value for „LongInt" data type – LONG_MAX = 2147483647 • Maximum value for „Integer" data type – SHRT_MAX = 32767 																						
<p>Example: Request of a floating-point value</p> <p>The flowmeter device has the modbus adress 42 (ID: 42). In the user interface in register 1 the device is exporting the parameter water level (H), with current value 0.8351314 m (Register: 1, Value: H, Unit: m).</p> <p>Request (hexadecimal): 2A 03 00 00 00 02 C2 10</p> <table border="1" style="width: 100%; border-collapse: collapse;"> <thead> <tr> <th>Description</th> <th>Hexadecimal byte</th> <th>Remark</th> </tr> </thead> <tbody> <tr> <td>Address</td> <td>2A</td> <td>User settings 42</td> </tr> <tr> <td>Function</td> <td>03</td> <td>Read Holding Register</td> </tr> <tr> <td>Start adress high</td> <td>00</td> <td>Start adress 0</td> </tr> </tbody> </table>		Description	Hexadecimal byte	Remark	Address	2A	User settings 42	Function	03	Read Holding Register	Start adress high	00	Start adress 0									
Description	Hexadecimal byte	Remark																				
Address	2A	User settings 42																				
Function	03	Read Holding Register																				
Start adress high	00	Start adress 0																				

		(user settings Register 1)
Start adress low	00	
Number of values high	00	2 registers needed to represent a float
Number of values low	02	
Error check CRC	C2 10	

Answer (hexadecimal): 2A 03 04 CB 2C 3F 55 4F 13

Description	Hexadecimal	Remark
Address	2A	User settings 42
Function	03	Read Holding Register
Byte counter	04	
Data	CB 2C 3F 55	Value decimal = 0.8351314 Value Hex (IEEE 754 single precision) = 3F55CB2C
Error check CRC	4F 13	

7.9.4 SERIAL

Settings for communication via serial interface RS-232.

Communication

Network
FTP
MODBUS
Serial

Enable:

System key:

Device number:

Modus: AutoSend ▾

Baudrate: 9600 ▾

Send Frequency: 5 ▾

Protocol: Serial ▾

	Value:	Unit:
Value 1:	None ▾	▾
Value 2:	None ▾	▾
Value 3:	None ▾	▾
Value 4:	Q ▾	m³/s ▾
Value 5:	A ▾	m² ▾
Value 6:	None ▾	▾

Apply

▷ Serial

Setting	Description
Enable <input type="checkbox"/>	> <input checked="" type="checkbox"/> Tick checkbox to enable / disable serial communication.
System key	> Enter system key.
Device number:	> Enter serial number of device.
Modus ▼ Request Autosend	> Select the transfer mode.
Baudrate ▼ 115200 (...)	> Select desired baud rate from drop-down list.

1200	
Send Frequency ▼ 1, 5, (...), 60	> Select time span in seconds.
Protocol ▼ Serial C Type SHWP	> Select serial communication protocol type. Serial (Settings: baud rate 9600, parity: none; data bits: 8; stop bits 1) C Type Specific communication protocol corresponding to manufacturer specific data logger type. SHWP Specific communication protocol corresponding to manufacturer specific data logger type. Further specifications will be available on request.
Value ▼ A (...)	> Specify output parameter from drop-down list.
Unit	> Select desired unit for the value from drop-down list.
	🔗 Click Apply to save settings.

7.10 Diagnosis

- Home
- Graph
- Download
- Parameter
- I/O s
- Settings
- Communication
- Diagnosis
- Extras

► Diagnosis

▷ Log Files ▷ Data

7.10.1 LOG FILES

Diagnosis tool with display of log-files. The log-file contains the protocol with information, warnings and error messages of all operations the system has executed. It provides valuable information about possible errors in hardware and also errors resulting from incorrect operation by the user.

Settings for log-file history and display see in main menu ► Settings ▷ Logging (7.8.7).

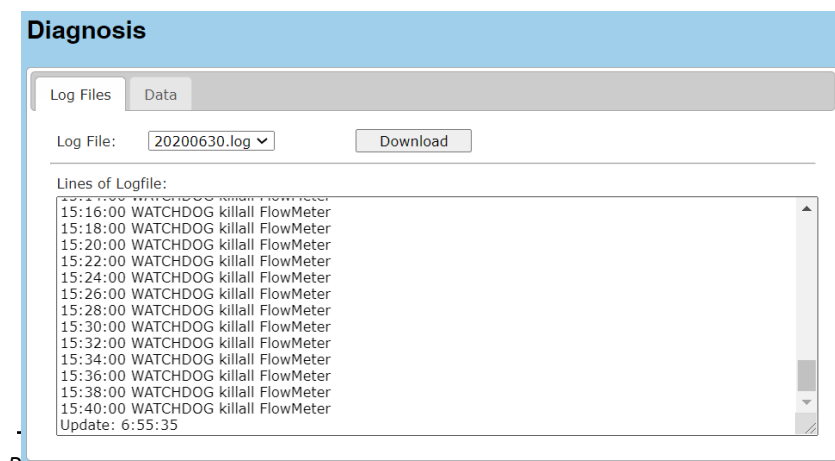

▷ Log Files

Setting	Description
Log File	> Select log-file from drop-down list. Filename: yyyyymmdd.log
	↳ Click Download to save file.

7.10.2 DATA

Display of parameter list with measured and computed values and corresponding units.
 Explanation of units and abbreviations see [chapter 7.12](#).

Diagnosis

Log Files
Data

Application buffer

Information	Value	SI - Unit	Base unit
<input type="button" value="read buffer"/>	<input type="button" value="create data-report"/>		

Flush application buffer

▷ Data

Application buffer	Measured and calculated values data are loaded in an internal software buffer (application buffer) for averaging. ↳ Click read buffer to display parameter list with measured and computed values (average values).
---------------------------	---

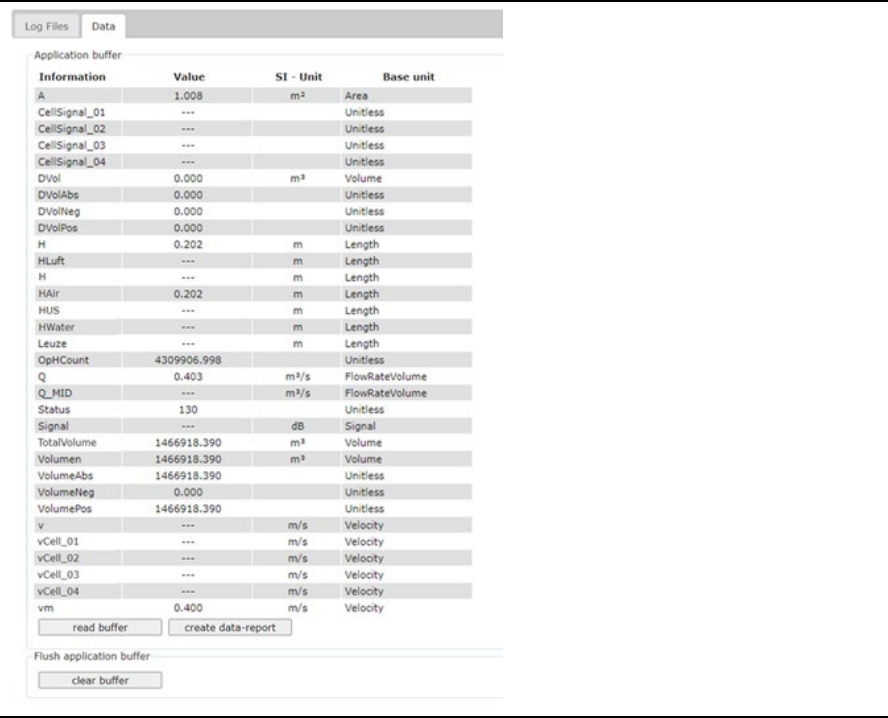
	
	<p>Click create data-report to open data file in text editor.</p>
<p>Flush application buffer</p>	<p>Click clear buffer to empty buffer and replace with most current data. After „flushing“ the internal buffer, averaging calculation starts with most current data.</p>

7.11 Extras

- Home
- Graph
- Download
- Parameter
- IO s
- Settings
- Communication
- Diagnosis
- Extras

► **Extras**

- ▷ Language Location ▷ Date Time ▷ LC-Display
- ▷ PowerManagement ▷ Backup & Update

7.11.1 LANGUAGE LOCATION

Language selection, site name entry field, settings for file, date, separator format.

Extras

Language Location
Date Time
LC-Display
PowerManagement
Backup & Update

Location

Site name:

Web-Interface

System language: English

Displayed language: German ▼

Decimals: 0 ▼

Download formatting

▷ Language Location

Setting	Description
Location	
Site name:	> Enter name of measuring site.
Web-Interface	
System language	English
Displayed language ▼ Spanish German Polish Japanese French Russian Czech	> Choose GUI display language. ↳ Click Apply to save settings. The corresponding flag symbol of the selected language will be displayed. ↳ Click the flag symbol to change between languages
Decimals	> Choose number of decimal places for display in web GUI.
Download formatting	
	<i>Download formatting is only possible for selectable download (see chapter 7.5.1). Direct and monthly download cannot be formatted by user.</i>
Data format	> Choose date format from drop-down list.
Date time separator	> Choose date and time separator from drop-down list.
Time format	> Choose time format from drop-down list.
Thousand separator	> <input checked="" type="checkbox"/> Tick checkbox to insert decimal separator.
Decimal separator	> Choose type decimal separator from drop-down list.
Filename extension	Define file format (*.txt or *.csv) from drop-down list. <i>Note that Excel might not open CSV files properly, e.g. all data are displayed in the first column due to different separators set in your Windows regional and language settings and the csv file.</i> For easy and correct import of measuring data in Excel, we recommend saving data as text file (*.txt). Opening a txt- file will start the text import wizard in Excel. The dialog window ensures correct data import by defining the delimiters e.g. for date, time.
	↳ Click Apply save settings.

7.11.2 DATE TIME

Settings for time and date and option for time synchronization via internet.

Time synchronization via NTP server can be activated to synchronize the system time of the measuring system or PC with other data bases or networks to enable identical time stamps.

INFORMATION!

Save all measurement data (see chapter 7.5.1) and log files (see chapter 7.10.1) before changing system time or date.

Otherwise, data could be deleted or overwritten. Measurement data and log files will be deleted if the last change to a file is too long in the past. The accepted time limit is 12 months for measurement data and 90 days for log files.

Extras

Language Location | **Date Time** | LC-Display | PowerManagement | Backup & Update

Current time
System time 09:25:29 2017-10-04

Date Time

Time manual
Time
Date

Internet time
NTP Server
Time zone UTC Universal Coordinated Time
automatic synchronization
synchronization interval 24

NTP time:
NTP date:

▷ Date Time

Setting	Description
Current time	
System time	> Display of current system time and date.
Date Time	
<input checked="" type="radio"/> Time manual	<p><input checked="" type="radio"/> Check radio button to set time and date manually. After checking the button, the current time and date are displayed.</p> <p>↳ Click on the respective input field to change the time and date. Time > Set desired time Date > Enter desired date</p>
	↳ Click Apply to save settings.
<input checked="" type="radio"/> Internet time	<p><input checked="" type="radio"/> Check radio button to activate time and date setting via NTP server (Network Time Protocol) Server. <i>NTP uses UTC (Coordinated Universal Time) for synchronization. In Germany MEZ (= CET) and MESZ (= CEST) is applied; CET = UTC + 1h and CEST = UTC + 2h</i></p>
NTP Server	> Enter IP address of desired NTP Server. <i>Many lists of IP addresses of NTV servers are available online.</i>
Time zone	> Select local time zone from drop-down list.
automatic Synchronization	> <input checked="" type="checkbox"/> Tick checkbox for automatic synchronization.
Synchronization interval	> Select desired interval for time synchronization from drop-down-list.
Test NTP connection	↳ Click test NTP Connection to check settings. NTP time & date are displayed.
	↳ Click Apply to save settings.

7.11.3 LC-DISPLAY

Definition for displayed parameters on 4-line display of transmitter (Line 1...Line 4).

4 parameters per LCD page can be displayed at once. Parameters can be selected individually from parameter list (*abbreviations see 7.12*). By adding additional LCD pages, further parameters can be displayed in intervals. Standard setting: 3 pages.

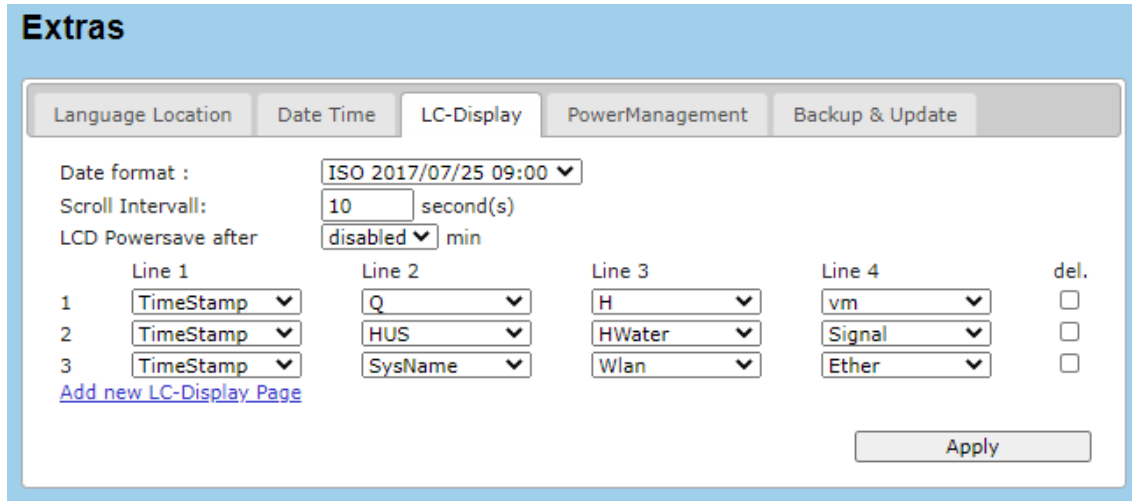

▷ LC-Display

Setting	Description
Date format	> Select data format. ISO: yyyy/mm/dd hh:mm US: mm/dd/yy hh:mm AM/PM
Scroll Interval	> Set time for scroll / display interval.
LCD Powersave after	> Set time for activation of power save modus for LC-Display. Or turn off the power saving mode by selecting disabled.
Line 1 – Line 4 ▼ TimeStamp Q (...)	> Select parameter to be displayed from drop-down list. (abbreviation of parameter names as listed in database)
del <input type="checkbox"/>	> <input checked="" type="checkbox"/> Tick checkbox to delete entries.
	↳ Click Apply to save settings.
Add new LC-Display Page	↳ Click on Add new LC Display Page to add new display page. Define the lines to be displayed on the new page (up to 4 lines). 
	↳ Click Apply to save settings.

7.11.4 POWER MANAGEMENT

Settings for power saving options during battery operation to save energy and to extend battery life.

Note, that during specified sleep time NO measurements and NO data processing are carried out.

Extras

Language Location | Date Time | LC-Display | **PowerManagement** | Backup & Update

Power cycle

Power saving mode:

Cycle time: 15 min

Saving: 10 %

Active time: 13.5 min

Sleep time: 1.5 min

Apply

▷ Power Management

Reboot system	Press to reboot system when using a remote connection to the device or instead of pressing the on/off button on the transmitter. Can be used in case of errors as a first method of troubleshooting. Does not restore factory settings. For factory reset, see chapter 8.2.2.
Power cycle	
Setting	Description
Power saving mode	> <input checked="" type="checkbox"/> Tick checkbox to activate the power saving mode.
Cycle time ▼ 15 (...)	> Select cycle time from drop-down list (max. 360 minutes). (Cycle time = Active Time + Sleep time)
Saving ▼ 10 (...)	> Select requested percentage energy saving during set cycle time (max. 90 %).
Active time	Display of calculated active time during set cycle duration.
Sleep time	Display of calculated sleep time during set cycle duration. <i>Always check sleep time settings with settings for FTP configuration under ► Communication ▷ FTP.</i>
	↵ Click Apply to save settings.

7.11.5 BACKUP & UPDATE

Function to save and upload data of hardware configuration and measurement parameters and software update option. For a software update Badger Meter will provide you with the specific update file (updatemt.tgz).

Always make sure to save your configuration and settings after initial commissioning of the device!

Extras

Language Location | Date Time | LC-Display | PowerManagement | **Backup & Update**

Configuration backup
Please backup your data.
Save:



Configuration restore
Load: Keine ausgewählt

Software update
Do not upload any files that were not created by Badger Meter for this unit!
Please select a file Keine ausgewählt

Update file:
File name:
File size:

▷ Backup & Update

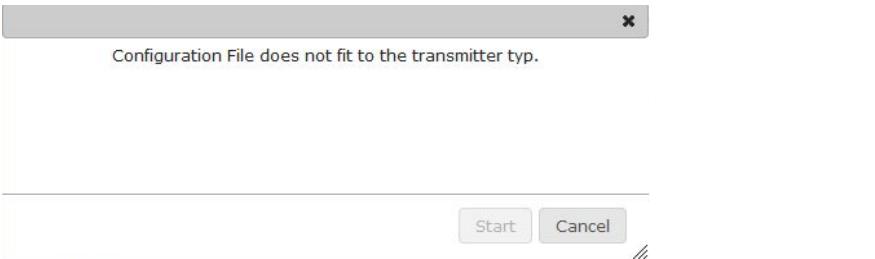
Setting	Description
Configuration backup	
Save	Click Backup to save configuration file in txt format.
Configuration restore	
Load	Click Browse... and select configuration file from your directory.
	Click Upload to load file to transmitter.
	<p>Click Start to restore configuration file.</p> <p><i>If the selected file does not correspond to the measuring system, the following error message is displayed.</i></p>

	
	<p>If the upload was successful, the system reboots. The device now reboots. Please login again in WebUI after reboot.</p> <p style="text-align: right;"></p> <p>Click OK to restart the system again.</p>
Software update	
<p>Badger Meter will provide you with the update file updatemt.tgz. Copy the file to your PC, Tablet etc.</p>	
<p><i>Always make sure to backup your data before starting an update. Only upload update files that are exclusively provided for your device by Badger Meter.</i></p>	
Please select a file	Click Browse... and select update file from your directory.
	Click Upload to load the file to the transmitter.
File name	Display of update file name.
File size	Display of update file size.
	<p>Click Update for software update. <i>Restart transmitter after successful software update.</i> > Press  <i>Reset / Restart key of transmitter</i></p>

7.12 Abbreviations

Note, that display of parameters may vary according to connected measuring system.

Parameter list under ► Diagnosis ▷ Data

Abbreviations	Explanation
A	cross section area of flow
Angle Radar	mounting (tilt) angle of radar velocity sensor RV24
DVol	daily volume (+/- signs included in summation)
DVolAbs	daily volume absolute (+/- signs not included in summation)
DVolNeg	daily volume negative (negative flow direction)
DVolPos	daily volume positive (positive flow direction)
H	water level, total
HAir	water level, measured with secondary external level sensor
HWater	water level, measured with primary external level sensor
OpHCount	operating time in hours
Q	discharge, flow
SNR	signal to noise ratio radar velocity sensor RV24
Status	status message of measuring system (0 = Status OK)
Signal	signal strength
TotalVolume	total volume
VolumeAbs	volume absolute – since last reset (+/- signs not included in summation)
VolumeNeg	volume negative (negative flow direction) – since last volume reset
VolumePos	volume positive (positive flow direction) – since last volume reset
vRadar	velocity of radar velocity sensor
vm	mean velocity of the entire cross section
Parameter list for Transmitter LCD display	
TimeStamp	current time
Wlan	active connection via WLAN
Ether	active connection via Ethernet / LAN
SysName	display of system name
Location	display of name of measuring site
CPUF	processor frequency
Text>	display text

8. SERVICE

8.1 Maintenance and care

WARNING

ALWAYS DISCONNECT POWER BEFORE DISMOUNTING OR CLEANING THE TRANSMITTER AND THE SENSORS. DO NOT USE ANY SHARP OR POINTED OBJECTS TO CLEAN THE SENSORS. BIOLOGICAL HAZARD. OBEY SAFETY REGULATIONS AND WEAR PERSONAL PROTECTIVE EQUIPMENT WHEN HANDLING A DEVICE THAT MAY HAVE COME IN CONTACT WITH BIOLOGICAL HAZARDOUS MATERIAL (E.G. WASTEWATER). WASH AND DECONTAMINATE THE DEVICES (TRANSMITTER, SENSORS) BEFORE MAINTENANCE OR SHIPPING.

If the flow meter is used properly, no special maintenance is required in normal operation. Nevertheless, check transmitter, sensors, cables and connections on visible dirt or deposits and damages. Remove possible coatings and deposits very carefully with a damp cloth and mild detergent.

8.2 Troubleshooting

8.2.1 ERROR CODES

Error code	Error message	Description	Error Handling
1	failure	General system failure	Contact Badger Meter
2	velocity	Failure velocity measurement	Check sensor and wiring
4	w water	Failure water level measurement with primary external level sensor (HWater)	Check sensor and wiring
8	w air	Failure water level measurement with secondary external level sensor (Hair)	Check sensor and wiring
16	t water	Failure water temperature measurement of an external connected temperature sensor	Check sensor and wiring
32	t air	Failure air temperature measurement of an external connected temperature sensor	Check sensor and wiring
64	water level	Failure ultrasonic water level measurement of area velocity sensor (only for systems Q-Eye PSC, Q-Eye PSC Portable)	Check sensor and wiring
128	v sensor communication timeout	Failure communication / connection to velocity sensor	Check sensor and wiring

Table 1: Error codes (depending on the configuration of the measuring system)

8.2.2 RESET TO FACTORY SETTINGS

A total system failure might be caused by loss of the params.txt-file.

To resolve the failure reset the transmitter to default parameters (factory settings) by the following steps:

- ① Error message transmitter display:

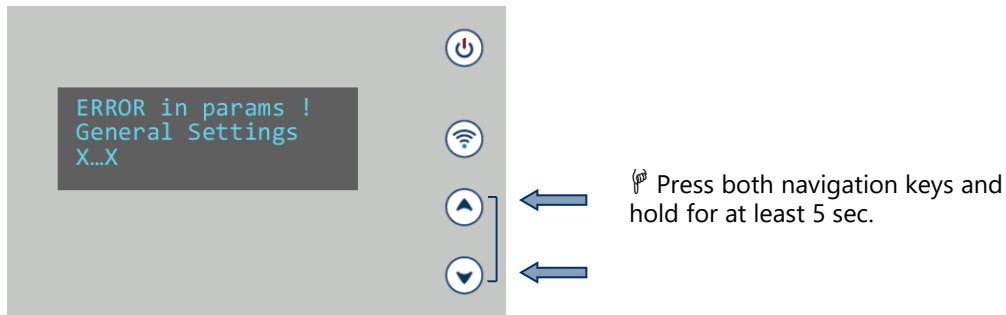

- ② Hold until the following message is displayed. Release buttons. Then press „up“ button within the next 5 seconds.

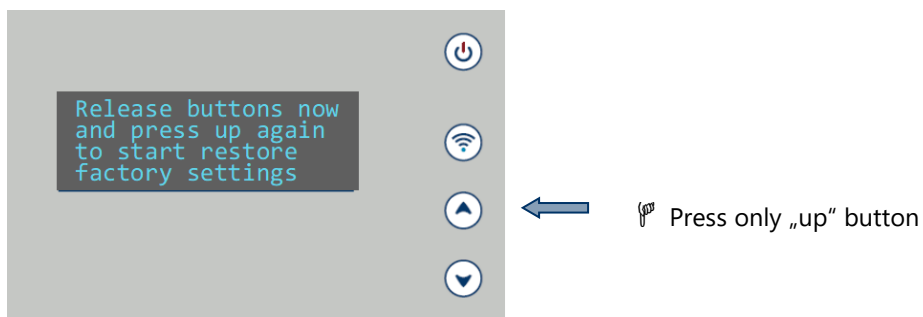

- ③ The system starts to restore the factory settings...

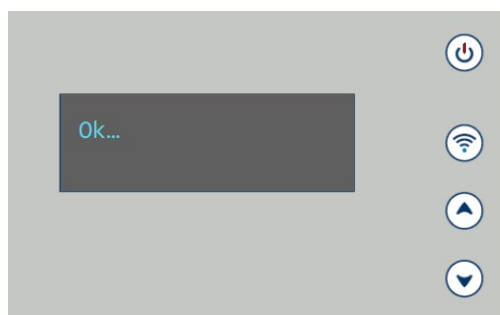

- ④ ... and reboots and the system starts measurements again

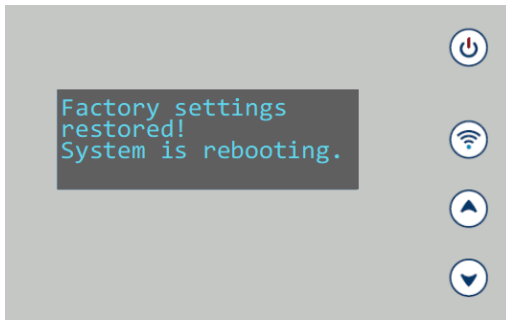

- ⑤ After successful rebooting, it is now possible to upload the user-defined params.txt-file.

Therefore, change to GUI and go to ► Extras ▷ Backup & Update:

Extras

Language Location
Date Time
LC-Display
PowerManagement
Backup & Update

Configuration backup

Please backup your data.

Save:

Configuration restore

Load: Keine ausgewählt

Software update

Do not upload any files that were not created by Badger Meter for this unit!

Please select a file Keine ausgewählt

Update file:

File name:

File size:

Configuration restore

👉 Click **Browse..** and select configuration file from your directory.

👉 Click **Upload** to load file to transmitter.

👉 Click **Start** to restore configuration file.

For further information see [chapter 7.11.5](#).

Now press Reset / Restart button of transmitter to restart again and to activate changed settings.

8.3 Technical support

Please have the following information and details ready when calling our technical support:

- Brief description of fault, error, failure
- Error code shown on display or in web interface
- Device specifications, e.g. serial number (see nameplate) Return / Repair

8.4 Return / Repair

Please follow the following instructions in case the device has to be returned to Badger Meter for repair or inspection.

For returning the device proceed as follows:

- Fill in one sheet per returned instrument. This will help us to get the information needed to carry out the repair as soon as possible.
- Include the completed and signed IFR with your return shipment.
- Clean and decontaminate the device properly.
- Pack it safely by ideally using the original packing.
- Send the parcel to Badger Meter Europa GmbH for repair

NOTICE!

Keep original packaging for safe storage and safe transport.

CAUTION

DECONTAMINATION NOTE

BECAUSE OF LEGAL REGULATIONS ON ENVIRONMENTAL PROTECTION AND FOR THE SAFETY AND HEALTH OF OUR EMPLOYEES, ONLY SEND BACK CLEAN AND DECONTAMINATED DEVICES.

IF THE DEVICE HAS BEEN OPERATED WITH TOXIC, FLAMMABLE OR WATER-ENDANGERING PRODUCTS CHECK AND ENSURE, IF NECESSARY, BY RINSING OR NEUTRALISING, THAT ALL CAVITIES ARE FREE FROM SUCH DANGEROUS SUBSTANCES.

THE MANUFACTURER RESERVES THE RIGHT TO REFUSE THE DELIVERY OF DIRTY OR CONTAMINATED DEVICES OR, IF NECESSARY, CHARGE EXTRA CLEANING COSTS.

SIGN THE IRF (INSTRUMENT RETURN FORM) TO CONFIRM THAT THE DEVICE IS SAFE TO HANDLE.

8.5 Disposal

WARNING

DISCONNECT POWER BEFORE DISMOUNTING THE DEVICE.

RISK OF POTENTIAL HAZARD TO HUMANS AND ENVIRONMENT DUE TO HARMFUL SUBSTANCES.

ENSURE, THAT THE DEVICE AND SENSORS ARE FREE FROM HARMFUL SUBSTANCES.

IMPORTANT

Dispose the device in compliance with your country's legal and valid regulations for the disposal of electronic and electrical appliances. Correct disposal avoids negative effects on public health and the environment and ensures recycling of useful raw materials.



This symbol indicates that the directive 2009/96 EG on waste and electronic equipment requirements shall be observed on the disposal of the device.

9. OPERATING PRINCIPLE

9.1 Non-contact surface velocity measurement (pulse wave radar velocity)

The radar velocity sensor is operating at the free 24 GHz band frequency and makes use of the Doppler effect to produce velocity data of the moving surface. It does this by beaming a microwave signal to the water surface at a defined angle and by recording its reflection on moving particles or bubbles on the surface moving with the flow. The frequency of these reflecting signals has been shifted by an amount directly proportional to the velocity of the moving surface. The frequency shift and analysis are performed by means of a Fast Fourier transform (FFT). The velocity is calculated based on knowledge of the radar frequency, speed of light and average frequency shift.

9.2 Measurement spot

The size of measurement spot of the radar velocity sensor depends on the distance of the radar sensor to the water surface and the mounting angle. In the following tables the dimensions of the measurement spot of the radar velocity sensors are listed depending on different mounting angles (60°, 45° and 30°):

RV 11 Dimensions of measurement spot						
Opening angle : 11°						
	mounting angle 45°			mounting angle 30°		
Distance to water surface	Distance to middle of spot	W_{Spot} [m]	L_{Spot} [m]	Distance to middle of spot	W_{Spot} [m]	L_{Spot} [m]
0,100	0,141	0,019	0,039	0,200	0,019	0,079
0,200	0,283	0,039	0,078	0,400	0,039	0,158
0,300	0,424	0,058	0,117	0,600	0,058	0,238
0,400	0,566	0,077	0,156	0,800	0,077	0,317
0,500	0,707	0,096	0,194	1,000	0,096	0,396
0,600	0,849	0,116	0,233	1,200	0,116	0,475
0,700	0,990	0,135	0,272	1,400	0,135	0,555
0,800	1,131	0,154	0,311	1,600	0,154	0,634
0,900	1,273	0,173	0,350	1,800	0,173	0,713
1,000	1,414	0,193	0,389	2,000	0,193	0,792
1,100	1,556	0,212	0,428	2,200	0,212	0,872
1,200	1,697	0,231	0,467	2,400	0,231	0,951
1,300	1,839	0,250	0,506	2,600	0,250	1,030
1,400	1,980	0,270	0,544	2,800	0,270	1,109
1,500	2,121	0,289	0,583	3,000	0,289	1,189
1,600	2,263	0,308	0,622	3,200	0,308	1,268
1,700	2,404	0,327	0,661	3,400	0,327	1,347
1,800	2,546	0,347	0,700	3,600	0,347	1,426
1,900	2,687	0,366	0,739	3,800	0,366	1,505
2,000	2,828	0,385	0,778	4,000	0,385	1,585
2,500	3,536	0,481	0,972	5,000	0,481	1,981
3,000	4,243	0,578	1,166	6,000	0,578	2,377
4,000	5,657	0,770	1,555	8,000	0,770	3,169
5,000	7,071	0,963	1,944	10,000	0,963	3,962
6,000	8,485	1,155	2,333	12,000	1,155	4,754
7,000	9,899	1,348	2,721	14,000	1,348	5,546
8,000	11,314	1,541	3,110	16,000	1,541	6,339
9,000	12,728	1,733	3,499	18,000	1,733	7,131
10,000	14,142	1,926	3,888	20,000	1,926	7,924

Table 2: Dimensions of measurement spot of radar velocity sensor RV11

Height (H) [m]	Distance (L) [m]	Angle 30° D1xD2 [m]	Distance (L) [m]	Angle 45° D1xD2 [m]
0,5	0,9	1,0 x 0,3	0,5	0,5 x 0,3
1	1,7	2,0 x 0,4	1,0	0,9 x 0,3
2	3,5	3,9 x 0,8	2,0	1,8 x 0,6
3	5,2	5,9 x 1,3	3,0	2,7 x 0,9
4	6,9	7,9 x 1,7	4,0	3,6 x 1,2
5	8,7	9,8 x 2,1	5,0	4,5 x 1,5
6	10,4	11,8 x 2x5	6,0	5,3 x 1,8
7	12,1	13,8 x 2,9	7,0	6,2 x 2,1
8	13,9	15,7 x 3,4	8,0	7,1 x 2,4
9	15,6	17,7 x 3,8	9,0	8,0 x 2,7
10	17,3	19,7 x 4,2	10,0	8,9 x 3,0
12,5	21,7	24,6 x 5,3	12,5	11,1 x 3,7
15	26,0	29,5 x 6,3	15,0	13,4 x 4,5
17,5	30,3	34,4 x 7,4	17,5	15,6 x 5,2
20	34,6	39,3 x 8,4	20,0	17,8 x 5,9

Table 3: Dimensions of the measurement spot of radar velocity sensor RV24

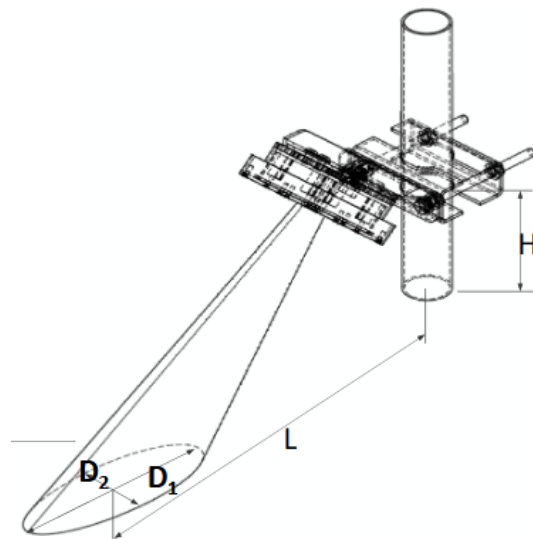

10. TECHNICAL DATA

10.1 Transmitter

Transmitter	
Display	LC-Display, 4 lines, 20 characters
Keyboard	4 keys
Communication:	RS-485, WiFi, MODBUS (RS232, RS485), Ethernet 10/100 Mbps
Mobile Communication (Optional)	4G (LTE) / 3G (HSPA+), 2G modem Frequency: 800 – 2600 MHz, Max. Power (EIRP): 23 dBm
Datalogger / memory:	16 GB Micro SD card
Power Supply:	100 -240 VAC, ±10% 47-63Hz or 9-36 VDC, ±15%, 5% residual ripple
Inputs:	max. 4 x 4 - 20 mA analog input channels 2x digital
Outputs:	max. 4 x 4-20 mA analog output channels 4x Relay, 2x digital Relay output (Frequency 0- 200Hz): AC: 30 Vrms 1A DC: 60 V 1A (pure ohmic load)
Operating temperature	-4...140° F (-20...60° C)
Operating conditions:	protection class I overvoltage category II pollution degree 2
Maximum Humidity	90% (non-condensing)
Enclosure: (Wall mounted)	
IP classification:	IP 66 EN 60529 (NEMA 4)
Enclosure material:	Aluminium alloy DIN EN 573 EN AW-ALMgSi Terminal enclosure: Aluminium alloy DIN EN 1706 EN AC-AISI 12 (Fe)
Dimensions:	270 x 139 x 256 mm (LxWxH)

10.2 Non-contact radar velocity sensor RV11

	Non-contact radar velocity sensor
Main application:	wastewater
Measuring principle:	bidirectional microwave velocity measurement
Frequency (radar):	24 GHz
Beam width:	11° (-3dB)
Range:	± 0.05 m/s to ± 15.0 m/s
Resolution:	1 mm/s
Min. wave height:	3 mm
Uncertainty velocity:	±0.5% Full Scale
Uncertainty flow:	typically < 5% of reading, depending on site conditions
Min. distance sensor/fluid:	0.2 m
Max. distance sensor/fluid:	10 m
Operating temperature:	-40...85° C
Power consumption:	Max. 200 mA
Materials:	POM polyoxymethylene plastic (front and side) anodized aluminium (rear side) stainless steel (connections)
Protection class:	IP68 (48 h at 50 kPa, NEMA 6P)
Dimensions:	242 mm (L incl. mounting bracket), 100 × 100 (W × H sensor)

10.3 Non-contact radar velocity sensor RV24

	Non-contact radar velocity sensor
Main application:	hydrology
Measuring principle:	bidirectional microwave velocity measurement
Frequency (radar):	24 GHz
Beam width:	12° azimuth, 24° elevation
Range:	± 0.02 m/s to ± 15.0 m/s
Resolution:	1 mm/s
Min. wave height:	1 mm
Uncertainty velocity:	± 1% of measured value
Uncertainty flow:	typically < 3% of measured value after calibration
Min. distance sensor/fluid:	0.5 m
Max. distance sensor/fluid:	50 m (radar beam to water) 20 m (height above water)
Operating temperature:	IP 68
Dimensions:	110 x 90 x 50 mm (H x W x D)

10.4 Ultrasonic and radar water level sensors

	Ultrasonic water level sensors		
Type:	WLU3902	WLU3802	WLU3702
Measuring principle:	Transit time measurement		
Frequency:	80 kHz	80 kHz	60kHz
Beam angle:	6°	5°	7°
Range:	0.2 to 4 m	0.25 to 6 m	0.35 to 8 m
Uncertainty:	± (0.2% of measured distance plus 0.05% of range)		
Output:	4-20 mA, 2-wire		
Operating temperature:	-25°C to +70°C		
Power supply:	24 VDC (20 – 28 VDC)		
Dimensions:	<i>(see Fig. 6)</i>		
Sensor material:	PP, PVDF or PTFE		
Housing material:	Plastic / Aluminium		
Protection class:	Sensor: IP 68, Housing: IP 67		
Mounting:	1½" BSP/NPT	2" BSP/NPT5°	2" BSP/NPT
Cable			
2xM20x1.5 cable glands +internal thread for 2x 1/2 'NPT protective pipe			
Outside Diameter:	Ø6 mm - Ø12 mm		

	Radar water level sensors		
Type:	WLR1108	WLR2115	WLR2330
Measuring principle:	Transit time measurement of short radar pulses		
Frequency:	W-band (80 GHz technology)		
Beam angle:	8°	8°	4°
Range:	0 to 8 m	0 to 15 m	0 to 30 m
Uncertainty:	± 5 mm	± 2 mm	± 2 mm
Output:	2-wire, 4-20 mA	2-wire, 4-20 mA	2-wire, 4-20 mA
Threaded connection	G 1½ process side G1 cable side	G 1½ process side G1 cable side	G1 cable side
Operating temperature:	-40°C - 60°C	-40°C - 80°C	-40°C - 80°C
Dimensions:	length: 109 mm, diameter: 68 mm	length: 109 mm, diameter: 68 mm	length: 130 mm, diameter: 76 mm
Housing material:	PVDF, FKM seal	PVDF, FKM seal	PVDF
Protection class:	IP 66 / IP 68 (3 bar)	IP 66 / IP 68 (3 bar)	IP 66 / IP 68 (3 bar)
ATEX option:	No	II 1G, 1/2G Ex ia IIC T4 Ga, Ga/Gb	II 1G, 1/2G Ex ia IIC T4 Ga, Ga/Gb
Mounting:	Mounting bracket for wall or ceiling installation		
Cable			
Length:	10 m	5, 10 or 25 m	5, 10 or 25 m
Material	PVC	PUR	PUR

11. ANNEX

11.1 Roughness coefficients

Manning's equation roughness coefficients for various channel materials

The Manning's equation is an empirical formula for open channel flow. Function of velocity, flow area, channel slope and roughness.

$$Q = vA \text{ with } v = k_{st} R_h^{2/3} I_c^{1/2}$$

Q:	Discharge
v:	Flow velocity
A:	Cross sectional area
k_{st} :	Roughness coefficient (Strickler)
$R_h^{2/3}$:	Hydraulic radius (cross sectional A / wetted perimeter P)
$I_c^{1/2}$:	Channel downward slope

Empirical roughness coefficients are listed in sets of tables (*see below*). The following symbols are used:

k_{st} = Strickler coefficient (more known in Europe)

n = Manning Coefficient

$$k_{st} [m^{1/3}/s] = 1/n$$

		Manning Coeff.			Strickler Coeff.
		n min	n Norm	n max	k _{st}
Material					
I Closed conduit - partly full					
A. Metal					
1. Steel	a. Lockbar and welded	0.010	0.012	0.014	83
	b. Riveted and spiral	0.013	0.016	0.017	63
2. Cast Iron	a. Coated	0.010	0.013	0.014	77
	b. Uncoated	0.011	0.014	0.016	71
3. Wrought Iron	a. Black	0.012	0.014	0.015	71
	b. Galvanized				
4. Corrugated	a. Subdrain	0.017	0.019	0.021	53
	b. Storm Drain	0.021	0.024	0.030	42
B. Nonmetal					
1. Synthetics/ plastics					
	a. Acryl	0.008	0.009	0.010	111
*	b. Polyethylene (PE)	0.008	0.009	0.011	111
*	c. Corrugated Polyethylene Culvert Pipe (smooth)	0.009	0.013	0.015	77
*	d. Corrugated Polyethylene Culvert Pipe (corrugated)	0.018	0.023	0.025	43
*	e. Polyvinyl chloride (PVC)	0.009	0.010	0.011	100

Material		Manning Coeff.			Strickler Coeff.	
		n _{min}	n _{Norm}	n _{max}	k _{st}	
	2. Glass		0.009	0.010	0.013	100
	3. Wood					
		a. Stave	0.010	0.012	0.014	83
		b. Laminated, treated	0.015	0.017	0.020	59
	4. Clay					
		a. Common drainage tile	0.011	0.013	0.017	77
		b. Vitrified sewer	0.011	0.014	0.017	71
		c. Vitrified sewer with manholes, inlets, etc.	0.013	0.015	0.017	67
	5. Brick					
		a. Glazed	0.011	0.013	0.015	77
		b. Lined with cement	0.012	0.015	0.017	67
	6. Concrete					
		a. Culvert, straight and free of debris	0.010	0.011	0.013	100
		b. Culvert with bends, connections and some debris	0.011	0.013	0.017	77
		c. Sewer with manholes, inlet, etc., straight	0.013	0.015	0.017	67
		d. Unfinished, steel form	0.012	0.013	0.014	83
		e. Unfinished, smooth wood form	0.012	0.014	0.016	83
		f. Unfinished, rough wood form	0.015	0.017	0.020	59
	7. Sanitary sewers coated with sewage slimes		0.012	0.013	0.016	77
	8. Paved invert, sewer, smooth bottom		0.016	0.019	0.020	53
	9. Rubble masonry, cemented		0.018	0.025	0.030	40
II. Lined or built-up channels						
A. Metal						
	1. Smooth steel surface					
		a. Painted	0.011	0.012	0.014	83
		b. Unpainted	0.012	0.013	0.017	77
	2. Corrugated		0.021	0.025	0.030	40
B. Non Metal						
	1. Cement					
		a. Neat surface	0.010	0.011	0.013	91
		b. Mortar	0.011	0.013	0.015	77
	2. Concrete					
		a. Trowel finish	0.011	0.013	0.015	77
		b. Float finish	0.013	0.015	0.016	67
		c. Finished, with gravel on bottom	0.013	0.017	0.020	59
		d. Unfinished	0.014	0.017	0.020	59
	3. Wood					
	a. Planed, untreated	0.01	0.012	0.014	83	

Material		Manning Coeff.			Strickler Coeff.	
		n_{min}	n_{Norm}	n_{max}	k_{st}	
		b. Planed, creosoted	0.011	0.012	0.015	83
		c. Unplaned	0.011	0.013	0.015	77
		d. Plank with battens	0.012	0.015	0.018	67
		e. Glazed	0.011	0.013	0.015	77
		f. In cement mortar	0.012	0.015	0.018	67
	4. Masonry					
		a. Cemented rubble	0.017	0.025	0.030	40
		b. Dry rubble	0.023	0.032	0.035	31
	5. Asphalt					
		a. Smooth	0.013	0.013	-	77
		b. Rough	0.016	0.016	-	63
	6. Vegetal lining		0.030	-	0.500	
III. Excavated or dredged						
	A. Earth, straight and uniform		0.016	0.022	0.035	29
	B. Earth, winding and sluggish		0.023	0.030	0.040	25
	C. Rock cuts		0.030	0.040	0.040	25
	D. Unmaintained channels		0.040	0.070	0.140	7
IV. Natural channels						
	A. Fairly regular section		0.030	0.050	0.070	20
	B. Irregular section with pools		0.040	0.070	0.100	14
From: Isco Open Channel Flow Measurement Handbook & *CeCalc.com - Civil Engineering Calculations [2]						

11.2 Bibliography

[1] DIN 4263 (2011): Kennzahlen von Abwasserkanälen und -leitungen für die hydraulische Berechnung im Wasserwesen, Beuth Verlag GmbH, Berlin, 9 S.

[2] ISO 748:2007: Hydrometry - Measurement of liquid flow in open channels using currentmeters or floats (ISO 748:2007); German version EN ISO 748:2007.

[3] Grant, Douglas M., Dawson, Brian D. (2001): Isco Open Channel Flow Measurement Handbook, 5th edition; Isco Inc. Lincoln, Nebraska, USA

Control. Manage. Optimize.

Dynasonics, AquaCUE and SoloCUE are registered trademarks of Badger Meter, Inc. Other trademarks appearing in this document are the property of their respective entities. Due to continuous research, product improvements and enhancements, Badger Meter reserves the right to change product or system specifications without notice, except to the extent an outstanding contractual obligation exists. © 2021 Badger Meter, Inc. All rights reserved.

www.badgermeter.com

Control. Manage. Optimize.

Dynasonics, AquaCUE and SoloCUE are registered trademarks of Badger Meter, Inc. Other trademarks appearing in this document are the property of their respective entities. Due to continuous research, product improvements and enhancements, Badger Meter reserves the right to change product or system specifications without notice, except to the extent an outstanding contractual obligation exists. © 2021 Badger Meter, Inc. All rights reserved.

www.badgermeter.com