

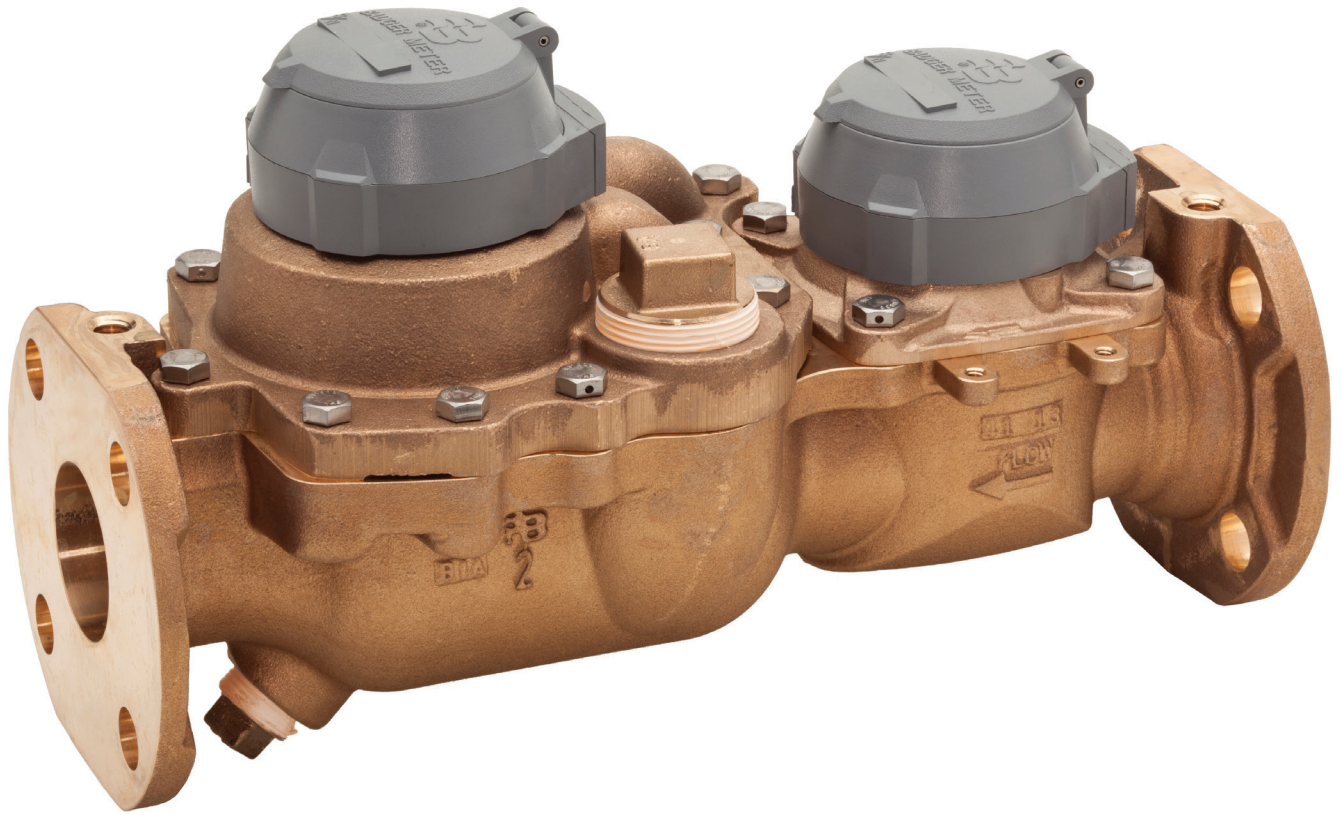

Badger Meter

Recordall® Compound Series Meter

**Lead-Free Bronze Alloy, Sizes 2, 3, 4 & 6 inch
NSF/ANSI Standards 61 and 372 Certified**



CONTENTS

Scope of This Manual	3
Product Information	3
Installation.	4
Preinstallation Considerations	4
Installing the Meter	5
Checking Performance	6
Reading the Recordall Registers (and Encoder).	6
Maintenance	6
Accuracy Testing	6
Maintenance Equipment.	7
Preventive Maintenance	7
Servicing Parts and Assemblies.	8
Removing the High Flow Turbo Meter Head Assembly	8
Removing the Turbo Measuring Element Assembly from the Cover Plate	10
Removing the Magnet Carrier/Top Gear Set	10
Removing the Straightening Vanes/Nose Cone	10
Removing the Calibration Mechanism.	10
Inspecting the Rotor and Bearings	12
Removing the Rear Nose Cone	13
Reinstalling the High Flow Turbo Meter Head Assembly	13
Removing the Low Flow Side	14
Servicing the Chamber and Disc	14
Valve Assembly	15
Removing the Valve Assembly.	15
Replacing the Valve Assembly	15
Reinstalling the Cover Assembly	15
Specifications	16

SCOPE OF THIS MANUAL

This manual contains installation, operation and maintenance procedures for the Badger Meter® Recordall® Compound Series meters with magnetic drives.

PRODUCT INFORMATION

Product Description

The Compound Series meters combine two metering technologies in one package. A positive displacement chamber measures low flow, while a turbine chamber records high flow. The compound meters are available in 2 inch, 3 inch, 4 inch and 6 inch sizes.

A spring-loaded valve assembly controls the flow through each of the two measuring elements to provide maximum accuracy and performance.

The basic components of the compound meter are the housing, and the Turbo Series head assembly and cover assembly with disc chamber assembly. The head assembly includes a Recordall register or encoder for high flow totalization and complete turbo head components (cage and rotor). The cover assembly includes a Recordall register or encoder for low flow totalization and a complete chamber assembly.

The output of both measuring elements, the disc and turbo, is transmitted to each Recordall register or encoder by means of ceramic magnets. The register or encoder is permanently sealed in a controlled environment relative to humidity and cleanliness, thus assuring longevity of performance.

Related Literature

- The *Recordall Compound Series Meters Product Data Sheet* contains information on operating principle, meter construction, materials, tolerances and specifications.
- The *Recordall Compound Series Meters Parts List* contains part numbers, part descriptions and illustrations.

Safety Information

The installation of the Recordall Compound Series meter must comply with all applicable federal, state, and local rules, regulations, and codes.

Failure to read and follow these instructions can lead to misapplication or misuse of the meter, resulting in personal injury and damage to equipment.

Unpacking and Inspection

To avoid damage in transit, Recordall Compound Series meters are shipped to the customer in special shipping containers. Upon receipt of shipment, be sure to follow these unpacking and inspection procedures:

- NOTE:** If damage to a shipping container is evident upon receipt of a meter, request that a representative of the carrier be present when the meter is unpacked.
- a. Carefully open the shipping container, following any instructions that may be marked on the container. Remove all cushioning material surrounding the meter and carefully lift the meter from the container. Keep the container and all packing material for possible use in reshipment or storage.
 - b. Visually inspect the meter and applicable accessory devices for any signs of damage such as scratches, loose or broken parts or other physical damage that may have occurred during shipment.

NOTE: If damage is found, request an inspection by carrier's agent within 48 hours of delivery. Then file a claim with the carrier. A claim for equipment damaged in transit is the responsibility of the customer.

INSTALLATION

Procedures for installing Recordall Compound Series meters are essentially the same for all meter sizes. Any special instructions required for the installation or connection of accessory devices such as AMR/AMI technologies or strainers is provided in the literature for those devices. *Figure 1* shows a recommended meter installation.

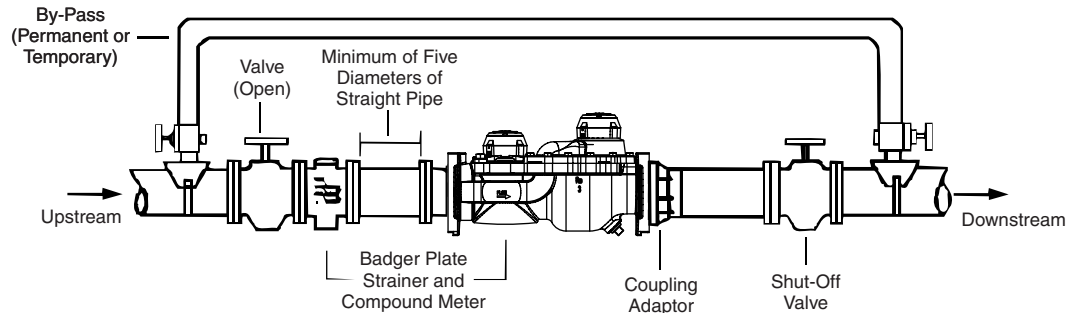

Figure 1: Recommended meter installation

Preinstallation Considerations

Take the following considerations into account before proceeding with the installation.

NOTE: The Recordall Compound Series meters are designed for operation in HORIZONTAL piping arrangements.

- Be sure that the meter flow range and size of the meter coincide with the intended service and demand for water.

CAUTION

THE LIFE OF THE COMPOUND METER WILL BE CURTAILED IF OPERATED AT FLOW RATES HIGHER THAN SPECIFIED.

- The meters are designed for use in cold water service (up to 120° F or 27° C) within the applicable flow requirements for compound meters. For use with water at higher temperatures, consult your Badger Meter representative.
- If solid material is present in the water to be metered, a strainer must be installed in the service piping upstream of the meter. In addition to protecting the meter from debris in the line, the strainer minimizes the effect of velocity profile distortions or turbulence caused by changes in pipe direction or valving resulting in more accurate registration.
- Avoid installing the meter in tight spaces. Allow sufficient space to permit access for meter reading, testing, and maintenance.
- Because of the need to test large meters periodically to verify their performance, it is recommended that a bypass system be incorporated into the piping arrangement. This will also provide a means of performing periodic cleanout and routine maintenance without interrupting service to the customer. A test port is incorporated in the meter housing and can be used for field accuracy testing.
- The Recordall Compound Series meter is accuracy and pressure tested prior to shipment, therefore no field adjustments are required. As turbine performance is directly related to the flow conditions of the water stream entering the meter, upstream fittings and piping changes can adversely affect flow registration. For valid registration and proper performance, consider the following installation considerations:
 - ◇ When installing the meter with a Badger Meter Plate Strainer, a minimum of 5 pipe diameters of straight, unobstructed pipe is required upstream of the meter. (A minimum of 10 pipe diameters of straight unobstructed pipe is required upstream of a meter installed without a plate strainer. The deletion of a strainer, however, is not recommended.) This allows for dampening of velocity profile distortions caused by items such as elbows, pumps and dirt traps upstream of the meter. Where spiral flows are created by three dimensional elbows or rotary pumps, use additional distance to dampen the effect. If a basket or Y-type strainer is used, place it 5 to 10 pipe diameters upstream of the meter to dampen velocity profile distortions created by this design.
 - ◇ Do not install check valves or pressure reducing devices upstream of the meter.

- ◇ Valves immediately upstream of the meter should only be fully-open gate valves. Butterfly valves are acceptable if they are 5 pipe diameters or more upstream from the meter. Downstream, fully open gate or butterfly valves can be used.
- ◇ Unweighted check valves should not be located closer than 3 pipe diameters downstream of the meter.
- ◇ Externally weighted check valves and pressure reducing devices should not be located closer than 5 pipe diameters of the meter.
- ◇ When installing a compound meter and plate strainer of a size smaller than the pipe installation, to reduce the effect of jetting caused by the increase in flow velocity, a minimum of 5 pipe diameters of pipe equal in size to the meter, is required upstream of the meter. Additional length is required if a sharp contraction or an eccentric reducer, rather than a concentric, tapered reducer is used.

Installing the Meter

CAUTION

- **DO NOT ATTEMPT TO USE ANY METER AS A LEVER OR CROWBAR TO STRAIGHTEN A MISALIGNED METER POSITION. THIS COULD DAMAGE THE METER.**
- **TO AVOID POTENTIAL PROBLEMS, CORRECT ANY IRREGULARITIES IN PIPE SPACING AND MISALIGNMENT BEFORE PLACING THE METER INTO ITS POSITION.**

Overall dimensions and laying lengths of each meter size are listed in the *Recordall Compound Series Meter Product Data Sheet*. Review the dimensional requirements, choose an installation point in the piping, and proceed as follows:

1. Measure precisely the overall length of the meter with gaskets attached to the inlet and outlet flange connections.
2. Provide proper gap length in service piping.
3. Install meter in the pipeline so that the flow arrow on the meter housing points in the direction water flows.
4. With meter and gaskets in place, tighten flange connection bolts. A cross star torque pattern is recommended.
5. To relieve possible strain on the piping, position a meter support under the meter housing where appropriate.

Adapter Spacers

The 2 inch and 4 inch Compound Series meters are supplied in 15-1/4 inch and 20 inch lay lengths, respectively. If you have an existing compound meter with a lay length of 17 inches for the 2 inch size, or 24 inches for the 4 inch size, a Flange Adapter Kit is available for each to accommodate the difference. Mount the Flange Adapter to the outlet side of the meter.



Figure 2: 2 in. adapter



Figure 3: 2 in. adapter with 2 in. elliptical meter



Figure 4: 2 in. adapter with 2 in. round meter



Figure 5: 4 in. adapter



Figure 6: 4 in. adapter with 4 in. meter

Description	Part Number
2 in. Elliptical Flange Adapter Kit	64186-001
2 in. Round Flange Adapter Kit	64186-002
4 in. Flange Adapter Kit	64186-003

CAUTION

COMPOUND METERS MUST OPERATE IN A COMPLETELY FILLED LINE AT ALL TIMES. THE DOWNSTREAM PIPING MUST BE ARRANGED TO PROVIDE SUFFICIENT BACK PRESSURE TO MAINTAIN A FULL LINE AT THE METER. BY ELIMINATING AIR IN THE LINE, AS WELL AS SUDDEN FLOW SURGES, INACCURATE REGISTRATION AND DAMAGE TO THE TURBINE MECHANISM CAN BE AVOIDED.

Checking Performance

Any valves or devices controlling the flow of water through a compound meter must always be opened and closed SLOWLY to prevent shock loads that may damage the meter rotor assembly. Complete the following checks to make sure the meter is properly installed and operational:

- Slowly open the upstream valve to apply water pressure to the meter. Check to see if there are any leaks. Tighten the flange bolts as required.
- Perform a functional test of the meter. Slowly open the valve on the downstream side of the meter to evacuate any air that may be trapped in the service line. When air has been eliminated, increase the demand flow rate by further opening the downstream valve or valves. Observe the register for correct direction of flow. Continue to open the demand side valves to a flow rate sufficient to open the valve assembly in the meter—a procedure which will start water flowing through the turbo high-side rotor. The high flow pointer will now move in the proper direction. Now open all applicable service valves.
- Check the flow rate to verify that the flow does not exceed the maximum continuous duty specification. The rate of flow can be quickly checked by timing the quantity registered through the meter in one minute.

Reading the Recordall Registers (and Encoder)

To determine the total reading for the meter, add the totals for the low and high flow.

1. Determine the low flow total by reading the register/encoder identified as low flow. Read only the moveable number wheels.
2. From the high flow register, read both the number wheels and the sweep hand. Read the number wheels first. Read only the moveable number wheels. Note the position of the sweep hand, round the number down to the nearest increment. Add the reading from the number wheel and the sweep hand together.
3. To determine the complete total flow, add the low flow and high flow totals together.

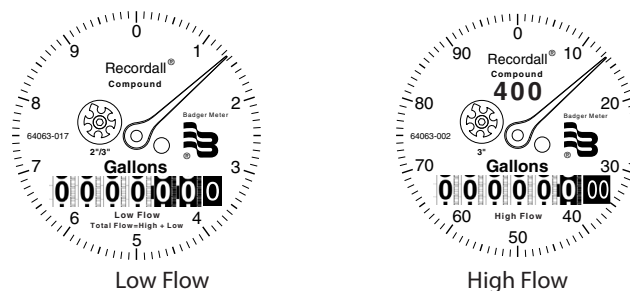

Figure 7: Reading the register example

MAINTENANCE

This section includes general maintenance information for the Recordall Compound Series meters.

Accuracy Testing

The meter can be tested for accuracy with a test meter or a test tank of known volume. A test plug is provided on the meter. The low flow register is for recording the amount of water passing through the disc, or low flow side of the meter. The high flow register is for recording the amount of water passing through the turbo, or high flow side of the meter.

Testing Below Crossover Point

When testing flow rates *below* the meter's crossover point, only the low flow register test hand will move. Record the initial reading (low flow odometer and low flow test circle). To determine the amount of water that has passed through the meter during test, take the new reading from the low flow test circle. If more than one revolution of the test circle, take a new reading from both the low flow odometer and the low flow test circle. The difference between the initial and final reading is then compared to that recorded by the test meter or test tank.

Testing Above Crossover Point

When testing flow rates at or *above* the meter's crossover point, the high flow and low flow register test hands will move. This is because both sides of the meter, disc and turbo, operate simultaneously at these flow rates. The disc side of the meter operates at all flow rates to keep the chamber free of debris that might enter the meter. Record the initial readings (high flow odometer and high flow test circle, low flow odometer and low flow test circle). If less than one revolution of the high flow test circle, record both the new high flow and low flow test circle readings. Add the amount of flow recorded by the high flow and low flow test circles during the test to determine the **total** flow through the meter. Compare this to that recorded by the test meter or test tank.

If more than one revolution of the high flow test circle occurs, take new readings from the low flow odometer, high flow and low flow test circles and add all complete high flow test circle revolutions to this. Once again, the amount of flow recorded by the high flow and low flow test circles must be added together and combined to determine the **total** flow through the meter. This is then compared to that recorded by the test meter or test tank.

A simplified alternative to recording the initial and final odometer readings on the high flow and low flow odometers, is to record the number of complete revolutions of the test hand on the high flow and/or low flow test circles during test. This is then added to the difference between the initial and final position of the test hands on the test circles to determine the **total** flow through the meter.

For correct testing procedures, and test volumes based upon meter flow rates, please refer to *AWWA M-6 Manual*. Starting the test when the register test circle hands are on zero and operating the meters through complete revolution of the test circles are desirable operating procedures to follow.

CAUTION

THE TEST HANDS OPERATE INDEPENDENTLY OF ONE ANOTHER. FOR EXAMPLE, DURING METER OPERATION AT FLOWS BELOW CROSSOVER, THE LOW FLOW TEST HAND WILL REVOLVE WHILE THE HIGH FLOW TEST HAND IS STATIONARY, ALLOWING HIGHER READINGS ON THE LOW FLOW ODOMETER ONLY.

Maintenance Equipment

The tools and equipment recommended for use in servicing and maintaining Recordall Compound Series meters consist of the usual complement of hand tools used by plumbers and mechanics.

Preventive Maintenance

The purpose of preventive maintenance is to ensure efficient operation and long life of the meter by detecting and correcting any defect that might damage the meter or cause it to fail. Preventive maintenance consists of periodic inspection, accuracy testing, and cleaning procedures.

Periodic Inspection

- Visually inspect the meter for missing hardware, loose screws, broken or scratched register lenses or any other signs of wear or deterioration.
- Verify that the meter is operating at the proper flow rate and pressure. A loss in pressure, coupled with a decrease in flow rate, may indicate that the screen in the upstream pipeline—or the meter itself—is clogged with foreign material and needs cleaning.

Cleaning

- Clean all dirt, grease, moisture or other foreign material from the exterior of the meter. After cleaning, rinse thoroughly with water.
- In the event that system pressure has been reduced and the upstream filter or meter is clogged, the foreign material must be flushed out. To flush the screen, open the cleanout plug and purge the foreign material with fresh water from the service line. If cleaning the screen does not restore system pressure, the compound meter also should be flushed by purging with fresh service water through the cleanout plugs located on the housing.

SERVICING PARTS AND ASSEMBLIES

When the performance of a compound meter indicates a need for servicing, refer to the following instructions pertaining to removal, inspection and installation of service parts and assemblies. Contact Badger Meter if you need additional help.

Removing the High Flow Turbo Meter Head Assembly

A typical installation would be equipped with drain and piping valves. To inspect or replace components of the High Flow Turbo Head Assembly, close the upstream and downstream valves. However, if the installation does not have a drain valve, proceed as follows to relieve pressure. See [Figure 8](#).

⚠ WARNING

UPSTREAM AND DOWNSTREAM VALVES MUST BE CLOSED BEFORE ATTEMPTING TO REMOVE THE METER HEAD FROM THE HOUSING. FAILURE TO DO SO CAN LEAD TO THE HEAD BEING "EJECTED" FROM HOUSING, CAUSING PERSONAL INJURY AND/OR PROPERTY DAMAGE!

1. Loosen each of the High Flow Turbo Head Assembly bolts about 1-1/2 turns. Do not completely remove the bolts.
2. If the O-ring between the High Flow Turbo Head Assembly and the housing is secure and not leaking, pry the Measuring Element Assembly loose by inserting a screwdriver blade where the head and housing join together.

⚠ CAUTION

BE SURE THAT ANY WATER COMING OUT OF THE METER HEAD DOES NOT SPRAY ONTO ELECTRICAL EQUIPMENT AND CREATE A SHOCK HAZARD.

3. Allow the meter to drain and relieve internal pressure.
4. When pressure is relieved, remove the head bolts. Lift the Turbo measuring element assembly from the housing.
5. Follow the instructions for ["Servicing the Chamber and Disc"](#) on page 14.

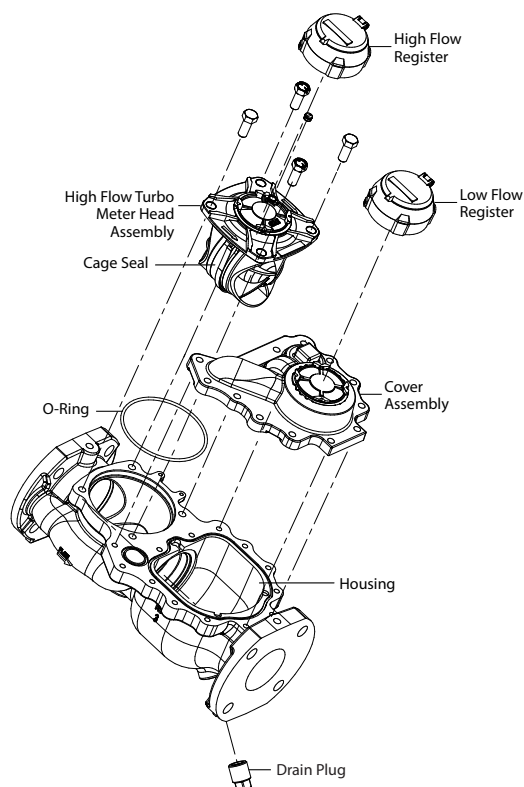

Figure 8: Removing the high flow turbo meter head assembly

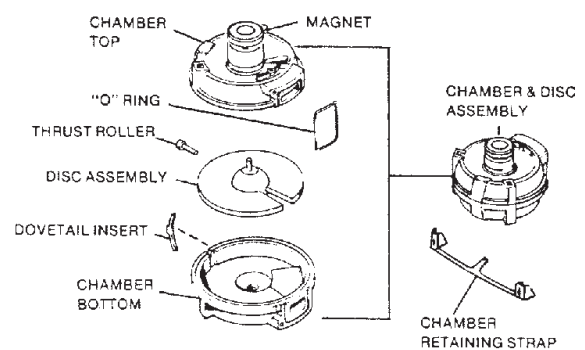
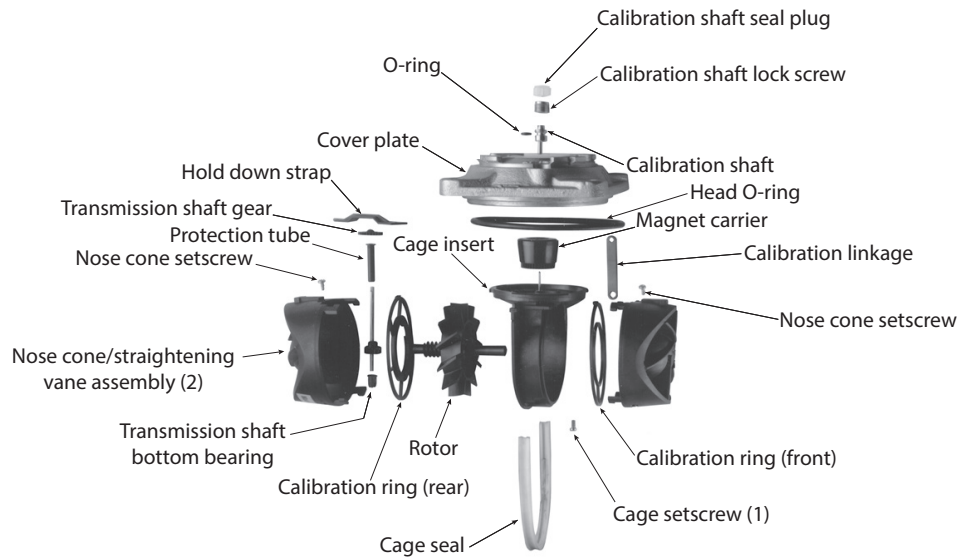
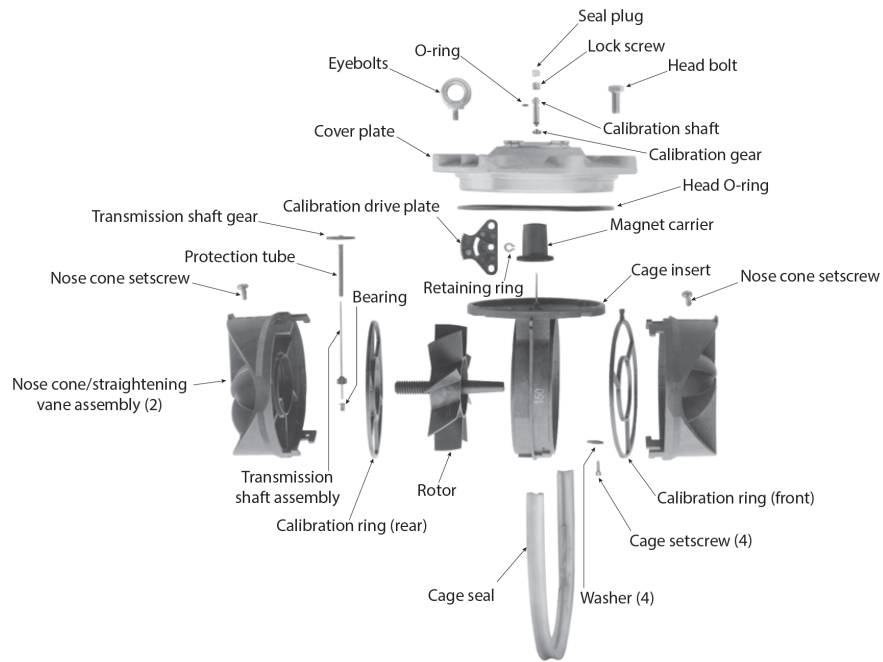

Figure 9: Chamber and disc assembly



2 in., 3 in. and 4 in.



6 in.

Figure 10: High flow turbo measuring element assemblies

Removing the Turbo Measuring Element Assembly from the Cover Plate

1. Remove the O-ring and cage seal.
2. Check for damage and clean or replace prior to reassembly.
3. To remove the measuring element from the cover, remove the calibration shaft seal plug and the lock screw.
4. Place the cover register-side down on a table or flat surface.
5. Lightly tap or press the calibration shaft from the wet side out of the bore in the cover (2 in., 3 in. and 4 in. only). Do not strike or bend the calibration linkage.
6. The measuring element insert can be removed from the cover plate for service or replacement by removing the cage set screws (quantity of one, except for the 6 in. size.)
7. Holding the cover plate in one hand, rotate the thermoplastic element counter-clockwise until the bayonet-like tabs are aligned with open areas of the cover plate (2 in., 3 in. and 4 in. only).
8. Remove the element from the cover plate.

Removing the Magnet Carrier/Top Gear Set

1. To remove the magnet carrier from the measuring element insert, lift it off the stainless steel pin.
2. Check the condition of the magnet and gear on the magnet carrier for damage or wear. If significant wear or damage is present, replace the magnet carrier.
3. Remove the hold-down strap.
4. Check the transmission shaft gear for damage or wear. If significant wear or damage is present, replace the gear.
5. Lift the gear off the shaft.

Removing the Straightening Vanes/Nose Cone

The straightening vanes are an integral part of the upstream and downstream nose cone assemblies. To gain access to them, remove the measuring element from the cover.

Remove the upstream nose cone to access the rotor, calibration ring and the transmission assembly.

1. To remove the nose cone, unscrew the upstream nose cone setscrew. For 2 in., 3 in. and 4 in. meters, slide the calibration linkage into the cage insert stop.
2. Take hold of the nose cone/straightening vanes and turn them clockwise, thereby disengaging the calibration linkage from the tab on the calibration ring and unlocking the bayonets of the nose cones from the cage (see [Figure 12 on page 12](#)).
3. If the tab of the calibration ring has not disengaged the linkage, rotate the ring carefully by pushing the struts at the interior of the element (between the straightening vanes and the rotor). Pull the nose cone assembly out from the measuring element insert. For 6 in. meters, remove the transmission gear by lifting it off the shaft, noting the alignment of the D-shaped bore with the flat on the shaft (required to align for assembly).
4. Remove the retaining ring that holds down the calibration drive plate, located under magnet carrier magnet (see [Figure 8 on page 8](#)). Remove drive plate. Rotate calibration ring until pin clears slot of cage. Take hold of the nose cone/straightening vanes and turn clockwise. Pull the nose cone assembly out from the measuring element insert. Remove rotor assembly.

Removing the Calibration Mechanism

To disassemble the calibration ring assembly:

1. Remove the calibration shaft seal plug and unscrew the calibration shaft lock screw from the cover plate.
2. Remove the calibration shaft thrust washer and calibration shaft. Press the calibration shaft out of the cover plate from below.
3. If a leak exists at this point in the disassembly of the meter, remove the calibration shaft O-ring. Before reinserting the O-ring, apply a light coat of silicon grease to it.
4. Clean all parts.

To gain access to the calibration ring, the straightening vane/nose cone must be removed. See [“Removing the Magnet Carrier/ Top Gear Set” on page 10](#) for instructions.

To remove the calibration ring from the nose cone assembly:

1. Align the ring slots with the bayonets of the nose cone assembly (located on inner ring of calibration ring).
2. Carefully lift the calibration ring from the nose cone assembly.

To reinstall the calibration mechanism, follow this procedure in reverse.

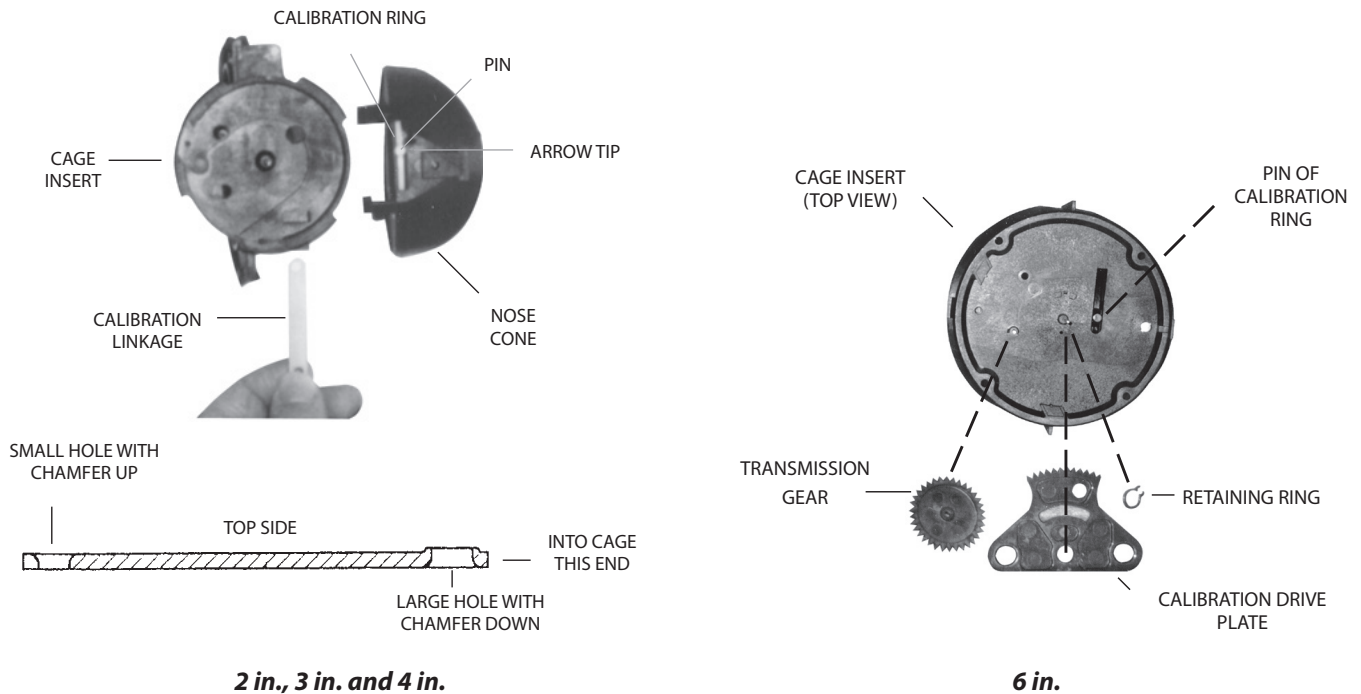

Figure 11: Calibration ring/linkage assemblies

Reassembling the Calibration Mechanism

1. Align the pin on the perimeter of the calibration ring with the arrow tip located on the nose cone assembly (see [Figure 11](#)).
2. For 2 in., 3 in. and 4 in. sizes, install the calibration linkage into the cage with the larger hole to engage the calibration ring tab, with the side of chamfered edge of the hole towards the nose cone assembly (see [Figure 11](#)).
3. With the calibration linkage fully inserted to the cage stop, install the nose cone onto the cage and rotate it counter-clockwise to engage the pin of the ring to the calibration linkage. The hole of the calibration linkage has to be aligned onto the calibration shaft, engaging it fully so that the calibration ring cannot vibrate during operation.
4. Tighten the calibration shaft lock screw to securely hold the calibration ring in position.

After servicing or replacing the calibration mechanism, check the accuracy and calibration according to the instructions in the [Recordall Turbo Series Meter User Manual](#).

Inspecting the Rotor and Bearings

To inspect the rotor, remove the nose cone assembly from the measuring element insert as described in *"Removing the Magnet Carrier/Top Gear Set" on page 10*.

Check the rotor worm and blades for signs of damage and wear. Also inspect the bearing bushings in the front and rear shaft. If damage or wear has occurred, replace the part (see *Figure 12*). If water deposits are found, remove any mineral deposits from the rotor blade surfaces, cage insert interior diameter, and nose cone vanes and mating surfaces.

Inspect the rotor bearing pins in the straightening vane and nose cone assembly for signs of damage and wear (see *Figure 12*). The spherical end of the bearing pin must not show any drag lines and/or wear.

NOTE: Only highly-polished bearing pin ends provide a minimum of friction and optimal meter performance. Bearing pins are an integral part of the straightening vane and nose cone assembly. Wear or damage would require the replacement of this component.

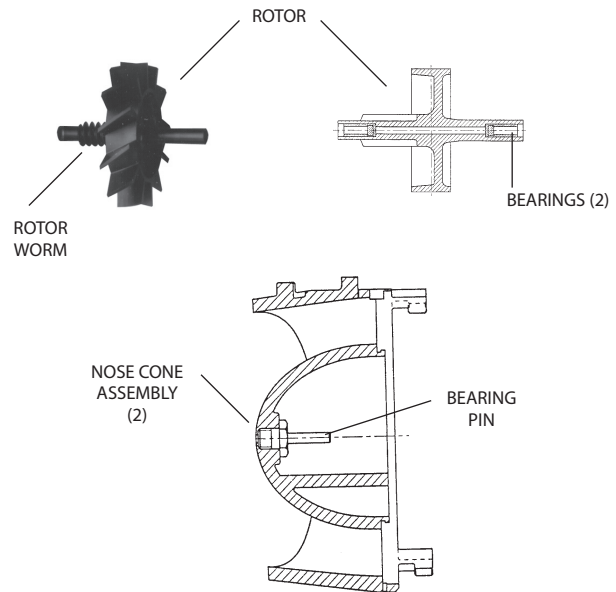

Figure 12: Rotor and nose cone assembly (2 in., 3 in., 4 in. and 6 in. turbo head assemblies)

Reassembling the Rotor and Bearings

1. Install the rear nose cone to the cage. See *"Removing the Magnet Carrier/Top Gear Set" on page 10*.
2. Place the rotor assembly with the worm gear side leading through the cage.
3. Place the rotor assembly on the rear rotor bearing pin, while tipping the assembly back so that the opening is up. See *"Removing the Calibration Mechanism" on page 10* for instructions on assembling the calibration rings with the nose cone assembly.
4. Insert the front nose cone assembly partially onto the cage insert, engaging the bearing pin with the front bearing of the rotor.
5. Tilt the measuring element insert assembly forth and back to see that the rotor now engages the bearing pins on the straightening vane/nose cones and is free to rotate and slide.

CAUTION

DO NOT FORCE THE NOSE CONE ASSEMBLY INTO THE CAGE INSERT. BE SURE THE ROTOR ENGAGES BOTH THE FRONT AND REAR ROTOR BEARING PINS PRIOR TO PRESSING THE NOSE CONE ASSEMBLY FULLY INTO THE CAGE INSERT.

6. Press the nose cone assembly fully into the cage insert and turn it counter-clockwise, catching the calibration linkage in the slot.
7. Check to see that the rotor spins freely. If it does not, remove the nose cone assembly and repeat the procedure.
8. Install and tighten the nose cone assembly setscrew.
9. Holding the cover plate in one hand, align the thermoplastic cage bayonet-like tabs with the slots in the cover plate (2 in., 3 in. and 4 in. only).
10. Rotate the element clockwise until the cage setscrew hole is aligned. Install and tighten the cage setscrews (quantity of 1 for 2 in., 3 in. and 4 in. meters, a quantity 4 for the 6 in. meter).

Removing the Rear Nose Cone

Rear nose cone removal requires transmission shaft removal.

1. Remove the strap over the gear (2 in., 3 in., and 4 in. only).
2. Lift the gear off the shaft. The shaft has a flat spot that aligns with the D-shaped bore in the gear.
3. Remove the nose cone set screw.
4. Remove the protection tube by carefully pressing (with flat surface of blade screwdriver) on the bottom of the tube located inside the rear nose cone.
5. Press to release the detent lock, about 1/4 in. vertical travel, then lift the tube out from the top of the cage insert.
6. Lift the transmission shaft assembly up and out of the bottom bearing, then slide shaft downward and diagonally out (towards you) to remove it from the nose cone/cage assembly.
7. Holding cage firmly with one hand, rotate the nose cone clockwise with other hand, then carefully lift it off the cage.

To reinstall the rear nose cone, follow this procedure in reverse. See *"Inspecting the Rotor and Bearings"* on page 12 for instructions on reassembling the components.

Reinstalling the High Flow Turbo Meter Head Assembly

- Use a new O-ring after each teardown and reassembly. Apply a light coat of silicone grease to the O-ring to aid in assembly.
- To provide a tight seal, make sure the surfaces of the housing and meter head are clean and free of any old O-ring material.
- Be careful not to force the measuring element insert into the meter housing. If you experience any binding, do not force the element into the housing. Remove the element from the housing and properly reinsert the unit.

NOTE: Head bolts should be tightened similar to that on a car tire. First insert the bolts and snug-fit each. Then, using a crisscross pattern, tighten the bolts down. Following this pattern, the meter head will not turn and the rotor will remain perpendicular to the flow, eliminating any potential flow distortion. Tighten the head bolts to 10...11 ft-lb for the 2 in. size, and 35...40 ft-lb for the 3 in., 4 in. and 6 in. sizes.

Removing the Low Flow Side

A typical installation would be equipped with drain and piping valves. To inspect or replace components of the Low Flow side, close the upstream and downstream valves. If the installation does not have a drain valve, proceed as follows to relieve pressure. See [Figure 8 on page 8](#).

WARNING

UPSTREAM AND DOWNSTREAM VALVES MUST BE CLOSED BEFORE ATTEMPTING TO REMOVE METER HEAD FROM HOUSING. FAILURE TO DO SO CAN LEAD TO THE HEAD BEING "EJECTED" FROM HOUSING, CAUSING PERSONAL INJURY AND/OR PROPERTY DAMAGE!

1. Loosen each of the Low Flow Cover Assembly bolts about 1-1/2 turns. Do not completely remove the bolts.
2. If the O-ring between the Low Flow Cover Assembly and the housing is secure and not leaking, pry the Measuring Element Assembly loose by inserting a screwdriver blade where the head and housing join.

CAUTION

BE SURE THAT ANY WATER COMING OUT OF THE METER HEAD DOES NOT SPRAY ONTO ELECTRICAL EQUIPMENT AND CREATE A SHOCK HAZARD.

3. Allow the meter to drain and relieve internal pressure.
4. When pressure is relieved, remove the head bolts.

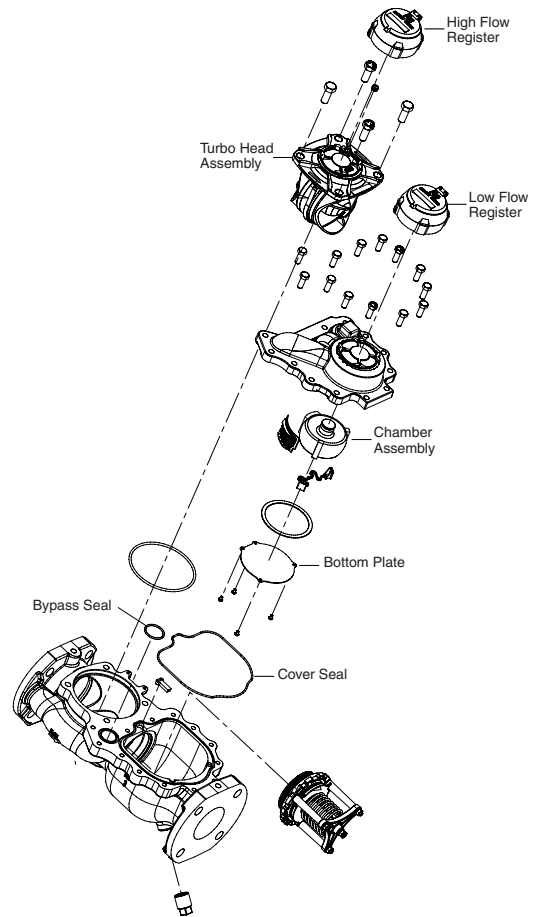

Figure 13: Removing the low flow side

Servicing the Chamber and Disc

1. Remove the screws holding the bottom plate on the cover assembly.
2. Remove the bottom plate.
3. Remove the chamber retaining strap.
4. Lift out the chamber and disc assembly.
5. Inspect the chamber and parts (see [Figure 9 on page 8](#)) for visible signs of wear. The thrust roller and dovetail insert should be replaced if worn. Replace the chamber if wear is evident on disc spindle where it contacts the crossbar magnet drive or the balls or if the disc plate is worn by foreign material. If water deposits are found, remove any mineral deposits from the disc and chamber interior surfaces. Before replacing the chamber in the meter head, make certain that the area surrounding the magnet in the meter head is clean.

Valve Assembly

Removing the Valve Assembly

With the cover assembly removed, the valve assembly is exposed for service.

1. Remove the lock pawl (see [Figure 14](#)).
2. Turn the valve assembly counter-clockwise to unscrew it from the housing.
3. Lift the valve assembly out of the housing.

Replacing the Valve Assembly

If any portion of the valve assembly requires replacement, we recommend replacing the entire valve assembly.

1. Check the O-ring for damage. Clean or replace prior to reassembly.
2. Drop in the new assembly, being certain the O-ring is installed.
3. Turn the assembly clockwise to thread it into the housing.
4. Drop the lock pawl back into position to lock in the assembly.

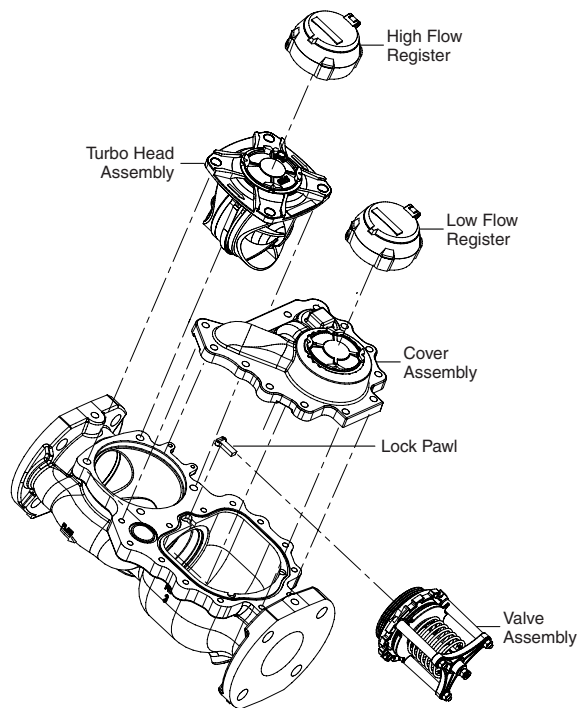

Figure 14: Valve assembly

Reinstalling the Cover Assembly

Badger Meter recommends that a new O-ring be used after each teardown and reassembly of the cover assembly. To assure a tight seal, make sure the O-ring is positioned correctly on the housing and that the O-ring and cover assembly are clean and free of dirt or residual traces of old O-ring material. If necessary, use silicone grease to help retain the O-ring and to serve as a lubricant in reassembling it to the housing.

Cover bolts should be tightened in a crisscross pattern similar to Turbo head bolts. Torque 2 in. and 3 in. cover assembly bolts to 16...18 ft-lb. Torque the bolts for the 4 in. and 6 in. cover assemblies to 35...40 ft-lb.

SPECIFICATIONS

Compound Series Model	2 in. (50 mm)	3 in. (80 mm)	4 in. (100 mm)	6 in. (150 mm)
Meter Flanges, Class 150	2 in. elliptical or round (50 mm)	3 in. round (80 mm)	4 in. round (100 mm)	6 in. round (150 mm)
Typical Operating Range (100% ± 1.5%)	0.5...200 gpm (0.1...45 m ³ /h)	0.5...450 gpm (0.1...102 m ³ /h)	0.75...1000 gpm (0.17...227 m ³ /h)	0.75...2000 gpm (0.17...454.4 m ³ /h)
Low Flow Registration (95% minimum)	0.25 gpm (0.06 m ³ /h)	0.25 gpm (0.06 m ³ /h)	0.375 gpm (0.09 m ³ /h)	0.375 gpm (0.09 m ³ /h)
Maximum Continuous Flow	170 gpm (38.3 m ³ /h)	400 gpm (90.3 m ³ /h)	800 gpm (181.6 m ³ /h)	1500 gpm (340.5 m ³ /h)
Pressure Loss at Maximum Continuous Flow	5.4 psi at 170 gpm (0.38 bar at 38.3 m ³ /h)	6.0 psi at 400 gpm (0.41 bar at 90.3 m ³ /h)	11.0 psi at 800 gpm (0.75 bar at 181.6 m ³ /h)	9.3 psi at 1500 gpm (0.64 bar at 340.5 m ³ /h)
Crossover Flow Rate, Typical	12 gpm	12 gpm	20 gpm	30 gpm
Pressure Loss at Crossover	3.5 psi (0.24 bar)	4.0 psi (0.28 bar)	4.0 psi (0.28 bar)	5.0 psi (0.35 bar)
Minimum Crossover Accuracy	97%	97%	97%	95%
Maximum Operating Pressure	150 psi (10 bar)			
Maximum Operating Temperature	105° F (41° C)			
NPT Test Port	1-1/2 in.		2 in.	
Materials				
Meter Housing & Cover	Lead-free bronze alloy			
Turbo Cast Head	Lead-free bronze alloy			
Nose Cone & Straightening Vanes	Thermoplastic			
Rotor	Thermoplastic			
Rotor Radial Bearings	Lubricated thermoplastic			
Rotor Thrust Bearing	Sapphire jewels			
Rotor Bearing Pivots	Passivated 316 stainless steel			
Calibration Mechanism	Stainless steel & thermoplastic			
Measuring Chamber & Disc	Thermoplastic			
High Flow Valve	Stainless steel & thermoplastic			
Magnets	Ceramic			
Register Lens	Glass			
Register Housing & Cover	Thermoplastic or bronze			
Trim	Stainless steel			
Drain Plug (3/4 in.)	Stainless steel or lead-free bronze alloy			
Test Plug	Stainless steel or lead-free bronze alloy			