



OPTISONIC 6300 P Technical Datasheet

Portable ultrasonic clamp-on flowmeter for liquids

- User friendly operation using a tablet or smart phone
- Quick and easy installation with a wireless web application
- Exchangeable transducers mounted in a sensor rails for fast installation and high performance

| | |
|---|----|
| 1 Product features | 3 |
| 1.1 Portable clamp-on flowmeter | 3 |
| 1.2 Variants and options | 5 |
| 1.3 Measuring principle | 9 |
| 2 Technical data | 10 |
| 2.1 Technical data | 10 |
| 2.2 Dimensions and weight | 16 |
| 2.2.1 Clamp-on sensor | 16 |
| 2.2.2 Converter | 17 |
| 2.2.3 I/O box | 18 |
| 2.2.4 Hardcase on wheels | 19 |
| 2.2.5 Softcase | 19 |
| 3 Installation | 20 |
| 3.1 Intended use | 20 |
| 3.2 Find location and determine data | 20 |
| 3.2.1 Horizontal (long) pipes | 21 |
| 3.2.2 Bends in 2 or 3 dimensions | 21 |
| 3.2.3 T-section | 22 |
| 3.2.4 Open feed or discharge | 22 |
| 3.2.5 Bends | 23 |
| 3.2.6 Position of control valve | 24 |
| 3.2.7 Position of pump | 24 |
| 3.3 Start up UFC 300 P signal converter | 25 |
| 3.4 Step 3: Mount the sensor rails | 28 |
| 3.5 Connect the sensor cable | 31 |
| 4 Electrical connections | 32 |
| 4.1 Safety instructions | 32 |
| 4.2 Power supply | 32 |
| 4.3 Connection of the signal cables | 34 |
| 4.4 Connection diagrams | 35 |
| 5 Application form | 40 |
| 6 Notes | 42 |

1.1 Portable clamp-on flowmeter

The new OPTISONIC 6300 P flowmeter is the portable solution for liquid flow measurements based on the proven stationary ultrasonic technology. It combines the straightforward and easy to install sensor rails with a portable battery-powered flow converter for 1 or 2 path measurements.

The portable converter has full measurement functionality with an integrated data logger and can be connected to a handheld smart device by Bluetooth or USB cable. Flexibility and ease of use make the OPTISONIC 6300 P the ideal solution for flow measurement in various applications and virtually all sectors of industry.

Attach the sensor unit to the tube and download/install the mobile application on your device. Configure your measuring application by following the installation wizard. The data is saved on your handheld device and is ready to be evaluated.



Highlights

- Sensor rails with exchangeable transducers
- Fixating units with straps or magnets
- Integrated click and turn mechanism for easy access
- User interface by handheld smart device
- Android application with installation wizard
- Real time measurement or data-logging
- Up to 16 hours battery life
- 1 or 2 path measurement
- Energy measurement

Industries

- Chemicals
- Petrochemicals
- Water and wastewater
- Oil & Gas
- Semi-conductor
- Food & Beverages
- Pharmaceuticals
- HVAC
- Metal & Steel

Applications

- Process optimization
- Checking of in-line flowmeters
- Commissioning of process systems
- Checking of pump performance
- Temporary replacement of defective flowmeters
- Periodic flow capacity test hydrants
- General flow related problem solving

1.2 Variants and options

The OPTISONIC 6300 P is a battery powered ultrasonic clamp-on flowmeter that can be easily installed on the outside of piping to measure the flow rate of liquids. The OPTISONIC 6300 P is intended for temporary flow measurement. It consists of a combination of one or two clamp-on sensor(s) and one hand-held electronic signal converter.

The OPTISONIC 6300 P is available in several variants for different pipe sizes and measurement setups. The equipment is delivered in a soft case or optional hardcase with 2 or 3 organiser layers to carry and store the converter, its transducers, the mounting materials and the main accessories.



Standard included:

- UFC 300 P signal converter
- Transducer set (s)
- Mounting materials and rail(s)
- Coupling grease
- Tape measure
- Transducer signal-check block
- Quickstart
- Casing (soft- or hardcase)





Flow sensor options

- Transducer set for small pipe sizes DN15...DN150 / ½...6"
- Transducer set for medium pipe sizes DN50...DN1500 / 2...60"
- Transducer set for large pipe sizes DN200...DN4000 / 8...160"

The small and medium transducers can be mounted in one mounting rail for pipe diameters up to DN250 / 10". Use a second mounting rail for bigger pipe sizes. Up to two transducer sets can be connected to the converter to set up a dual-path or dual pipe measurement.



I/O connection box

The I/O connection box has to be used to wire the available in and outputs like current outputs, pulse output or the current inputs for temperature measurements..

The I/O box is available in 3 variants:

- Standard I/O box
- I/O box with two temperatures transmitters
- I/O box with two temperatures transmitters and two clamp-on temperature sensors

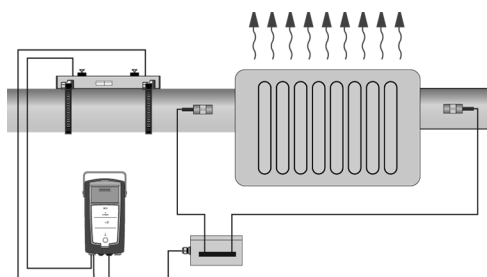

Energy measurement

Standard the OPTISONIC 6300 P is provided with a measurement option for thermal energy. This requires the input of 2 temperature measurements in addition to the flow measurement.



Optional thickness gauge

For setting up the flow measurement correctly, the pipe wall thickness must be known.

To measure this, a pipe wall thickness gauge can be ordered with the OPTISONIC 6300 P.



Standard fixation units

Each mounting rail consists of two exchangeable fixation units with a unique "click-and-turn" mechanism. The fixation units can easily be attached to the pipe by using straps. When the rail is installed, the "click-and-turn" mechanism allows access to the pipe/transducer contact surface at any time. For smaller pipe sizes up to DN250, metal straps are used. For large pipe sizes, specially designed nylon straps are available in lengths of 3.5 meters / 11.5 feet or 13.5 meters / 44.3 feet to attach the mounting rails up to pipe diameters of DN4000/160".



Magnetic fixation units

Optionally, to attach or detach the sensor rails onto the pipe wall, fixation units with magnets are available. This is only possible with pipe walls that have magnetic properties (e.g. carbon steel).



Signal cables extension set

The 3-meter / 9.8 feet long signal cables are colour coded and have to be plugged in the signal converter during installation. Extension cables with a length of 7 meters / 22.9 feet are optionally available for the larger pipe diameters or when the converter needs to be placed on a distance, further as the 3-meter / 9.8 feet cable length.



OPTISONIC 6300 P Application

The UFC 300 P converter has to be controlled and operated with an Android application. The App is free available in the app store and can be installed on an Android 10+ smart device.



Tablet

Optionally, a factory configured grade tablet with an installed App is available, which we have selected and tested for use outdoors. An ideal option for users who want to start measuring without any concerns.



Car adapter charger

Optionally, a car charger cable is available to use or charge the converter with a 12 VDC car socket.



USB cable

A USB cable with a 15 pins connector is available to connect the converter hard-wired to a hand-held smart device.

1.3 Measuring principle

- Like canoes crossing a river, acoustic signals are transmitted and received along a diagonal measuring path.
- A sound wave going downstream with the flow travels faster than a sound wave going upstream against the flow.
- The difference in transit time is directly proportional to the mean flow velocity of the medium.

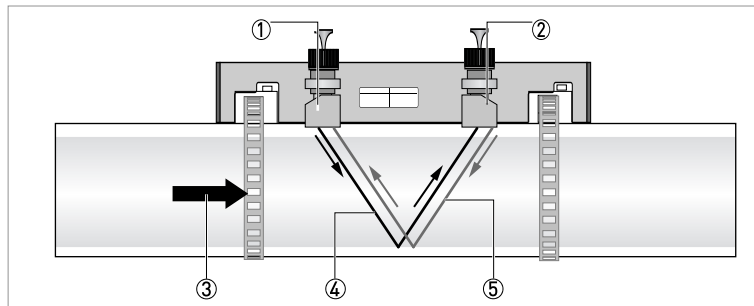

Figure 1-1: Measuring principle (example reflected path set-up)

- ① Transducer A
- ② Transducer B
- ③ Flow velocity
- ④ Transit time from transducer A to B
- ⑤ Transit time from transducer B to A

2.1 Technical data

- *The following data is provided for general applications. If you require data that is more relevant to your specific application, please contact us or your local sales office.*
- *Additional information (certificates, special tools, software,...) and complete product documentation can be downloaded free of charge from the website (Downloadcenter).*

Measuring system

| | |
|--------------------------|---|
| Measuring principle | Ultrasonic transit time |
| Application range | Flow measurement of liquids |
| Measured value | |
| Primary measured value | Transit time |
| Secondary measured value | Volume flow, mass flow, flow speed, flow direction, speed of sound, gain, signal to noise ratio, diagnosis value, reliability of flow measurement, quality of acoustic signal, thermal energy (requires 2 x temperature input). |

Design

| | |
|--|--|
| | The measurement system consists of one or two measuring sensors and a portable signal converter. |
| Signal converter | |
| Portable housing | UFC 300 P |
| Measuring sensor | |
| Standard | Single or dual sensor rail with 500 kHz, 1 MHz or 2 MHz transducers |
| Optional | OPTISONIC 6300 flow sensors using cable adaptors |
| Normal pipe diameter ranges (recommended) | |
| Small transducers (2 MHz) | DN15...150 / ½...6" (1 rail) |
| Medium transducers (1 MHz) | DN50...250 / 2...10" (1 rail) |
| | DN200...1500 / 8...60" (2 rail) |
| Large transducers (500 kHz) | DN200...4000 / 8...160" (2 rail) |
| Options | |
| Outputs | 0(4)...20 mA, pulse, frequency and/or status output with optional I/O box. |
| Inputs | 0(4)...20 mA (2 x) with optional I/O box. |
| Counters | 4 internal counters with a maximum of 8 counter places, for counting volume, energy and/or mass units. |
| USB | 1 x host port (Mobile device USB-C via I/O connection of OPTISONIC 6300 P to make a connection with Android device). |
| Self diagnostics | Integrated verification, diagnostic functions: flowmeter, process, measured value, empty pipe detection, bar graph. |

| User interface | |
|--|---|
| Operator elements and indicators | 1 on/off key with LED indication |
| | LED indication Bluetooth connection |
| | LED indication charging battery |
| | LED bar graph for status of battery charge |
| Display functions on Android device | |
| Menu | Wizard for setup and configuration of measurements. |
| | Support for the configuration of 2 path / 2 pipe or 2 path / 1 pipe measurement. |
| | Averaging, adding or subtracting of measurement results of 2 path measurements. |
| | Storage of measurement configurations as site file. Maximum number of site files is 100. |
| | Measurement data can be displayed as value or as bar or trend graph. |
| Thermal energy measurement | By input of 2 temperature sensors providing a temperature difference, thermal energy can be calculated. |
| Data logger | Logging of free selectable measured and calculated values. Data storage up to 16 GB/500 logfiles on fielddevice. Per log file, a maximum of 1.500.000 values can be stored. Display of logged data through line graphs. |
| Languages | English, French, German, Spanish, Italian, Chinese, Czech, Polish, Dutch |
| | Other languages on request. |
| Units | Metric, British and US units selectable from list / free unit. |

Measuring accuracy

| | |
|-------------------------|--|
| Reference conditions | Medium: water |
| | Temperature: 20°C / 68°F |
| | Pressure: 1 bar/14.5 psi |
| | Straight inlet section: 10 DN |
| | Straight outlet section: 5 DN |
| Maximum measuring error | ≥ DN50/2 inch < ± 1% of the actual measured flow rate; for 0.5...20 m/s / 1.64...65.6 ft/s < ± 5 mm/s / 0.2 inch/s for 0.1...0.5 m/s / 0.33...1.64 ft/s |
| | < DN50/2 inch < ± 3% of the actual measured flow rate; for 0.5...20 m/s / 1.64...65.6 ft/s < ± 15 mm/s / 0.6 inch/s for 0.1...0.5 m/s / 0.33...1.64 ft/s |
| Repeatability | < ± 0.2% |

Operating conditions

| Temperature | |
|------------------------------------|---|
| Process temperature | Standard version: -40...+120°C / -40...+248°F |
| Ambient temperature | Sensor: -40...+70°C / -40...+158°F |
| | Signal converter: -10...+45°C / +14...+113°F (Humidity: 5...80%, non condensing) |
| Ambient pressure | Up to an altitude of 3000 / 9843 feet meters above sea level |
| Ambient conditions | Signal converter and sensor rails can be used in wet conditions, for indoor and outdoor use. |
| | Pollution degree of the intended environment PD=3 |
| Storage temperature | -30...+80°C / -22...+176°F (Humidity: 5...80%, non condensing) |
| Pipe specifications | |
| Material | Metal, plastic, ceramic, asbestos cement, internal / external coated pipes (coatings and liners fully bonded to pipe wall). |
| Pipe wall thickness | < 200 mm / 7.87" |
| Liner thickness | < 20 mm / 0.79" |
| Media properties | |
| Physical condition | Liquids |
| Viscosity | < 200 cSt (general guideline) |
| | For detailed information please contact your local representative. |
| Permissible gas content (volume) | ≤ 2% |
| Permissible solid content (volume) | ≤ 5% |
| Recommended flow velocity | 0.1...20 m/s / 0.360 ft/s |

Installation conditions

| | |
|---------------------------|--|
| Measurement configuration | Single pipe, single path |
| | Single pipe, dual path |
| | Dual pipe, dual path |
| Inlet run | ≥ 10 DN straight length |
| Outlet run | ≥ 5 DN straight length |
| Dimensions and weights | For detailed information refer to <i>Dimensions and weight</i> on page 16. |

Materials

| | |
|-----------|--|
| Sensor | Anodized aluminium (rail) |
| Converter | Polyamide PA12, covered with TPE soft touch layer on the sides |
| Hardcase | Polypropylene, inner material EPP |
| Soft case | Polyester, inner material EPP |

Electrical connections

| | |
|----------------------|--|
| Power supply | Adaptor: charger input: 100...240 VAC (V_{nom}), 50...60 Hz |
| | Adaptor: charger output: 12 VDC, 2.33 A, P_{max} 28 W |
| | Flow converter power supply input: 12 VDC, 0.5 A, 6 W During charging, the current input increases to: 1.7 A (typical). |
| Overvoltage category | Signal converter category 1 |
| Battery pack | Charging time: \pm 8 hours |
| | Measuring operation time: \pm 16 hours |
| | Battery type: Lithium-Ion polymer (10200 mAh) |
| | Energy density: 72.4 Wh |
| | Weight 0.33 kg / 0.72 lb |
| Signal cable | Double braided shielded coax cables; 3 m / 9.8 ft Optional: extension cables; 7 m / 22.9 ft |
| USB ports | 1 x for Android device |
| Bluetooth | 2.4 GHz, 8.32 mW integral antenna build-in |
| Inputs / outputs | 15 pin connector for I/O interfacing with optional I/O box |
| | Optional: Pt100 input |
| | Function: Pt100 temperature input by 2 x KROHNE TT33C temperature transmitters build into an I/O box |
| | For specifications see TT33C data sheet. |
| | Optional: temperature input |
| | Function: temperature input by 2 x KROHNE TSR-W 30 clamp-on temperature sensors only in combination with I/O box with temperature transmitters. For specifications see TSR-W 30 data sheet. |

Inputs and outputs

| | |
|-----------------------------------|--|
| Connections | Inputs and outputs can only be connected using the optional I/O box. |
| Description of used abbreviations | V_{ext} = external voltage, R_L = load resistance, V_0 = terminal voltage, I_{nom} = nominal current |
| Current output | |
| Isolation | The output is not galvanically isolated from the other circuits. The - current out is connected to the metal connection panel and the connector shielding of the sensor. |
| Output data | All analog measurement parameters like volume and mass flow (at constant density), flow speed, speed of sound, gain, signal to noise ratio, reliability of flow measurement, quality of acoustic signal, thermal energy (requires input of temperature [2 x]). |
| Settings | Q = 0%: 0...20 mA; Q = 100%: 10...21.5 mA |
| | Error identification: 0...22 mA |
| Operating data | |
| Active | $V_{int,nom} = 15$ VDC $I \leq 22$ mA $R_L \leq 1$ k Ω |
| Passive | $V_{ext} \leq 32$ VDC $I \leq 22$ mA $V_0 \geq 1.8$ V at $I = 22$ mA $R_L \leq (V_{ext} - V_0) / I_{max}$ |

| Pulse or frequency output | |
|---------------------------|--|
| Isolation | The output is galvanically isolated from the other circuits. |
| Output data | For pulse counting and/or analog output: Volume flow, mass flow, thermal energy (requires input of temperature [2 x]) |
| | As analog output: Flow speed, speed of sound, gain, signal to noise ratio, reliability of flow measurement, quality of acoustic signal |
| Function | Can be set as a pulse output or frequency output |
| Settings | For Q = 100%: 0.01...10000 pulses per second or pulses per unit volume |
| | Pulse width: setting automatic, symmetric or fixed (0.05...2000 ms) |
| Operating data | |
| Active | $V_{nom} = 15 \text{ VDC}$ |
| | $f_{max} \leq 100 \text{ Hz}$: $I \leq 20 \text{ mA}$ open: $I \leq 0.05 \text{ mA}$ closed: $V_{0,nom} = 15 \text{ V at } I = 20 \text{ mA}$ |
| | $100 \text{ Hz} < f_{max} \leq 10 \text{ kHz}$: $I \leq 20 \text{ mA}$ open: $I \leq 0.05 \text{ mA}$ closed: $V_{0,nom} = 13.5 \text{ V at } I = 1 \text{ mA}$ $V_{0,nom} = 12.5 \text{ V at } I = 10 \text{ mA}$ $V_{0,nom} = 9 \text{ V at } I = 20 \text{ mA}$ |
| Passive | $V_{ext} \leq 32 \text{ VDC}$ |
| | $f_{max} \leq 100 \text{ Hz}$: $I \leq 100 \text{ mA}$ open: $I \leq 0.05 \text{ mA at } U_{ext} = 32 \text{ VDC}$ closed: $V_{0,max} = 0.2 \text{ V at } I \leq 10 \text{ mA}$ $V_{0,max} = 2 \text{ V at } I \leq 100 \text{ mA}$ |
| | $100 \text{ Hz} < f_{max} \leq 10 \text{ kHz}$: $I \leq 20 \text{ mA}$ open: $I \leq 0.05 \text{ mA at } V_{ext} = 32 \text{ VDC}$ closed: $V_{0,max} = 1.5 \text{ V at } I \leq 1 \text{ mA}$ $V_{0,max} = 2.5 \text{ V at } I \leq 10 \text{ mA}$ $V_{0,max} = 5.0 \text{ V at } I \leq 20 \text{ mA}$ |

| Status output | |
|-----------------------|--|
| Isolation | The output is galvanically isolated from the other circuits. |
| Function and settings | Settable as automatic measuring range change, indicator for direction of flow, overflow, error, operating point or empty pipe detection |
| | Status and/or control: ON or OFF |
| Operating data | |
| Active | $V_{int} = 15 \text{ VDC}$ $I \leq 20 \text{ mA}$ open: $I \leq 0.05 \text{ mA}$ closed: $V_{0, nom} = 15 \text{ V at } I = 20 \text{ mA}$ |
| Passive | $V_{ext} \leq 32 \text{ VDC}$ $I \leq 100 \text{ mA}$ open: $I \leq 0.05 \text{ mA at } V_{ext} = 32 \text{ VDC}$ closed: $V_{0, max} = 0.2 \text{ V at } I \leq 10 \text{ mA}$ $V_{0, max} = 2 \text{ V at } I \leq 100 \text{ mA}$ |
| Current inputs | |
| Isolation | The inputs are not galvanically isolated from the other circuits. |
| Function | Input of temperature, used for energy calculation in combination with flow measurement |
| | Range: $-50...500^{\circ}\text{C}$ / $-58...932^{\circ}\text{F}$ (default: $0...120^{\circ}\text{C}$ / $-32...248^{\circ}\text{F}$) |
| Operating data | |
| Active | $V_{int} = 15 \text{ VDC}$ $I \leq 22 \text{ mA}$ $I_{max} = 26 \text{ mA}$ (electronically limited) $V_{0, min} = 19 \text{ V with } I \leq 22 \text{ mA}$ No HART® |
| Passive | $V_{ext} \leq 32 \text{ VDC}$ $I \leq 22 \text{ mA}$ $I_{max} = 26 \text{ mA}$ (electronically limited) $V_{0, max} = 5 \text{ V with } I \leq 22 \text{ mA}$ No HART® |

Approvals and certificates

| CE | |
|--|--|
| This device fulfils the statutory requirements of the relevant directives. The manufacturer certifies successful testing of the product by applying the conformity mark on the device. | |
| | For more information on the directives, standards and the approved certifications, please refer to the declaration of conformity supplied with the device or downloadable from the manufacturer's website. |
| Other approvals and standards | |
| Protection category according to IEC 60529 | Sensor: IP66/67, NEMA 4X/6 |
| | Converter: IP65, NEMA 4 |
| | Hardcase on wheels: IP67, NEMA 6 |
| | Power adaptor: IP40, NEMA 1 |
| Shock resistance | IEC 60068-2-27 |
| | 30 g for 18 ms |
| Vibration resistance | IEC 60068-2-64 |
| | 1 g up to 2000 Hz |

2.2 Dimensions and weight

2.2.1 Clamp-on sensor

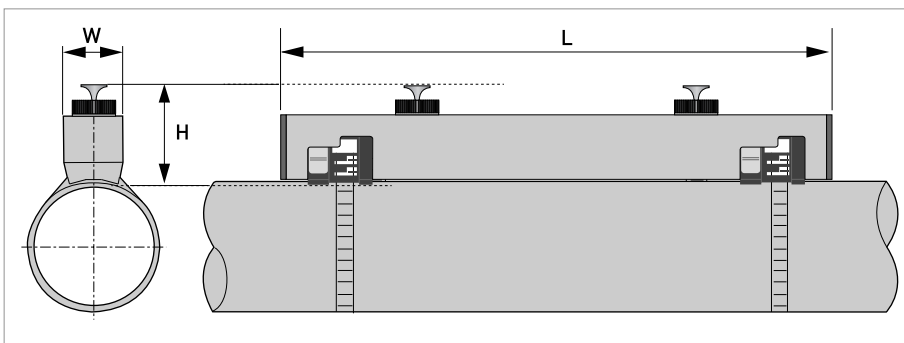

| Version | Dimensions [mm] | | | Approx. weight [kg] |
|---------|-----------------|------|------|---------------------|
| | L | H | W | |
| V1 | 406 | 76 | 39.2 | 2.1 ① |
| V2 | 406 | 81.5 | 42.7 | 2.2 ① |

① with transducers / cable, without mounting strap

| Version | Dimensions [inches] | | | Approx. weight [lb] |
|---------|---------------------|-----|------|---------------------|
| | L | H | W | |
| V1 | 16.0 | 3.0 | 1.54 | 4.6 ① |
| V2 | 16.0 | 3.2 | 1.68 | 4.8 ① |

① with transducers / cable, without mounting strap

2.2.2 Converter

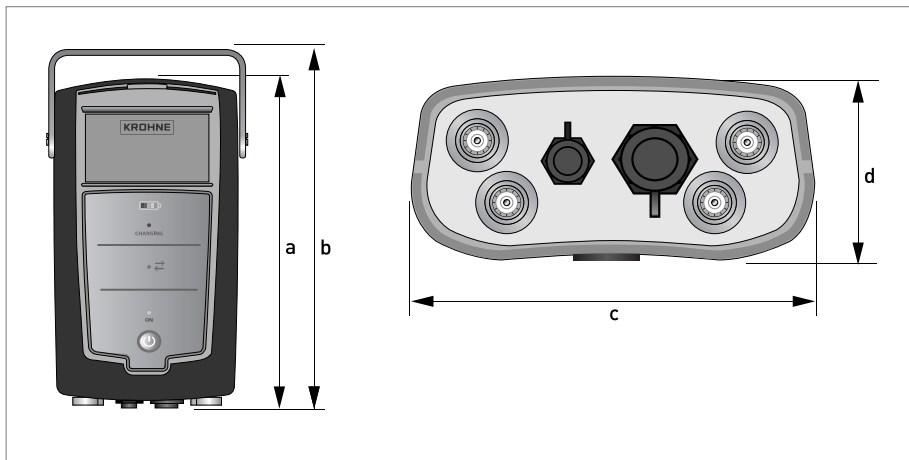

Dimensions UFC 300 P converter

| Dimensions [mm] | | | | Approx. weight [kg] |
|-----------------|-----|-----|----|---------------------|
| a | b | c | d | |
| 247 | 289 | 168 | 66 | 1.5 |

| Dimensions [inch] | | | | Approx. weight [lb] |
|-------------------|------|-----|-----|---------------------|
| a | b | c | d | |
| 9.7 | 11.4 | 6.6 | 2.6 | 3.3 |

2.2.3 I/O box

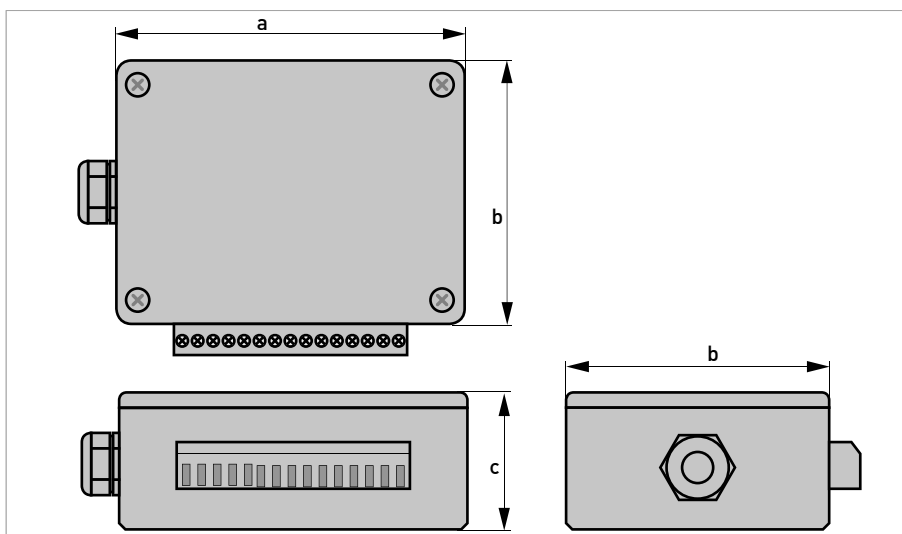

Dimensions I/O box

| Dimensions [mm] | | | Approx. weight [kg] |
|-----------------|------|----|---------------------|
| a | b | c | |
| 112.5 | 84.6 | 44 | 0.34 |

| Dimensions [inch] | | | Approx. weight [lb] |
|-------------------|-----|-----|---------------------|
| a | b | c | |
| 4.4 | 3.3 | 1.7 | 0.75 |

2.2.4 Hardcase on wheels

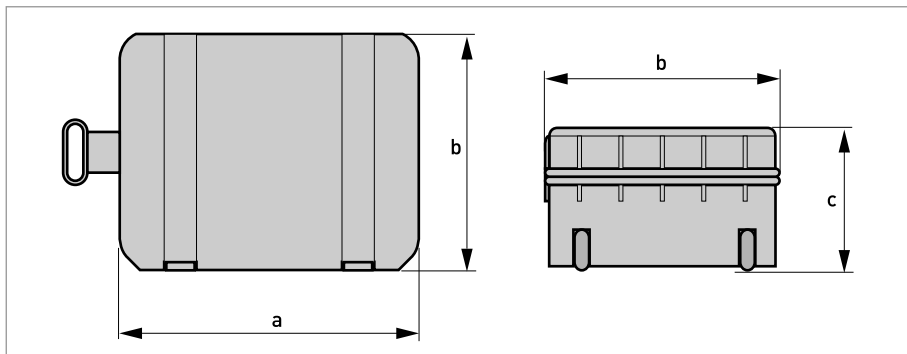

Dimensions hardcase on wheels

| Dimensions [mm] | | | Approx. weight [kg] |
|-----------------|-----|-----|---------------------|
| a | b | c | |
| 521 | 394 | 254 | 6.4 |

| Dimensions [inch] | | | Approx. weight [lb] |
|-------------------|------|----|---------------------|
| a | b | c | |
| 20.5 | 15.5 | 10 | 14.1 |

2.2.5 Softcase

Dimensions softcase

| Dimensions [mm] | | | Approx. weight [kg] |
|-----------------|-----|-----|---------------------|
| a | b | c | |
| 530 | 400 | 160 | 1.7 |

| Dimensions [inch] | | | Approx. weight [lb] |
|-------------------|------|-----|---------------------|
| a | b | c | |
| 20.9 | 15.8 | 6.3 | 3.8 |

3.1 Intended use

Responsibility for the use of the measuring devices with regard to suitability, intended use and corrosion resistance of the used materials against the measured fluid lies solely with the operator.

The manufacturer is not liable for any damage resulting from improper use or use for other than the intended purpose.

The **OPTISONIC 6300 P** portable clamp-on flow meter is specially designed for temporary liquid flow measurement in full pipe systems. The measurement system consists of transducers mounted in a sensor rail and a battery-powered portable converter and data logger. The system is controlled by a KROHNE Clamp-on APP installed on a smart device.

The OPTISONIC 6300 P is meant to be used temporarily for liquid flow and energy measurement. For example, the measured and calculated flow data is usable in process optimization, collecting additional process data, comparing flow data with existing flowmeters, verifying other flowmeters or flowmeter replacement during maintenance.

3.2 Find location and determine data

Finding transducer location:

The two most common ways to find the exact location are with the use of a fixed reference point or determination of transducer position with the use of a paper/plastic material roll. Both options are described in the manual.

Inlet, outlet and recommended mounting area

To perform an accurate flow measurement preferably mount the sensor rail at least 10 DN downstream of a flow disturbance like elbows, valves, headers or pumps. Follow the given installation recommendations.

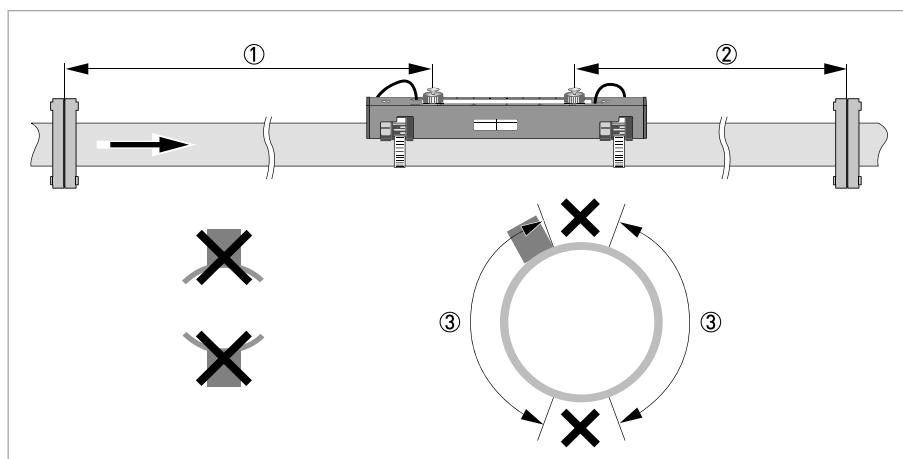

Figure 3-1: Inlet, outlet and recommended mounting area

- ① Min. 10 DN
- ② Min. 5 DN
- ③ Recommended installation location (120°)

Make sure that the rail is not mounted at the highest point (risk for air bubbles) or at the lowest point (risk for particles) of the pipe.

3.2.1 Horizontal (long) pipes

- Install on a slightly ascending pipe section or at the lowest point of the pipe system.
- Install air/gas release devices (air vent).
- If not possible, control the flow velocity to prevent gasses (air, gas or vapour) from collecting in the upper parts. In that case unwanted gasses are carried along with the flow continuously.
- In partially filled pipes, the clamp-on flowmeter will report incorrect or no flow rates.

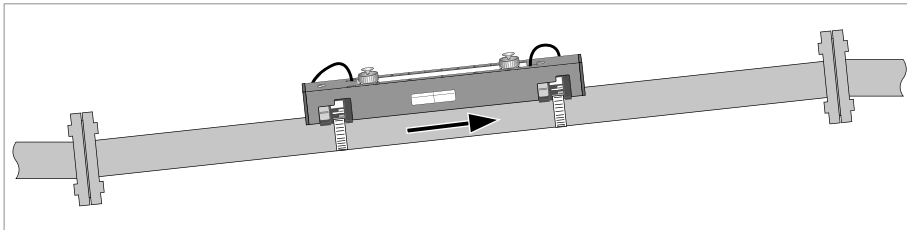

Figure 3-2: Install on a slightly ascending pipe section

3.2.2 Bends in 2 or 3 dimensions

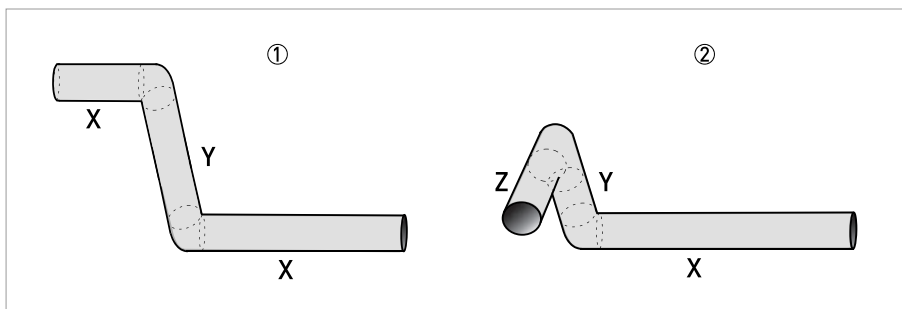

Figure 3-3: 2 and/or 3 dimensional bends upstream of the flowmeter

① 2 dimensions = X/Y

② 3 dimensions = X/Y/Z

Inlet length:

for 2 path using bends in 2 dimensions: ≥ 10 DN; when having bends in 3 dimensions: ≥ 15 DN

for 1 path using bends in 2 dimensions: ≥ 20 DN; when having bends in 3 dimensions: ≥ 25 DN

*2 dimensional bends occur in a vertical **or** horizontal plane (X/Y) only, while 3 dimensional bends occur in both vertical **and** horizontal plane (X/Y/Z).*

3.2.3 T-section

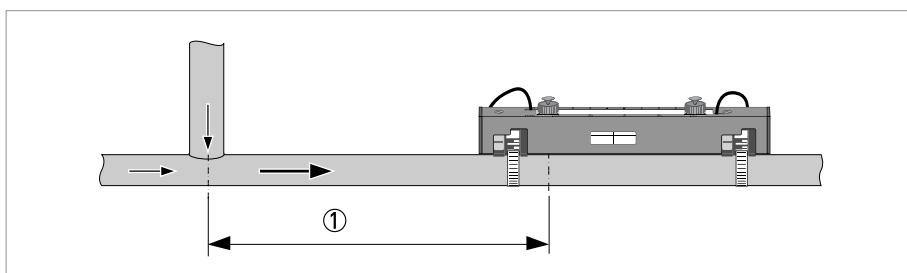

Figure 3-4: Distance behind a T-section

① ≥ 20 DN

3.2.4 Open feed or discharge

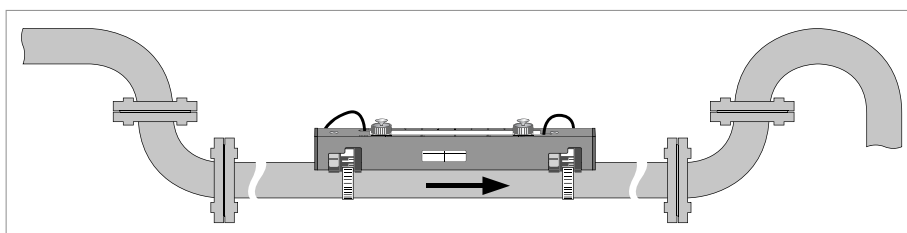

Figure 3-5: Open feed or discharge

Install the flowmeter on a lowered section of the pipeline to ensure a full pipe condition through the meter.

3.2.5 Bends

- Ensure that the pipe is fully filled at all times.
- Both ascending and descending flow direction is measurable.
- Observe the required in- and outlets.

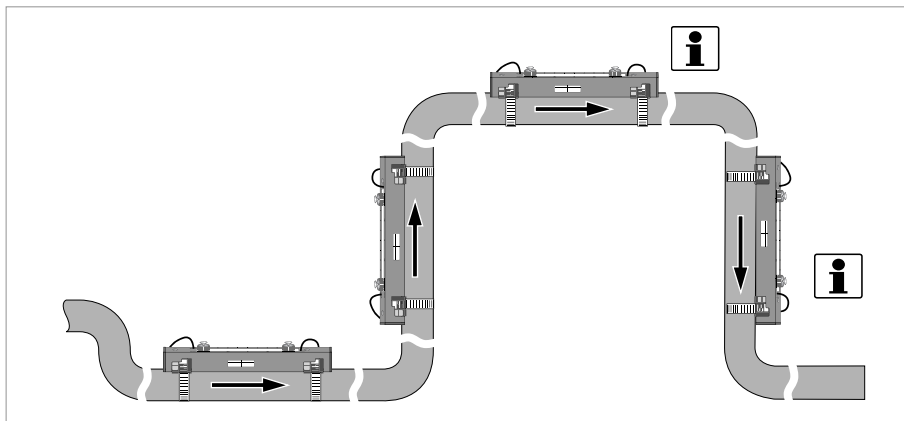

Figure 3-6: Mounting on vertical pipelines is possible

NOTE!

Recommended installation positions are at a lowered or ascending section of the pipeline installation. Installation at the highest point will enlarge the risk of flowmeter malfunction, because of air/gas bubbles.

Vertical installation in combination with an open discharge has to be avoided.
Vertical installation with a controlled back-pressure is possible.

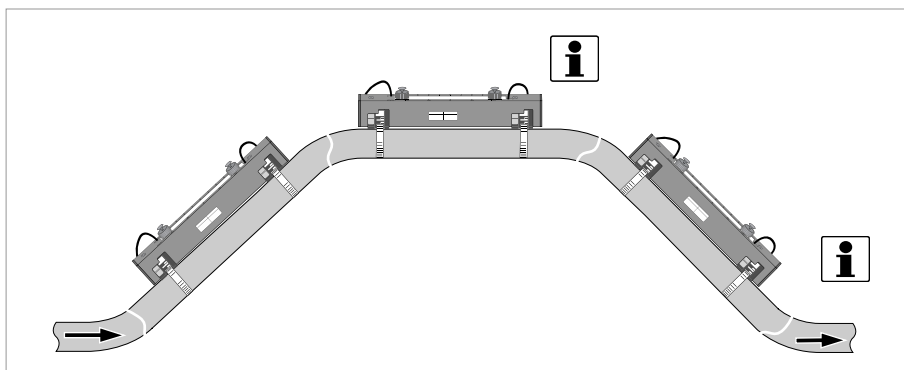

Figure 3-7: Mounting on ascending or descending pipelines is possible

NOTE!

Vertical installation on a descending slope in the pipeline is only recommended when the back-pressure is controlled.

3.2.7 Position of control valve

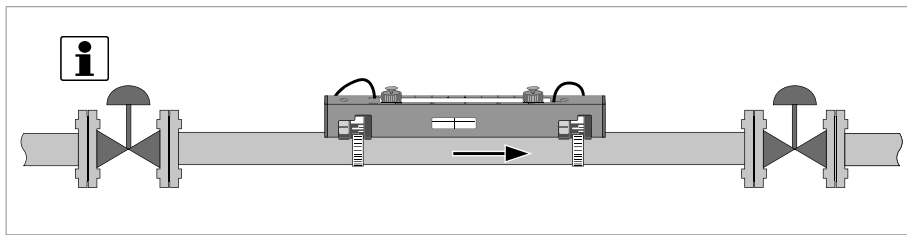

Figure 3-8: Position of control valve

NOTE!

Recommended position to install a flowmeter is upstream a control valve.

A clamp-on flowmeter can be installed downstream of the control valve if there is no cavitation in the pipeline system (e.g. flow profile disturbances are resolved).

3.2.8 Position of pump

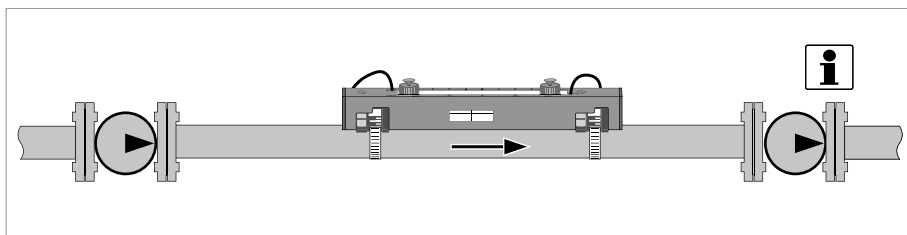

Figure 3-9: Position of pump

NOTE!

Recommended position to install a flowmeter is downstream a pump (on a position where the flow disturbances of the pump are resolved).

A clamp-on flowmeter can be installed in the suction line of a pump if there is no cavitation in the pipeline system.

3.3 Start up UFC 300 P signal converter

Charge the battery of the signal converter before first use and download and install the mobile application that is necessary to configure your measuring application.

The mobile application can be downloaded free of charge from the Google-Play website. The application is only available for Android devices.

Installing application

After downloading the application, make sure to adjust and set the following parameters on your mobile device:

- go to "Settings" / Wireless and networking / Tethering
- switch on Bluetooth Tethering
- set mobile connections to "Bluetooth"

Press the "On/Off button of the UFC 300 P converter for approximately 3 seconds to initialise the converter and establish connection with your device.



Figure 3-11: Keys UFC 300 P of signal converter

- ① Charging indication and battery status
- ② Indication of data exchange and connection
- ③ On/Off button and status LED

In case Bluetooth operation is not used, you can choose for the wired USB connection. Connect the I/O cable with USB to the Android mobile or tablet to maintain communication.

Transducer types

The following transducer types, diameter ranges and traverse modes are possible:

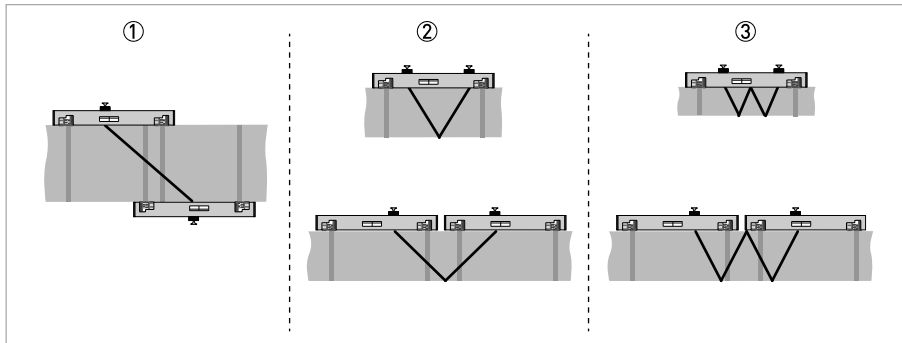

Figure 3-12: Number of traverses

- ① 1 traverse (Z mode)
- ② 2 traverses (V mode)
- ③ 4 traverses (W mode)

The best suitable configuration is made from the available transducer sets and selected automatically in the converter. The measurement mode and number of traverses are selectable in the following screen (screen).

The message "You must select a transducer set" will show when no transducer set is selected or suitable.

| Nominal diameter | Transducer type | Recommended traverse mode | Optional traverse mode | |
|------------------------|------------------------|---------------------------|------------------------|--|
| DN15...50/ ½...2" | Small 2 MHz, 1 rail | | | |
| DN50...150/ 2...6" | Small 2 MHz, 1 rail | | | |
| DN50...250/ 2...10" | Medium 1 MHz, 1 rail | | | |
| DN200...750/ 8...30" | Medium 1 MHz, 2 rails | | | |
| DN400...1500/ 16...60" | Medium 1 MHz, 2 rails | | | |
| DN200...2000/ 8...80" | Large 500 kHz, 2 rails | | | |
| DN200...4000/ 8...160" | Large 500 kHz, 2 rails | | | |

In standard and ideal applications with clean liquids and smooth pipe surfaces, install the transducer(s) and the rail(s) as advised. If the signal strength is not high enough, we recommend shortening the path length by decreasing the number of traverses or switching to a transducer type with a lower frequency.

For each installation, there is an "ideal transducer distance". Advice will follow for the theoretical transducer distance using the installation wizard.

Use two transducers mounted in one rail for transducer distances smaller than 190 mm / 7.5". For transducer distances of more than 190 mm / 7.5", two separate rails are used, with a transducer mounted on each rail.

| Advised distance [mm] | Number of rails needed |
|-----------------------|------------------------|
| < 190 | 1 |
| ≥ 190 | 2 |

INFORMATION!

The maximum distance that can be covered with 1 rail is 195 mm.

The minimum distance for two rails is 180 mm.

3.4 Step 3: Mount the sensor rails

Before mounting the rails, determine the colors on the connectors of the transducers. Make sure that the blue transducer is upstream and the green transducer is downstream. Consult the manual for more information

Installation with metal straps (DN15...250)

Put the metal straps around the pipe. Put the sensor rail(s) on the pipe including the transducers with fixed cables.

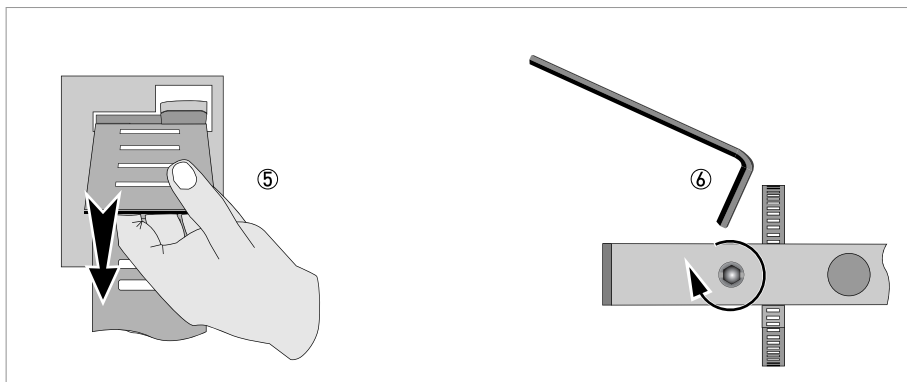
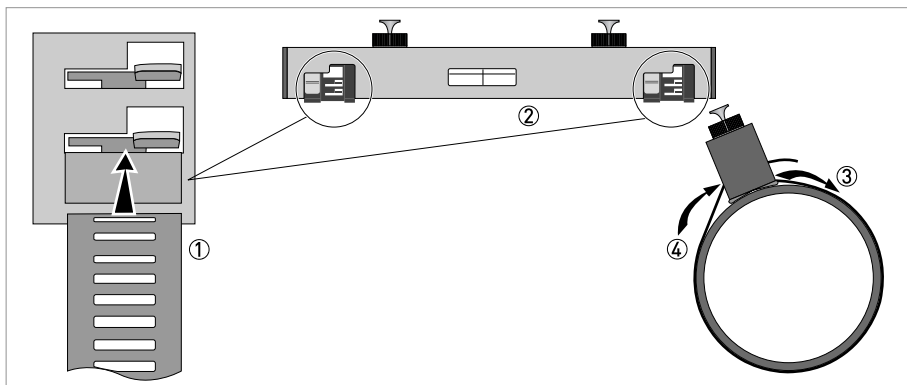

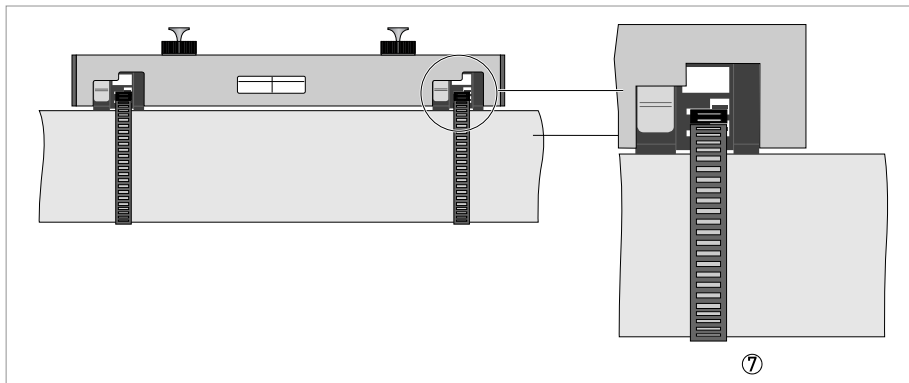

- ① Insert straps in the lower opening.
- ② Repeat the same for the other strap.
- ③ Pull the straps around the pipe.
- ④ Insert the straps in the upper opening.
- ⑤ Pull the straps tight.
- ⑥ Use an allen key nr 5 (or a big screwdriver) to fixate the rails.
- ➔ Detail ⑦ of the metal strap fixed in connector.

Installation with nylon straps (> DN250)

For pipe diameters above DN250 are available with different lengths.

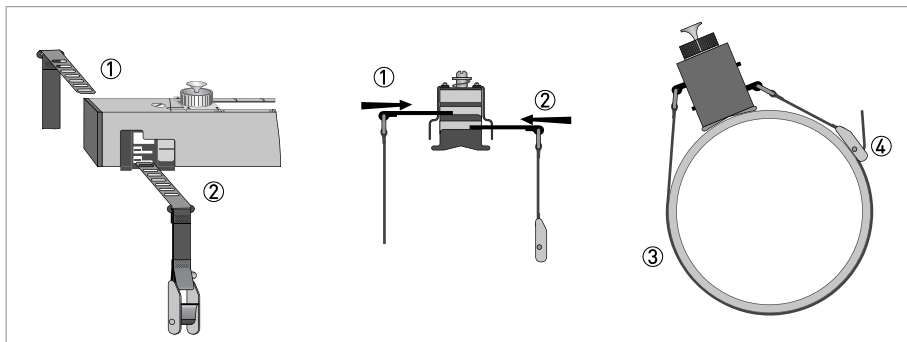

- ① Insert the long strap in the upper opening.
- ② Insert the short strap in the lower opening at the other side of the rail.
- ③ Pull the strap around the pipe.
- ④ Fix the strap, as indicated below.

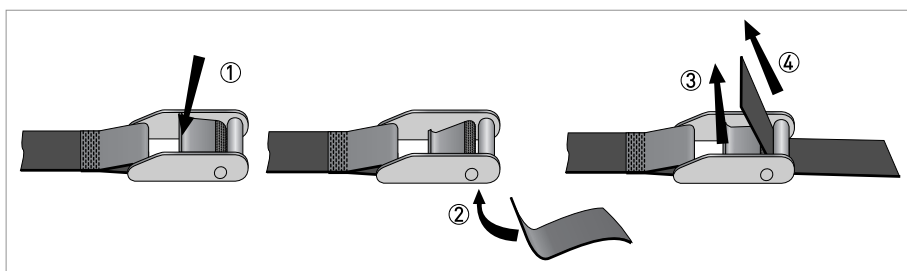

- ① Push lever to create an opening.
- ② Insert the nylon strap as indicated.
- ③ Release lever.
- ④ Pull strap tight.

3.5 Connect the sensor cable

The transducers have a 3 m/ 9.8 ft fixed signal cable with blue and green marked connectors for easy, correct and safe connection with the converter. Colour marked 7 m/ 22,9 ft extension cables with connectors are optionally available.

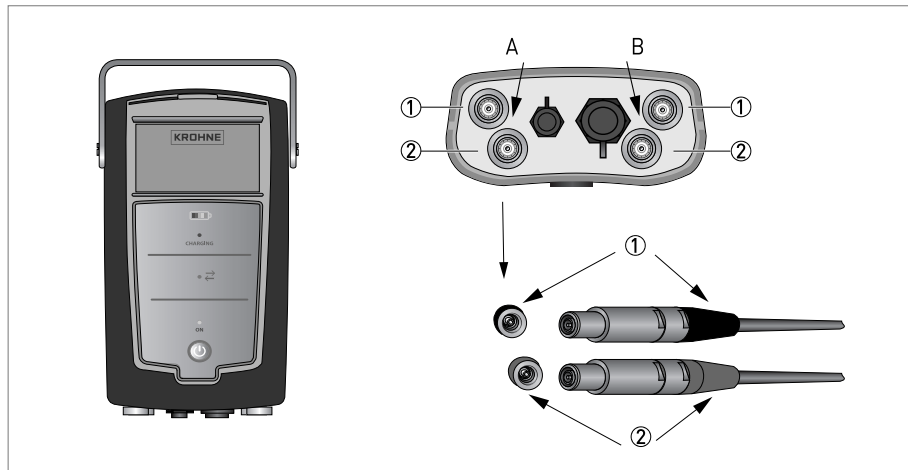

Figure 3-13: Connecting signal cables channel A and B

- ① Connector for "UP" transducer (blue)
- ② Connector for "DOWN" transducer (green)

In the mobile application, the flow signal strength is given and can be qualified as shown:

| Flow signal strength | Qualification |
|----------------------|--|
| > 75% | High signal |
| 50...75% | Fairly high signal |
| 10...50% | Low signal |
| < 10% | Bad or no signal |
| | Check settings in menu, change transducer distance until there is at least a low signal. |

- Continue the configuration in the mobile application and follow the advised settings and actions.

4.1 Safety instructions

*All work on the electrical connections may only be carried out with the power disconnected.
Take note of the voltage data on the nameplate!*

Observe the national regulations for electrical installations!

*Observe without fail the local occupational health and safety regulations.
Any work done on the electrical components of the measuring device may only be carried out by
properly trained specialists.*

*Look at the device nameplate to ensure that the device is delivered according to your order.
Check for the correct supply voltage printed on the nameplate.*

4.2 Power supply

Only use the original supplied AC/DC power supply adaptor!

*The battery status indicator will be accurate after an initial full discharge directly followed by a
full charge of the battery.*

The battery of the signal converter has to be fully charged before first use!
The rechargeable battery pack is not replaceable by the user.

*The product is externally evaluated for a maximum ambient temperature of 40°C / 104°F
(without derating) and 60°C / 140°F (50% derating), a maximum altitude of 3000 /
9843 feet meters and at an overvoltage category II environment.*

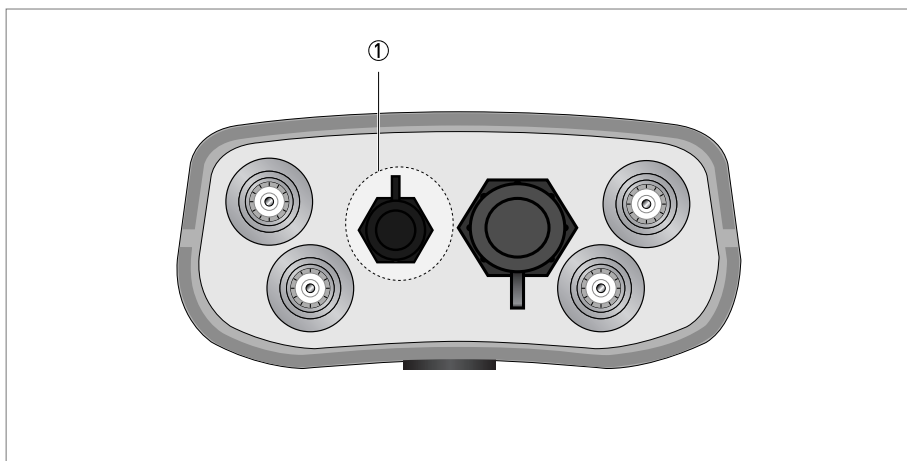

Figure 4-1: ① Connection 12 VDC power supply input

Switching on and off

The converter has an automatic switch-on functionality when connected to the mains. A switch-off is not possible during a connection.

In case the converter has to be switched off, the mains power has to be disconnected.

If the converter operates on battery power, the device is turned on/off by pressing the ON button for 3 seconds.

- Plug in the connector of the power adaptor cable into the DC connector ①
- Select your exchangeable AC power plug adapter (EU, UK, US, AUS) according to the mains outlet socket and plug it tightly onto the power adapter.
- Then insert the AC power connector into your mains outlet.

Charging in the car via the accessory plug

The flow converter can be charged via the 12 VDC accessory socket in the car.

*Only charge the battery when the ambient temperature is within the specified temperature range, refer to Technical data on page 10. **Avoid direct sunlight.** When the ambient temperature is not within the specified temperature range, the battery-charging current decreases to save the battery life span.*

- Connect the cable with the 12 VDC car accessory plug to the power input of the flow converter.
- Connect the car accessory plug into the 12 VDC socket of the car.

4.3 Connection of the signal cables

Find the calibration numbers that are noted on the labels on the cable of each transducer. Make sure that both transducers have the same calibration number as shown by the converter.

The signal cables are prefixed to the transducers in the factory.

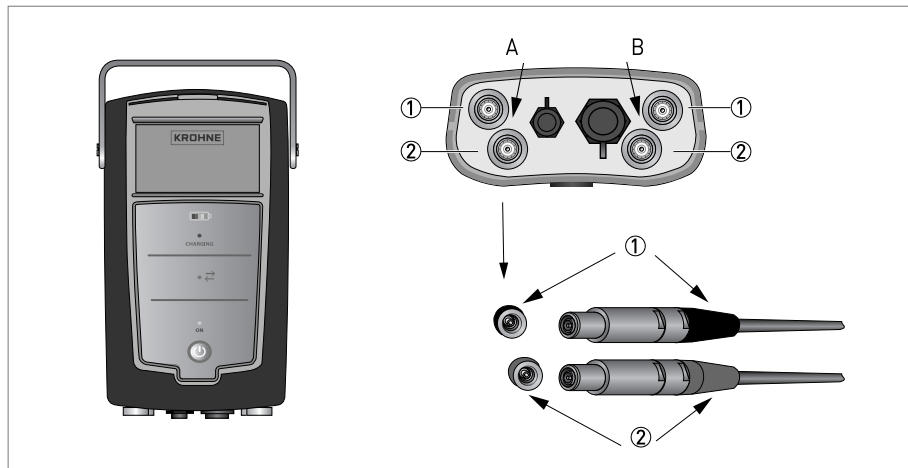

Figure 4-2: Connecting signal cables channel A and B

- ① Connector for "UP" transducer (blue)
- ② Connector for "DOWN" transducer (green)

The flow converter can measure two paths (A and B) simultaneously. Use the left pair of connectors ① and ② for path A and the right pair connectors ① and ② for path B.

4.4 Connection diagrams

| | |
|---|---|
|  | <p>mA meter 0...20 mA or 4...20 mA and other R_L is the internal resistance of the measuring point including the cable resistance</p> |
|  | <p>DC voltage source (U_{ext}), external power supply, any connection polarity</p> |
|  | <p>DC voltage source (U_{ext}), observe connection polarity according to connection diagrams</p> |
|  | <p>Internal DC voltage source</p> |
|  | <p>Controlled internal power source in the device</p> |
|  | <p>Electronic or electromagnetic counter At frequencies above 100 Hz, shielded cables must be used to connect the counters. R_i Internal resistance of the counter</p> |
|  | <p>Button, NO contact or similar</p> |

Table 4-1: Description of symbols

Basic inputs/outputs

CAUTION!

Observe connection polarity.
Not galvanically isolated.

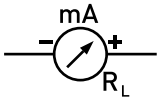
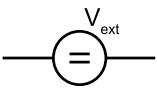
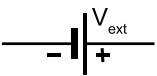
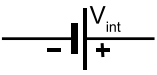
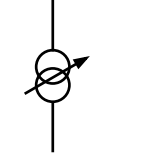
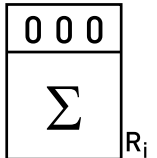
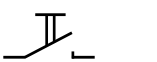
Current output active, basic I/Os (4...20 mA)

- $V_{\text{int, nom}} = 15 \text{ VDC}$ nominal
- $I \leq 22 \text{ mA}$
- $R_L \leq 1 \text{ k}\Omega$

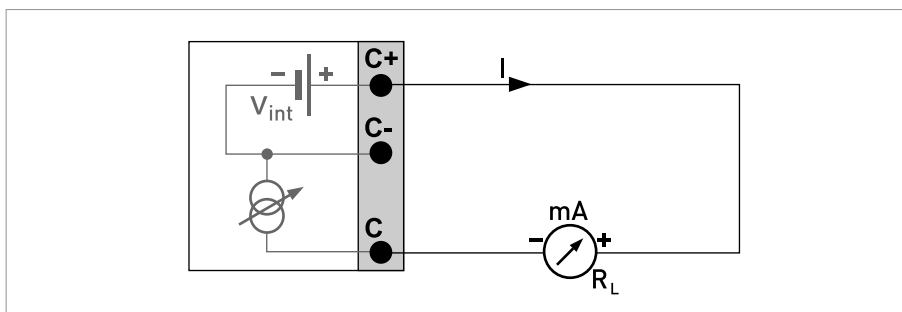

Figure 5-4: Current output active I_a

Current output passive, basic I/Os

- $V_{\text{int, nom}} = 15 \text{ VDC}$ nominal
- $V_{\text{ext}} \leq 32 \text{ VDC}$
- $I \leq 22 \text{ mA}$
- $V_0 \geq 1.8 \text{ V}$
- $R_L \leq (V_{\text{ext}} - V_0) / I_{\text{max}}$

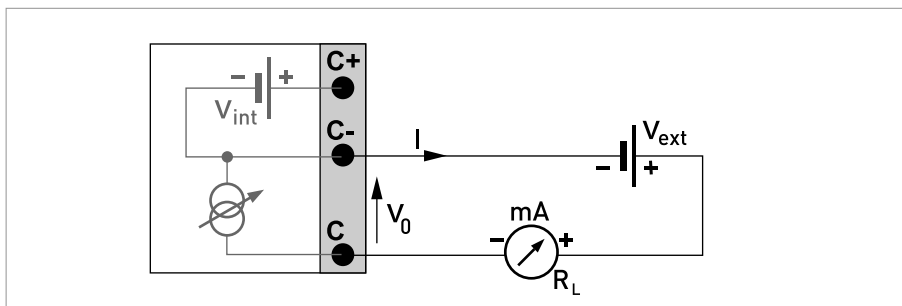

Figure 5-5: Current output passive I_p

INFORMATION!

- Any connection polarity.
- Galvanically isolated.
- At frequencies above 100 Hz, shielded cables must be used to reduce electrical interferences (EMC).

Pulse/frequency output passive, basic I/Os

- $V_{\text{ext}} \leq 32 \text{ VDC}$
- f_{max} in operating menu set to $f_{\text{max}} \leq 100 \text{ Hz}$:
 $I \leq 100 \text{ mA}$
open:
 $I \leq 0.05 \text{ mA}$ at $U_{\text{ext}} = 32 \text{ VDC}$
closed:
 $V_{0, \text{max}} = 0.2 \text{ V}$ at $I \leq 10 \text{ mA}$
 $V_{0, \text{max}} = 2 \text{ V}$ at $I \leq 100 \text{ mA}$
- f_{max} in the operating menu set to $100 \text{ Hz} < f_{\text{max}} \leq 10 \text{ kHz}$:
 $I \leq 20 \text{ mA}$
open:
 $I \leq 0.05 \text{ mA}$ at $V_{\text{ext}} = 32 \text{ VDC}$
closed:
 $V_{0, \text{max}} = 1.5 \text{ V}$ at $I \leq 1 \text{ mA}$
 $V_{0, \text{max}} = 2.5 \text{ V}$ at $I \leq 10 \text{ mA}$
 $V_{0, \text{max}} = 5.0 \text{ V}$ at $I \leq 20 \text{ mA}$
- If the following maximum load resistance $R_{L, \text{max}}$ is exceeded, the load resistance R_L must be reduced accordingly by parallel connection of R :
 $f \leq 100 \text{ Hz}$: $R_{L, \text{max}} = 47 \text{ k}\Omega$
 $f \leq 1 \text{ kHz}$: $R_{L, \text{max}} = 10 \text{ k}\Omega$
 $f \leq 10 \text{ kHz}$: $R_{L, \text{max}} = 1 \text{ k}\Omega$
- The minimum load resistance $R_{L, \text{min}}$ is calculated as follows:
 $R_{L, \text{min}} = (V_{\text{ext}} - V_0) / I_{\text{max}}$
- Can also be set as a status output; for the electrical connection, see status output connection diagram.

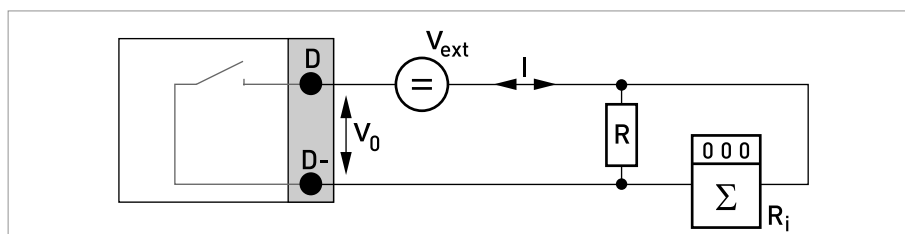
Figure 5-6: Pulse frequency output passive P_p

Pulse/frequency output active, basic I/Os

- $V_{nom} = 15 \text{ VDC}$
- f_{max} in operating menu set to $f_{max} \leq 100 \text{ Hz}$:
 $I \leq 20 \text{ mA}$
open:
 $I \leq 0.05 \text{ mA}$
closed:
 $V_{0, nom} = 15 \text{ V}$ at $I = 20 \text{ mA}$
- f_{max} in the operating menu set to $100 \text{ Hz} < f_{max} \leq 10 \text{ kHz}$:
 $I \leq 20 \text{ mA}$
open:
 $I \leq 0.05 \text{ mA}$
closed:
 $V_{0, nom} = 13.5 \text{ V}$ at $I \leq 1 \text{ mA}$
 $V_{0, nom} = 12.5 \text{ V}$ at $I \leq 10 \text{ mA}$
 $V_{0, nom} = 9.0 \text{ V}$ at $I \leq 20 \text{ mA}$
- If the following maximum load resistance $R_{L, max}$ is exceeded, the load resistance R_L must be reduced accordingly by parallel connection of R :
 $f \leq 100 \text{ Hz}$: $R_{L, max} = 47 \text{ k}\Omega$
 $f \leq 1 \text{ kHz}$: $R_{L, max} = 10 \text{ k}\Omega$
 $f \leq 10 \text{ kHz}$: $R_{L, max} = 1 \text{ k}\Omega$
- The minimum load resistance $R_{L, min}$ is calculated as follows:
 $R_{L, min} = (U_{ext} - U_0) / I_{max}$

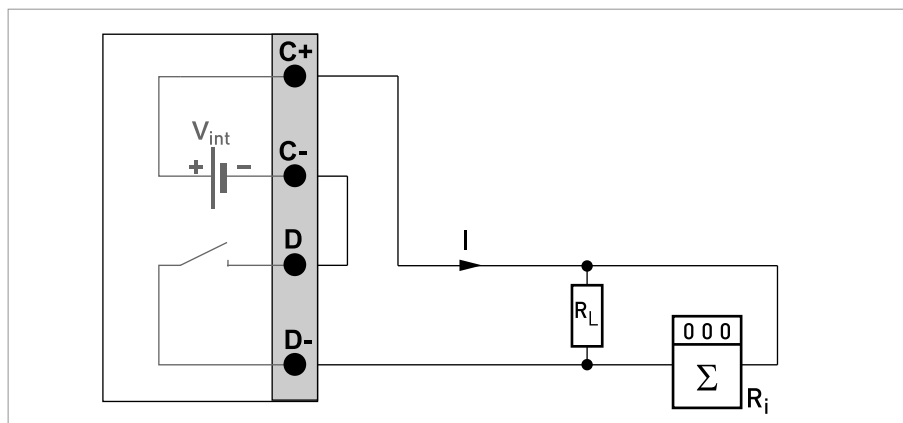
Figure 5-7: Pulse/frequency output active P_a

INFORMATION!

- Any connection polarity.
- Galvanically isolated.
- At frequencies above 100 Hz, shielded cables must be used to reduce electrical interferences (EMC).

Status output / limit switch passive, basic I/Os

- $V_{\text{ext}} \leq 32 \text{ VDC}$
- $I \leq 100 \text{ mA}$
- $R_{L, \text{max}} = 47 \text{ k}\Omega$
 $R_{L, \text{min}} = (V_{\text{ext}} - V_0) / I_{\text{max}}$
- open:
 $I \leq 0.05 \text{ mA}$ at $V_{\text{ext}} = 32 \text{ VDC}$
closed:
 $V_{0, \text{max}} = 0.2 \text{ V}$ at $I \leq 10 \text{ mA}$
 $V_{0, \text{max}} = 2 \text{ V}$ at $I \leq 100 \text{ mA}$
- The output is open when the device is de-energized.

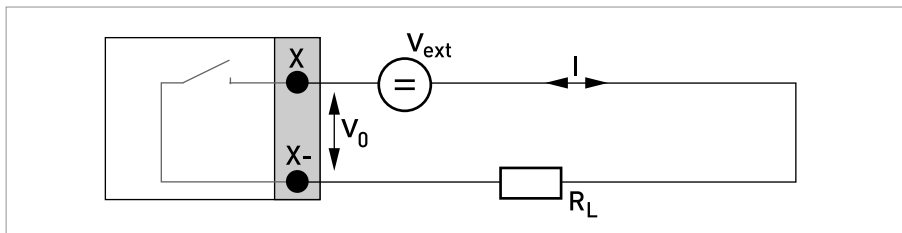
Figure 5-8: Status output / limit switch passive S_p **Current input active**

- $V_{\text{int, nom}} = 15 \text{ VDC}$
- $I \leq 22 \text{ mA}$
- $I_{\text{max}} \leq 26 \text{ mA}$ (electronically limited)
- $V_{0, \text{min}} = 9 \text{ V}$ at $I \leq 22 \text{ mA}$
- no HART®
- Not galvanically isolated
- X designates the connection terminals A or B, depending on the version of the signal converter.

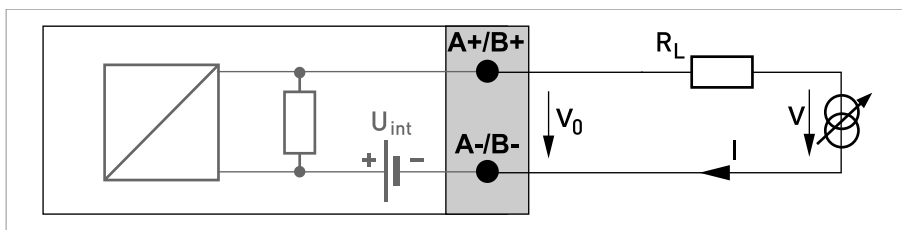
Figure 5-9: Current input active II_{n_a}

- ① Signal
- ② 2-wire transmitter (e.g. temperature)

Please fill in this form and include a sketch of the pipe layout with the X, Y, Z dimensions accordingly. Then fax or email it to your local representative.

Customer information

| | |
|---------------|--|
| Date: | |
| Submitted by: | |
| Company: | |
| Address: | |
| Telephone: | |
| Fax: | |
| E-mail: | |

Flow application data

| | |
|---|--|
| Reference information (name, tag etc) | |
| New application Existing application, currently using: | |
| Measurement objective: | |
| Fluid: | |
| Flow rate | |
| Normal: | |
| Minimum: | |
| Maximum: | |
| Temperature | |
| Normal: | |
| Minimum: | |
| Maximum: | |
| Viscosity | |
| Normal: | |
| Maximum: | |
| Continuous / pulsating flow. Description: | |
| Entrained air percentage (volume): | |
| Entrained solids percentage (volume): | |
| Emulsion present (e.g. oil / water): | |
| Emulsion percentage product A: | |
| Emulsion percentage product B: | |

Piping details

| | |
|--|--|
| Nominal pipe size: | |
| Outer diameter: | |
| Wall thickness / schedule: | |
| Pipe material: | |
| Pipe condition (old / new / painted / internal scaling / exterior rust): | |
| Liner material: | |
| Liner thickness: | |
| Straight inlet / outlet section (DN): | |
| Upstream situation (elbows, valves, pumps): | |
| Flow orientation (vertical up / horizontal / vertical down / other): | |

Environment details

| | |
|-------------------------|--|
| Corrosive atmosphere: | |
| Sea water: | |
| High humidity (% R.H.): | |
| Nuclear (radiation): | |
| Hazardous area: | |
| Additional details: | |

Hardware requirements:

| | |
|---|--|
| Accuracy requested (percentage of rate): | |
| Power supply (voltage, AC / DC): | |
| Analog output (4-20 mA): | |
| Pulse (specify minimum pulse width, pulse value): | |
| Digital protocol: | |
| Options: | |
| Remote mounted signal converter: specify cable length: | |
| Accessories: | |

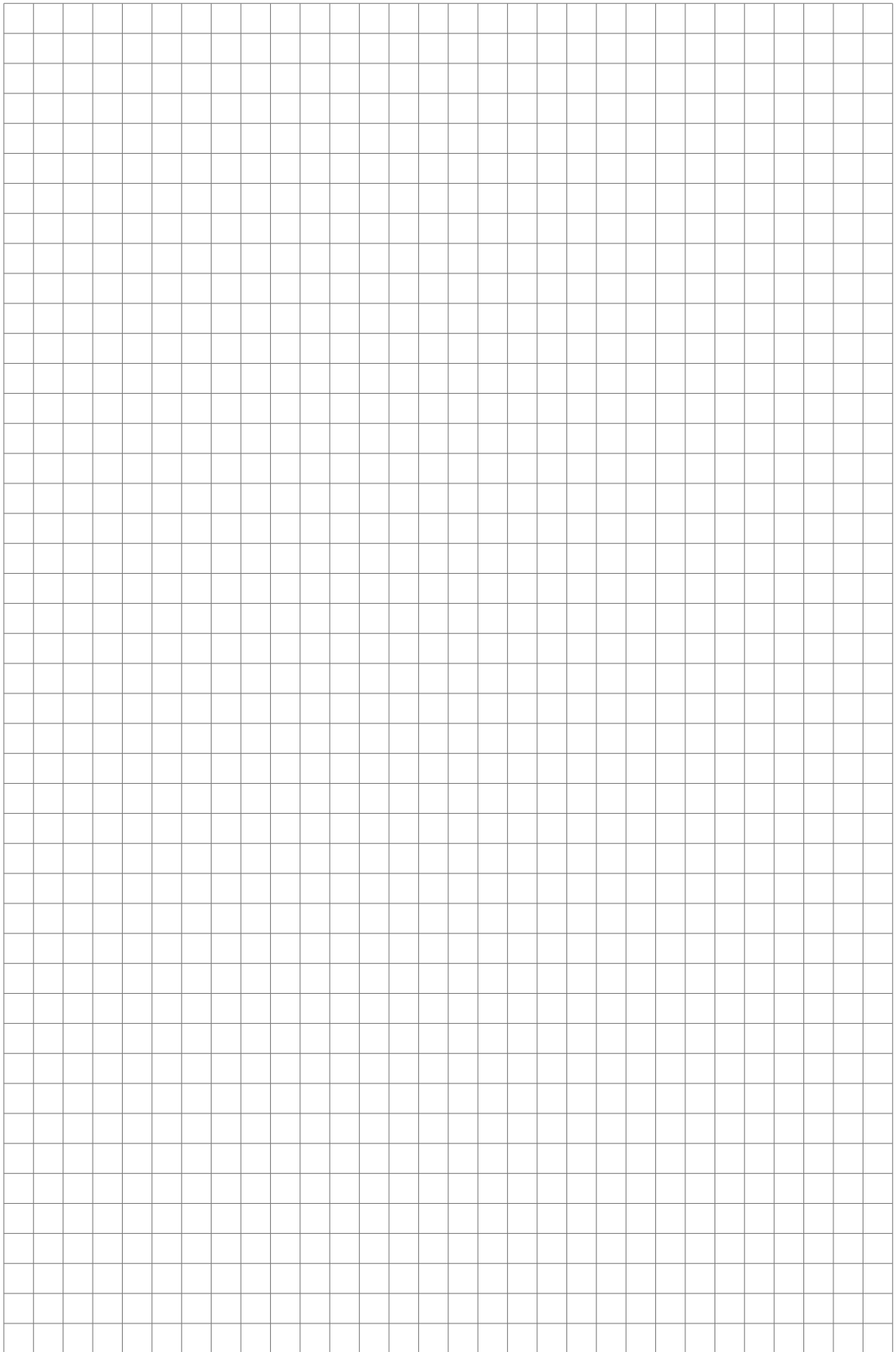

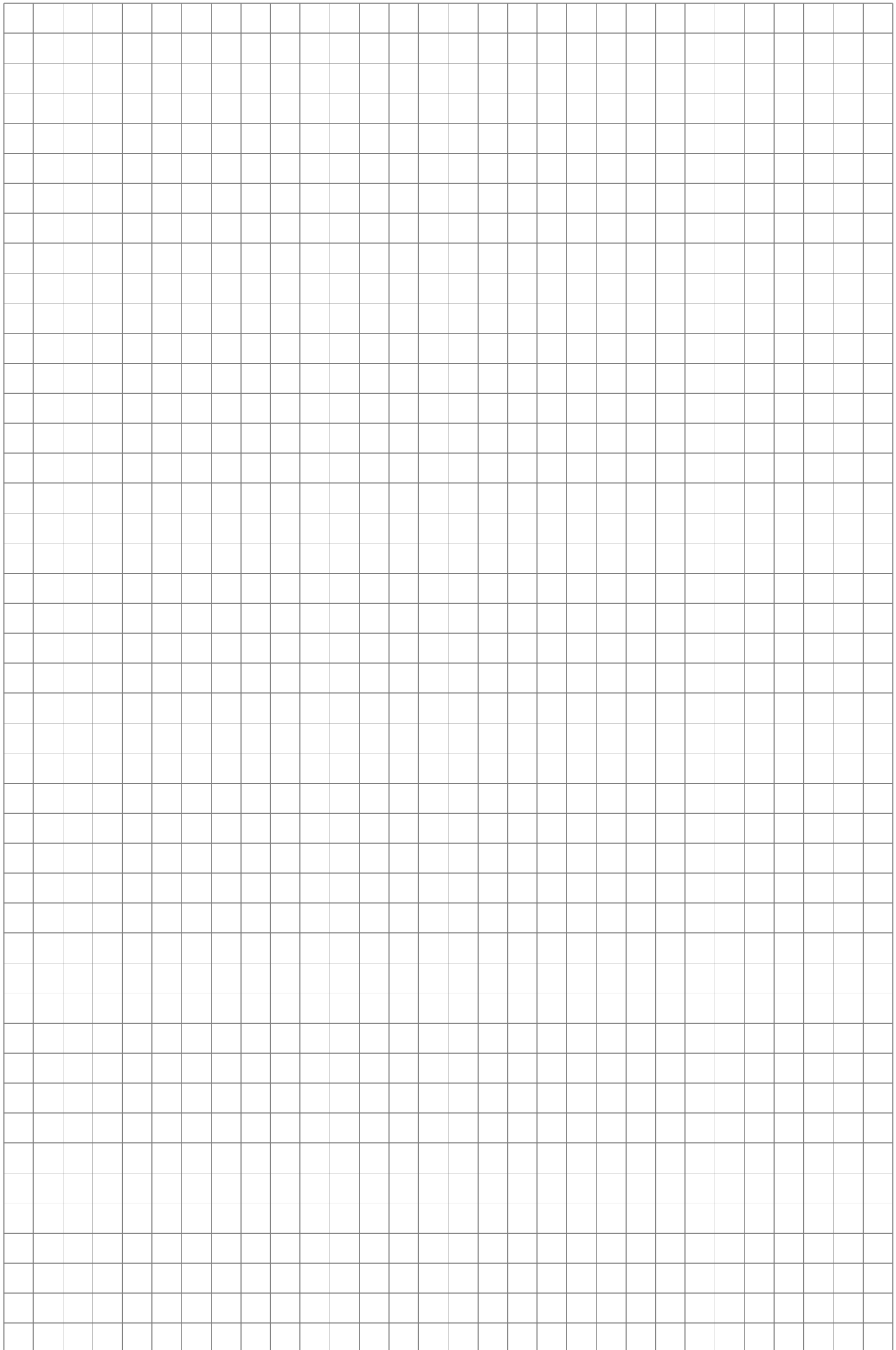

KROHNE – Products, Solutions and Services

- Process instrumentation for flow, level, temperature, pressure measurement and process analytics
- Flow metering, monitoring, wireless and remote metering solutions
- Engineering, commissioning, calibration, maintenance and training services

Head Office KROHNE Messtechnik GmbH
Ludwig-Krohne-Str. 5
47058 Duisburg (Germany)
Tel.: +49 203 301 0
Fax: +49 203 301 10389
info@krohne.de

The current list of all KROHNE contacts and addresses can be found at:
www.krohne.com

