



ALTAIR® Pro Single Gas Detector

Operating Manual



In North America, to contact your nearest stocking location, dial toll-free 1-800-MSA-2222
To contact MSA International, dial 724-776-8626 or 1-800-MSA-7777

© MINE SAFETY APPLIANCES COMPANY 2011 - All Rights Reserved

This manual is available on the internet at www.msanet.com

Manufactured by

MSA NORTH AMERICA

1000 Cranberry Woods Drive, Cranberry Township, Pennsylvania 16066

⚠ WARNING

THIS MANUAL MUST BE CAREFULLY READ BY ALL INDIVIDUALS WHO HAVE OR WILL HAVE THE RESPONSIBILITY FOR USING OR SERVICING THE PRODUCT. Like any piece of complex equipment, this instrument will perform as designed only if it is used and serviced in accordance with the manufacturer's instructions. OTHERWISE, IT COULD FAIL TO PERFORM AS DESIGNED AND PERSONS WHO RELY ON THIS PRODUCT FOR THEIR SAFETY COULD SUSTAIN SEVERE PERSONAL INJURY OR LOSS OF LIFE.

The warranties made by Mine Safety Appliances Company with respect to the product are voided if the product is not used and serviced in accordance with the instructions in this manual. Please protect yourself and others by following them. We encourage our customers to write or call regarding this equipment prior to use or for any additional information relative to use or repairs.

Table of Contents

Chapter 1, Instrument Safety and Certifications1-1

- Certifications1-2
 - Figure 2-1. ALTAIR Pro Overview2-1
 - Figure 2-2. ALTAIR Pro Display2-1

Chapter 2, Using the ALTAIR Pro Single Gas Detector .2-1

- Changing Alarm Setpoints2-2
 - To Change Alarm Setpoints Manually:2-2
 - Figure 2-3. ALTAIR Pro Setup2-4
- Turning ON the ALTAIR Pro Single Gas Detector2-5
 - Figure 2-4. ALTAIR Pro Turn-On Flow Chart2-7
- Battery Life Indicator (See FIGURE 2-2)2-8
- Battery Warning2-8
 - ▲ CAUTION2-8
- Confidence Indicator (see Figure 2-2)2-9
- Backlight2-9
- ALTAIR Pro Alarms2-9
 - Toxic Gas Measurements (see figure 2-1)2-9
 - ▲ WARNING2-9
- Oxygen Measurements2-11
 - ▲ WARNING2-11
- Accessing the Instrument Pages2-12
 - For All Versions (Excluding the Steel Mill Version): . .2-12
 - Steel Mill Version Only:2-14
 - Turning OFF the ALTAIR Pro Detector2-15
 - Figure 2-5. Accessing ALTAIR Pro Pages
(Does not apply to the Steel Mill Version) . .2-16
- Data Logging2-17
 - Session Log2-17
 - Periodic Log2-17

Chapter 3, ALTAIR Pro Function Checks3-1

Confidence and Heartbeat Indicator	3-1
Alarm Test	3-1
Bump Test	3-1
Figure 3-1. Bump Test Flow Chart	3-2
Table 3-1. Factory Set Default Calibration/Bump Test Values	3-3
▲ WARNING	4-1

Chapter 4, Calibrating the ALTAIR Pro Single Gas Detector4-1

Calibrating the Toxic Gas Instruments	4-2
▲ CAUTION	4-2
▲ WARNING	4-3
Figure 4-1. Calibration (Toxics) Flow Chart	4-4
Calibrating an Oxygen Instrument	4-5
Figure 4-2 Calibration (Oxygen) Flow Chart	4-6

Chapter 5, Warranty, Maintenance, & Troubleshooting .5-1

MSA Portable Instrument Warranty	5-1
Troubleshooting	5-2
▲ WARNING	5-2
Table 5-1. Troubleshooting Guidelines	5-3
Repair Procedures	5-4
Replacing the ALTAIR Pro Battery	5-4
Replacing the ALTAIR Pro Sensor (Except Remote O ₂ Version)	5-4
▲ CAUTION	5-4
▲ CAUTION	5-4
▲ CAUTION	5-5
▲ CAUTION	5-5
▲ WARNING	5-5
Figure 5-1. Sensor and Battery Replacement (Except Remote O ₂ Version)	5-5

**Chapter 6,
Performance Specifications6-1**

Table 6-1. Certifications6-1

Table 6-2. Instrument Specifications6-2

Table 6-3. Oxygen

 Typical Performance Specifications6-3

Table 6-4. Toxic Performance Specifications6-3

Table 6-5. Data Logging Specifications6-4

**Chapter 7,
Replacement and Accessory Parts7-1**

Table 7-1. Replacement Parts List7-1

Chapter 1, Instrument Safety and Certifications

The ALTAIR Pro Single Gas Detector is:

- For use by trained, qualified personnel
- Designed to be used when performing a hazard assessment to determine the appropriate gas monitoring needed for a workplace.
- To be used when performing a hazard assessment to:
 - Assess potential worker exposure to Specific toxic gases for which a sensor is installed
 - Oxygen-deficient or oxygen-rich atmospheres for oxygen versions only

NOTE: Although the ALTAIR Pro O₂ unit will detect up to 25% oxygen, all ALTAIR Pro versions are not certified or classified for use in atmospheres containing more than 21.0% oxygen.

WARNING

- **Read and follow all instructions carefully.**
- **Do not use this detector to sample the instrument's specified gas in gases other than air.**
- **Perform an alarm function check and a bump test before each day's use. If the instrument fails either check, the instrument must be taken out of service.**
- **Recheck response and alarm function if the instrument is subjected to physical shock.**
- **Do not alter this instrument or make repairs beyond those specified in this manual. Only MSA-authorized personnel may repair this unit; otherwise, damage may result.**
- **This unit contains a lithium battery; dispose of according to local regulations.**
- **Wait for an accurate reading; response times vary, based on the gas being detected.**
- **Use only to detect a gas for which a sensor is installed.**
- **Do not block sensor.**
- **Leave area immediately if a gas alarm condition is reached.**

- Do not use pressurized air to clean the sensor or alarm holes.
- All instrument readings and information must be interpreted by someone trained and qualified in interpreting instrument readings in relation to the specific environment, industrial practice and exposure limitations.
- ALTAIR Pro Detector's gas sensors may have a cross-sensitivity response to common interference gases other than the gas it is designed to detect. In some cases, this cross-sensitivity may be positive, producing a reading higher than actual. In other cases, it may be negative, giving lower readings or even negative. Contact MSA for further details if cross-sensitivity may be an issue.
- • Conditions for Safe Use:
 - When it is necessary to replace the battery, use only a Lithium battery listed in TABLE 6-2.

**INCORRECT USE OR FAILURE TO FOLLOW THIS WARNING
CAN RESULT IN SERIOUS PERSONAL INJURY OR DEATH.**

Certifications

The ALTAIR Pro Single Gas Detector meets applicable industry and government standards as indicated on the instrument Approval label and specified in TABLE 6-1.

Chapter 2, Using the ALTAIR Pro Single Gas Detector

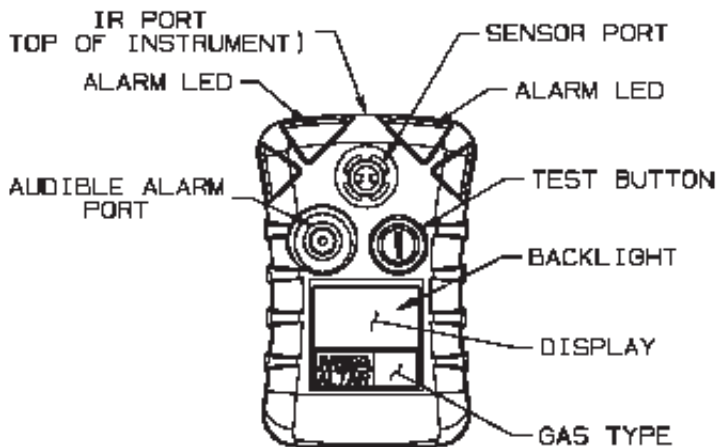

Figure 2-1. ALTAIR Pro Overview

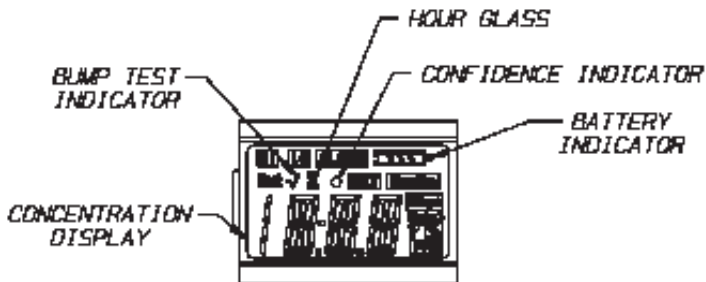

Figure 2-2. ALTAIR Pro Display

Changing Alarm Setpoints

NOTE: Alarm setpoints can only be changed manually during instrument setup, which can be entered after battery attachment or reattachment. See FIGURE 2-3 for details. Alarm setpoints can also be changed electronically using the the MSA FiveStar® LINK® Software. The latest software version can be downloaded from the MSA webpage (www.msanet.com).

To Change Alarm Setpoints Manually:

1. Ensure instrument is turned OFF before proceeding.
2. Remove and re-attach battery.
3. Turn instrument ON.

The unit must be turned ON before it can be used to warn the user of a potentially hazardous condition.

- a. To turn ON the personal protection instrument, press and hold the "TEST" button for three seconds.
 - "ON" displays during this time period.

NOTE: The Steel Mill version cannot be turned OFF without removing the battery.

4. "ALARM", "SET", "?" displays for three seconds.
5. To change the alarm setpoints manually, press the button once while "ALARM", "SET", "?" displays.

NOTE: If the TEST button is not pressed, the instrument turns ON, as usual, after three seconds.

6. The Software Version displays for three seconds
7. The gas type displays for three seconds.
["CO", "CO+" (steel mill version), "H₂S", or "O₂", etc.].
8. Alarm Setpoints are displayed:

- **Low Alarm Setpoint** for three seconds
 - LO and ALARM icons turn ON
 - a. To change the low alarm setpoint, press the TEST button when "LO" "ALARM" displays:
 - "LO" "ALARM" "SET" "?" displays.
 - b. Press the TEST button in rapid succession to increment the *low* alarm value.

- The TEST button can be held down to increment by larger amounts.
- c. Once the correct value displays, release the TEST button and wait three seconds to continue.
- **High Alarm Setpoint** for three seconds
 - HI and ALARM icons turn-ON
 - a. To change the high alarm setpoint, press the TEST button when "HI" "ALARM" displays:
 - "HI" "ALARM" "SET" "?" displays
 - b. Press the TEST button in rapid succession to increment the *high* alarm value.
 - The TEST button can be held down to increment by larger amounts.
 - c. Once the correct value displays, release the TEST button and wait three seconds to continue.
- **Short Term Exposure Limits, "STL"**, displays; then, the STEL setpoint displays for three seconds.
 - a. To change the STEL setpoint, press the "TEST" button when the setpoint displays.
 - "ALARM""SET", "?" displays.
 - b. Press the TEST button in rapid succession to increment the STEL alarm value.
 - The TEST button can be held down to increment the STEL alarm value.
 - c. Once the desired value displays, release the TEST button and wait three seconds to continue.
- **Time Weighted Average, "TWA"**, displays; then, the TWA setpoint displays for three seconds.
 - a. To change the TWA setpoint, press the "TEST" button when the setpoint displays.
 - "ALARM""SET", "?" displays.
 - b. Press the TEST button in rapid succession to increment the TWA alarm value.
 - The TEST button can be held down to increment the TWA alarm value.
 - c. Once the desired value displays, release the TEST button and wait three seconds to continue.

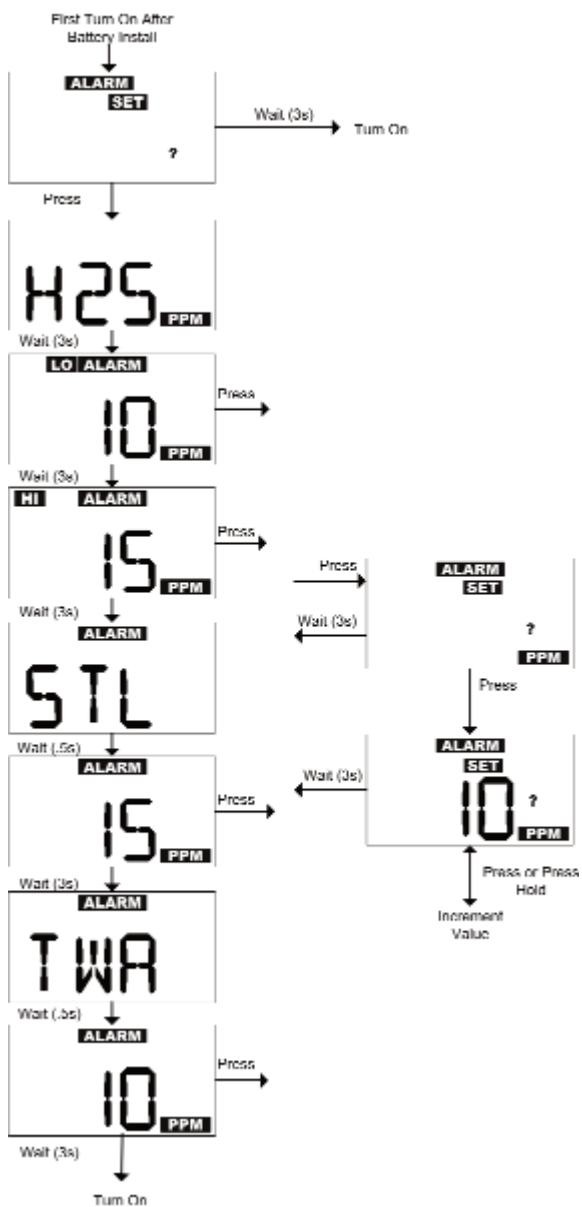

Figure 2-3. ALTAIR Pro Setup

Turning ON the ALTAIR Pro Single Gas Detector

1. The unit must be turned ON before it can be used to warn the user of a potentially hazardous condition.
 - a. To turn ON the personal protection instrument, press and hold the TEST button for three seconds.
 - "ON" displays during this time period.

NOTE: The Steel Mill version cannot be turned OFF without removing the battery or using FiveStar LINK software. The latest software version can be downloaded from the MSA webpage (www.msanet.com).

2. The following occurs:
 - an LCD Functional Test activates the cell segments
 - the horn, LEDs and vibrator also activate.
3. The Software Version displays for three seconds.
4. The instrument gas type displays for three seconds ("CO", "H₂S", or "O₂", etc.).
5. Alarm Setpoints display the:
 - **Low Alarm Setpoint** for three seconds
 - "LO" and "ALARM" icons turn ON
 - **High Alarm Setpoint** for three seconds
 - "HI" and "ALARM" icons turn ON
6. Short Term Exposure Limit, STL, and the "ALARM" icon display, followed by the STL alarm setpoint for three seconds.
7. Time Weighted Average, TWA, and the "ALARM" icon displays, followed by the TWA alarm setpoint display for three seconds.
8. If Calibration Due (CAL DUE) is enabled via FiveStar LINK software (default is OFF):
 - "CAL" and the hourglass display.

NOTE: See FIGURE 2-4 for details.
 - If calibration is due, "DUE" and the hourglass display for three seconds.
 - The instrument beeps and flashes "CAL" "DUE" every minute until instrument calibration is performed.
 - If calibration is not due, the hourglass, number of days to calibration, and "DAYS" display.

9. User is prompted for a Fresh Air Setup (FAS):

- "SET", "?" icon and FAS display.

If Fresh Air Setup is desired, immediately press the TEST button.

- "HOURLASS", "SET", and FAS display.

If user does *not* desire FAS, do NOT press the TEST button:

- The instrument continues the ON sequence.

NOTE: When performing a fresh air setup, the instrument must be in a known clean air. The fresh air setup has limits.

If a hazardous level of gas is present, the ALTAIR Pro instrument displays "FAS / ERR".

Press the TEST button to acknowledge the error. and perform an instrument calibration.

10. If the instrument was configured for Oxygen, it displays:

- Oxygen reading
- % icon
- battery indicator.

If the instrument is configured for a toxic gas, it displays:

- gas reading
- PPM icon
- battery indicator.

Battery Life Indicator (See FIGURE 2-2)

- The battery condition icon continuously displays in the upper right-hand corner of the display.
- As the battery is depleted, battery icon segments go blank until only the outline of the battery icon remains.
 - Each battery indicator segment represents approximately 1/4 of the total battery capacity.

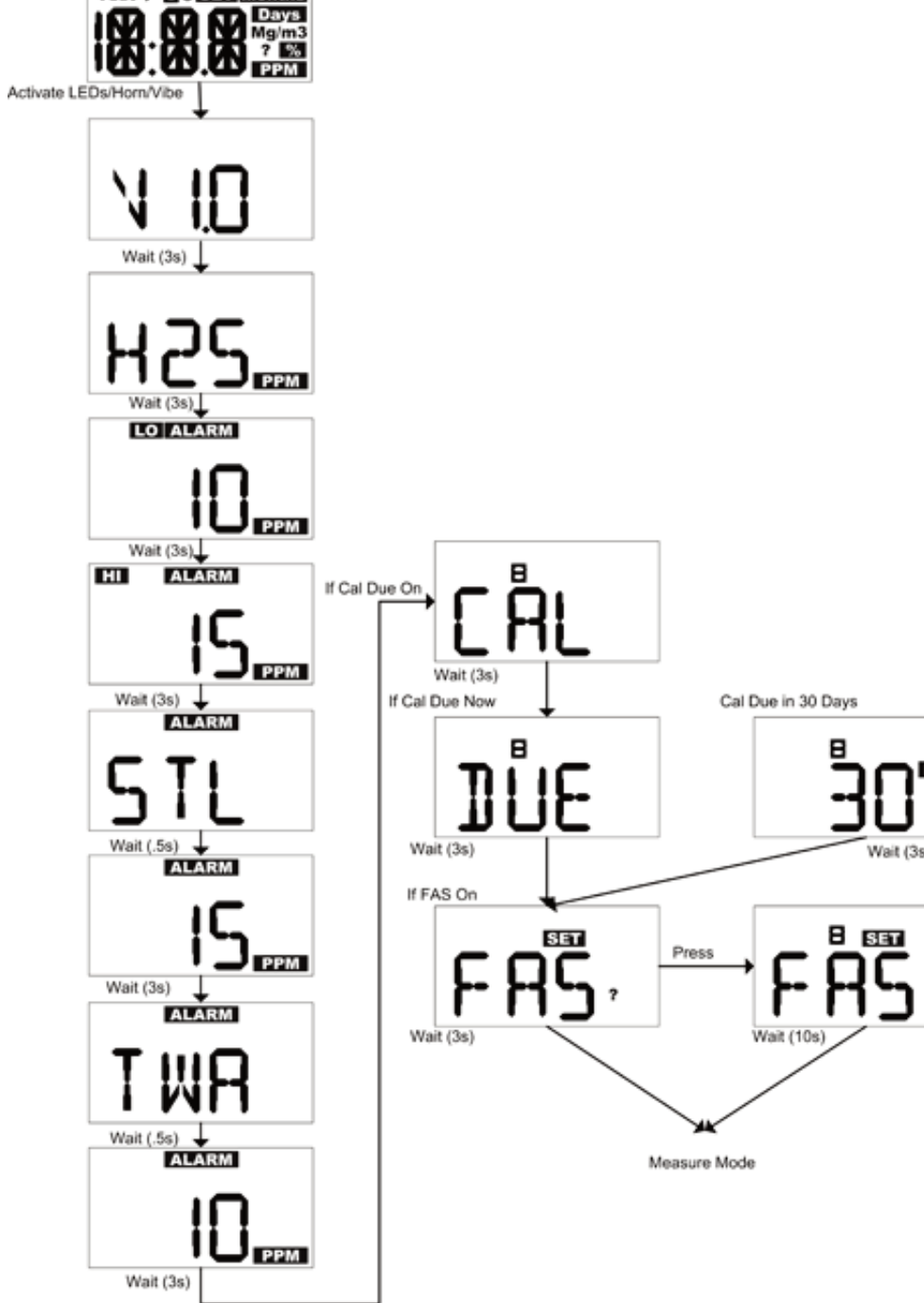

Figure 2-4. ALTAIR Pro Turn-ON Flow Chart

Battery Warning

- A battery warning indicates that a nominal two days of operation remain before the instrument's battery is depleted.

NOTE: The duration of remaining instrument operation during battery warning depends on:

- Ambient temperature (Colder temperatures may reduce battery life)
- The number and duration of alarms during battery warning.
- When the ALTAIR Pro unit goes into battery warning the:
 - Battery outline indicator flashes
 - Audible alarm sounds every 30 seconds
 - Alarm lights flash every 30 seconds.

CAUTION

During Battery Warning condition, prepare to exit the work area since the instrument could go into battery Shutdown at any time, resulting in loss of sensor function.

Battery Shutdown

- When the battery can no longer operate the instrument, the instrument goes into Battery Shutdown mode:
 - Battery outline indicator flashes
 - Alarm icon turns ON
 - Alarm sounds every 30 seconds
 - Alarm lights flash
 - No gas reading display
 - Display alternates between "BAT" and "ERR"
 - No other instrument pages can be viewed
 - The instrument remains in this state until it is:
 - Turned OFF or
 - Battery is completely depleted.
- The alarm lights and the horn can be silenced by pushing the TEST button.

WARNING

If a Battery Shutdown condition occurs, stop using the instrument and leave the area immediately. The instrument can no longer alert you of potential hazards since it does not have enough power to operate properly.

Failure to follow this warning can result in serious personal injury or death.

- When the instrument battery is running low, remove it from service and replace the battery.

Confidence Indicator (see Figure 2-2)

- The Confidence indicator flashes once every 60 seconds to notify the user that the instrument is ON and operating normally. In addition, both LEDs will flash briefly every 60 seconds.

Backlight

- The backlight can be manually activated with a quick push of the TEST button.
- The backlight remains ON for 10 seconds.

ALTAIR Pro Alarms

Toxic Gas Measurements (see FIGURE 2-1)

The ALTAIR Pro Detector can be purchased to detect the following gases in the atmosphere:

- Carbon Monoxide (CO) or
- Phosphene (PH₃)
- Hydrogen Cyanide (HCN)
- Chlorine Dioxide (ClO₂).
- The ALTAIR Pro Detector displays the gas concentration in parts per million (PPM) on the measuring page.
 - The instrument remains on this page until another page is selected or the instrument is turned OFF.
- There are four alarm setpoints in the instrument:
 - High Alarm
 - Low Alarm
 - STEL Alarm
 - TWA Alarm
- The backlight turns ON for 20 seconds during an alarm condition.

1. If the gas concentration reaches or exceeds the low alarm setpoint:
 - The instrument will:
 - display and flash "LO" and "ALARM" on the LCD
 - enter a low alarm sequence.
 - The low alarm can be silenced for five seconds by pressing the TEST button; it automatically clears once the gas level falls below the setpoint.
2. If the gas concentration reaches or exceeds the high alarm setpoint:
 - The instrument will:
 - display and flash "HI" and "ALARM" on the LCD
 - enter a High alarm sequence.
 - The high alarm can be silenced for five seconds by pressing the TEST button while it is still in high alarm.
 - The High alarm is latching and will not reset when gas concentration falls below the HIGH setpoint.

NOTE: To reset alarm, push the TEST button after the gas level falls below the setpoint.
- Refer to the instrument during turn ON for factory-set alarm points.
- If a gas concentration exceeds an alarm setpoint, the:
 - Audible alarm sounds
 - Alarm lights flash
 - Vibrator activates
 - Alarm type displays, alternately flashing the ALARM icon and the:
 - LO icon (if the low alarm setpoint was exceeded)
 - HI icon (if the high alarm setpoint was exceeded).
3. If the STEL (Short Term Exposure Limit) reading reaches or exceeds the STEL alarm setpoint:
 - The instrument will:
 - display and flash "LO" AND "ALARM" on the LCD
 - Enter a Low alarm sequence.
 - The STEL alarm can be silenced for five seconds by pressing the TEST button while it is still in alarm
 - The STEL alarm is non-latching and will reset when STEL reading falls below the STEL setpoint
 - The STEL value can be cleared. (See FIGURE 2-5 for details.)

- The STEL alarm can be disabled using FiveStar LINK Software. The latest software version can be downloaded from the MSA webpage (www.msanet.com).
4. If the TWA (Time Weighted Average) reading reaches or exceeds the TWA alarm setpoint:
- The instrument will:
 - display and flash "LO" and "ALARM" on the LCD
 - Enter a Low Alarm sequence.
 - The TWA alarm can be silenced for five seconds by pressing the TEST button while it is still in alarm
 - The TWA alarm is latching and will not reset
 - The TWA value can be cleared. (See FIGURE 2-5 for details.)
 - The TWA alarm can be disabled using FiveStar LINK Software.
 - Refer to the instrument during Test mode for factory-set alarm setpoints.

⚠ WARNING

If a toxic or oxygen gas alarm condition is reached while using the instrument as a personal or area monitor, leave the area immediately: the ambient condition has reached a pre-set alarm level. Failure to follow this warning will cause over-exposure to toxic gases, which can result in serious personal injury or death.

Oxygen Measurements

- The ALTAIR Pro Detector can be purchased to measure the concentration of oxygen in an atmosphere.
 - The value displayed is percent by volume of oxygen in the atmosphere.
 - High and Low alarm setpoints can be configured to alarm in any combination of oxygen:
 - enrichment (greater than 20.8%) or
 - depletion (less than 20.8%).
- When an alarm setpoint is reached, the:
 - Audible alarm sounds
 - Alarm lights flash
 - Vibrator activates

- Type of alarm displays by alternately flashing the ALARM icon and the LO or HIGH icon, depending on how the Low and High alarms were set.
- Low Alarm indicates:
 - the lower %O₂ level of the two alarm settings
 - a more urgent condition and the faster alarm sequence will be indicated
 - "LO" "ALARM" displays.

NOTE: The LOW alarm (lower of the two %O₂ alarm settings) is latching and will not reset when O₂ concentration rises above the LOW setpoint.

- To reset alarm push the TEST button

False oxygen alarms can occur due to barometric pressure (altitude) changes or extreme changes in ambient temperature. It is recommended that an oxygen calibration be performed at the temperature and pressure of use. Be sure that the instrument is in known fresh air before performing a calibration.

Accessing the Instrument Pages

A single, quick button press turns ON the backlight for 10 seconds. The Information page can be accessed by pushing the TEST button for about one second.

- The instrument beeps twice.

For All Versions (Excluding the Steel Mill Version):

- 1) Test gas mode
- 2) Minimum Oxygen concentration ("LO") - for oxygen only
- 3) Peak Reading
 - Toxic ("HI")
 - Oxygen ("HI")
 - The Peak/Hi and Min/Low values can be cleared.
 - When this page is displayed, press the TEST button to clear.
 - "CLR" displays.
- 4) Short Term Exposure Limit, STL.
 - The STL reading displays that the instrument calculated since power-ON.
 - When this page displays, press the TEST button to clear.
 - "CLR" displays.
 - STEL is automatically reset to zero when the instrument is turned ON.
 - STEL value is calculated over a 15-minute exposure.
 - The following formula is used to calculate the STEL value:

$$\frac{(\text{Minute \#1 PPM value}) + (\text{Minute \#2 PPM value}) + \dots + (\text{minute \#15 PPM value})}{(15 \text{ minutes})} = \text{PPM STEL value}$$

- If the instrument is ON for less than 15 minutes:
 - the balance of the minute PPM values is set to zero and
 - the total is divided by 15 minutes.

5) Time Weighted Average, TWA.

- The TWA reading displays what the instrument has calculated since power-ON.
- When this page displays, press the TEST button to clear.
 - "CLR" displays
- TWA value is automatically reset to zero when the instrument is turned ON.
- TWA value is calculated over an eight-hour exposure
- The following formula is used to calculate the TWA value:
$$\text{Sum of 1-minute gas readings} / 480 \text{ minutes (8 hours)} = \text{TWA value}$$
- If the instrument is ON for less than 8 hours (480 minutes), the balance of the minute ppm values is set to zero,

6) IR mode.

- When instrument displays "IR?", press button to enter IR mode.
- If IR communications are not detected for three minutes or the TEST button is pressed, the instrument will exit this mode.
- See FIGURE 2-5 for additional details.

Steel Mill Version Only:

- 1) Test gas mode
- 2) Functional check of LCD, vibrator, LEDs and horn
- 3) Software version displays.
- 4) Gas type
- 5) Low Alarm setpoint ("LO" "Alarm")
- 6) High Alarm setpoint ("HI" "Alarm")
- 7) STL Alarm setpoint
- 8) TWA Alarm setpoint
- 9) Peak Reading
 - Toxic ("HI")
 - The Peak/Hi and Min/Low values can be cleared.
 - When this page is displayed, press the TEST button to clear.
 - "CLR" displays.
- 10) Short Term Exposure Limit, STL
 - The STL reading displays that the instrument calculated since power-ON.
 - When this page displays, press the TEST button to clear.
 - "CLR" displays.

- STEL is automatically reset to zero when the instrument is turned ON.
- STEL value is calculated over a 15-minute exposure.
- The following formula is used to calculate the STEL value:

$$\begin{aligned} & (\text{Minute \#1 PPM value}) + (\text{Minute \#2 PPM value}) + \dots \\ & (\text{minute \#15 PPM value}) / (15 \text{ minutes}) = \text{PPM STEL value} \end{aligned}$$

- If the instrument is ON for less than 15 minutes:
 - the balance of the minute PPM values is set to zero and
 - the total is divided by 15 minutes.

11) Time Weighted Average, TWA

- The TWA reading displays what the instrument has calculated since power-ON.
- When this page displays, press the TEST button to clear.
 - "CLR" displays
- TWA value is automatically reset to zero when the instrument is turned ON.
- TWA value is calculated over an eight-hour exposure
- The following formula is used to calculate the TWA value:

$$\text{Sum of 1-minute gas readings} / 480 \text{ minutes (8 hours)} = \text{TWA value}$$

- If the instrument is ON for less than 8 hours (480 minutes), the balance of the minute ppm values is set to zero,

12) IR mode.

- When instrument displays "IR?", press button to enter IR mode.
- If IR communications are not detected for three minutes or the TEST button is pressed, the instrument will exit this mode.
- See FIGURE 2-5 for additional details.

Turning OFF the ALTAIR Pro Detector

1. Press and hold the TEST button for three seconds.
 - "OFF" and the hourglass display.
2. Continue to press the TEST button for two more seconds.
 - The instrument turns OFF.

NOTE: The Steel Mill version can't be turned OFF without removing the battery.



**Figure 2-5. Accessing ALTAIR Pro Pages
(Does not apply to the Steel Mill Version)**

Data Logging

Session Log

- The ALTAIR Pro Single Gas instrument has the capability of recording 50 of the most recent events.

To transfer data to a pc, hold the TEST button for one second.

- The instrument pages begin to display.
- Put the instrument in IR mode (see FIGURE 2-5).
- Events will be transferred to the PC during this sequence, if:
 - the top of the instrument is pointed toward the optional IR Receiving device
 - a PC is running MSA FiveStar Link Software (P/N 710946)
 - "CONNECT" is pressed in the PC FiveStar LINK Software package.
- The following events are recorded:
 - Alarm - Alarm Type - Alarm Value - Time/Date
 - Alarm Clear - Alarm Type - Alarm Value - Time/Date
 - Cal (Pass/Fail) - Time/Date
 - Bump (Pass/Fail) - Time/Date
 - Error - Error Type (See Error List) - Time/Date

Periodic Log

- Peak gas readings are periodically logged, based on user settings via the PC. (Default is one sample every three minutes.)
- See TABLE 6-3 for typical performance.

NOTES:

- The time and date is based on the PC time and date. Ensure the PC is correct before communicating with the instrument.
- Changing the instrument battery can result in lost time in the Data log.
- After changing batteries, verify the Time and Date with your PC.

Chapter 3, ALTAIR Pro Function Checks

Confidence and Heartbeat Indicator

- The alarm lights and heartbeat indicator on the display will flash approximately every 60 seconds to indicate that the ALTAIR Pro Detector is operating.

Alarm Test

- Check before each day's use.
- Turn ON instrument. A one-second test of the alarms will occur; this includes the:
 - display
 - alarm lights
 - vibrator
 - horn.
- If these items do not activate, remove the instrument from service.

NOTE: For the Steel Mill version only, the alarm test occurs every time the button is pressed for one second.

Bump Test

- Check before each day's use.
- Hold the TEST button for two seconds:
 - oxygen versions will display the current oxygen reading; calibrate the unit if it reads other than 20.8%.
 - "TEST" "GAS" "?" will display.
- Press the TEST button while "TEST" "GAS" "?" displays to activate the Bump Test mode.
 - the hourglass and "GAS" will display.
- Apply gas only **AFTER** the hourglass and "GAS" are displayed.
 - If gas is detected, the display will indicate "OK".
- Wait approximately five seconds:
 - The "✓" that appears on the display:
 - indicates that the instrument passed the bump test.
 - remains for 24 hours, indicating that a bump test was performed on this instrument within the last 24 hours.

NOTE: See FIGURE 3-1 for details

- If the "✓" does not appear and "ERR" is indicated:
 - Check that the:
 - sensor inlet is not clogged
 - correct calibration cylinder is used to perform the bump test
 - gas cylinder has not expired and is not empty
 - gas was applied at the appropriate time
 - gas tubing is seated in the front instrument case during testing.
 - Repeat the bump test process as needed.
- If the "✓" does not appear, calibrate the instrument and repeat the Bump Test.

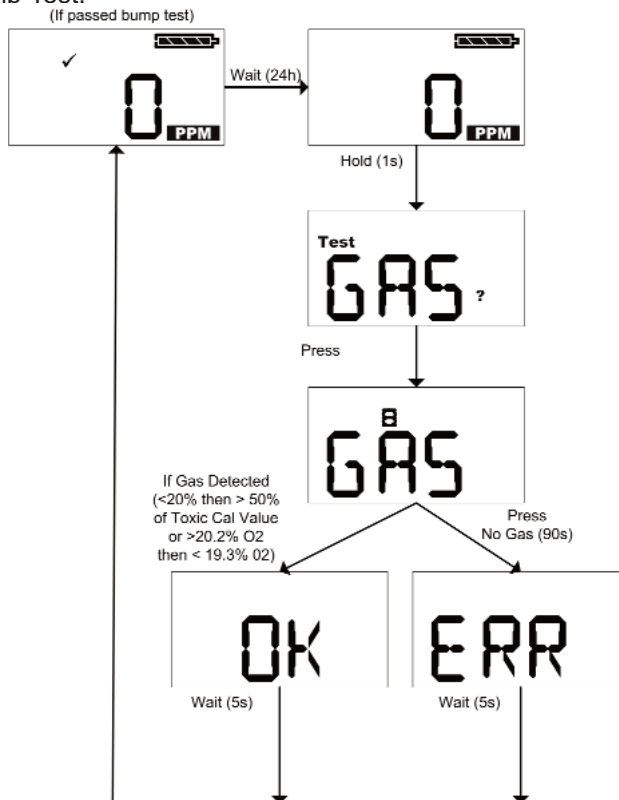

Figure 3-1. Bump Test Flow Chart

Table 3-1. Factory Set Default Calibration/Bump Test Values

INSTRUMENT TYPE	BUMP TEST GAS	CALIBRATION GAS
CO	60 ppm	60 ppm
O ₂	<19%*	20.8%
PH ₃	0.5 ppm	0.5 ppm
HCN	10 ppm	10 ppm
ClO ₂	2 ppm Cl ₂	0.8 ppm ClO ₂ **

* The O₂ bump test can also be performed by exhaling on the sensor inlet for approximately three to five seconds.

** MSA recommends calibration of the ClO₂ ALTAIR Pro Detector using a ClO₂ generator for most accurate calibration. This instrument has a cross-sensitivity factor to Cl₂ of: 2 ppm Cl₂ equals approximately 0.8 ppm ClO₂.

Chapter 4, Calibrating the ALTAIR Pro Single Gas Detector

⚠ WARNING

Regulators and tubing used for bump testing and calibrating ClO₂, HCN or PH₃ should be labeled by the user for that specific gas and must only be used for that gas exclusively in the future.

- The ALTAIR Pro Single Gas detector must be calibrated if it does not pass a Bump Test or if calibration is required by local procedures. In addition:
- For oxygen instruments, perform a calibration if:
 - there are changes in barometric pressure (altitude changes)
 - there are extreme changes in ambient temperature and humidity (see TABLE 6-2, "Instrument Specifications").
 - the instrument does not pass a bump test.
 - Calibration is required at certain intervals by local procedures.
- For toxic instruments, perform a calibration if any of the following occur:
 - physical shock
 - extended use in extreme temperatures
 - high concentration exposure
 - the instrument does not pass a bump test.
 - Calibration is required at certain intervals by local procedures.

Calibrating the Toxic Gas Instruments

⚠ CAUTION

Due to high reactivity of Cl_2 and ClO_2 , gas, ambient humidity and calibration tubing material can react with the gas and cause the concentration reading to be lower than the actual concentration. It is, therefore, necessary to use dry tubing when calibrating or bump checking with these gases. For best calibration, use the shortest possible tubing to connect to the calibration cylinder for these gases.

- To enter the calibration mode, make sure you are in fresh, uncontaminated air. See FIGURE 4-1 for more details.
- 1. In normal operating mode, hold the TEST button for two seconds.
 - "TEST" "GAS" "?" displays.
- 2. Press and hold the TEST button for three seconds when the "TEST" "GAS" "?" displays.
 - "TEST" "CAL" screen displays
 - After three seconds, "FAS" "?" displays asking the user if a fresh air setup/calibration is desired.
- 3. Press the TEST button to enter zero calibration.

NOTE: Otherwise, the instrument will return to the normal operating mode.

- 4. During zero calibration:
 - the hour glass and "FAS" display
 - If the instrument successfully calibrates:
 - "OK" displays
 - If the instrument does not successfully calibrate:
 - "ERR" displays
 - instrument returns to normal operating mode after five seconds.
- 5. Once the instrument successfully calibrates and the "OK" displays:
 - "CAL" "?" displays.
- 6. While the "CAL" "?" displays, press the TEST button to enter the Gas Calibration mode.
 - The current expected test gas is shown (in ppm).
 - a. To change the expected calibration gas:
 - 1) Press the TEST button.

- "TEST" "SET" "?" "ppm" displays.
- 2) Press the TEST button in rapid succession to increment.
 - The TEST button can be held down to increment by larger values..
 - 3) Wait three seconds to return to the Calibration mode.
- b. Apply the appropriate test gas
- The display toggles between the current gas reading, the hourglass and "CAL".
 - Once the instrument passes calibration, "OK" displays. Calibration time is dependent on the sensor installed. See TABLE 6-2.
 - Otherwise, "ERR" displays.
 - Wait five seconds to return to the normal operating mode.

▲ WARNING

The expected gas concentrations must match the gas concentrations listed on the calibration cylinder(s). Failure to follow this warning will cause an incorrect calibration, which can result in serious personal injury or death.

- c. If "ERR" displays after calibration, the current settings did not change. Immediately check that:
 - The calibration cylinder matches the expected calibration value expected in the instrument
 - The calibration cylinder is not empty and has not expired.
 - The regulator is 0.25 liters/minute
 - The tubing is seated in the front instrument case during gas calibration mode.
 - If necessary, repeat steps 1 through 6.
 - The display must read "OK"; if "ERR" remains, remove the instrument from service.
- d. Perform a bump test to confirm operation and activate the " $\sqrt{\text{ }}$ ".

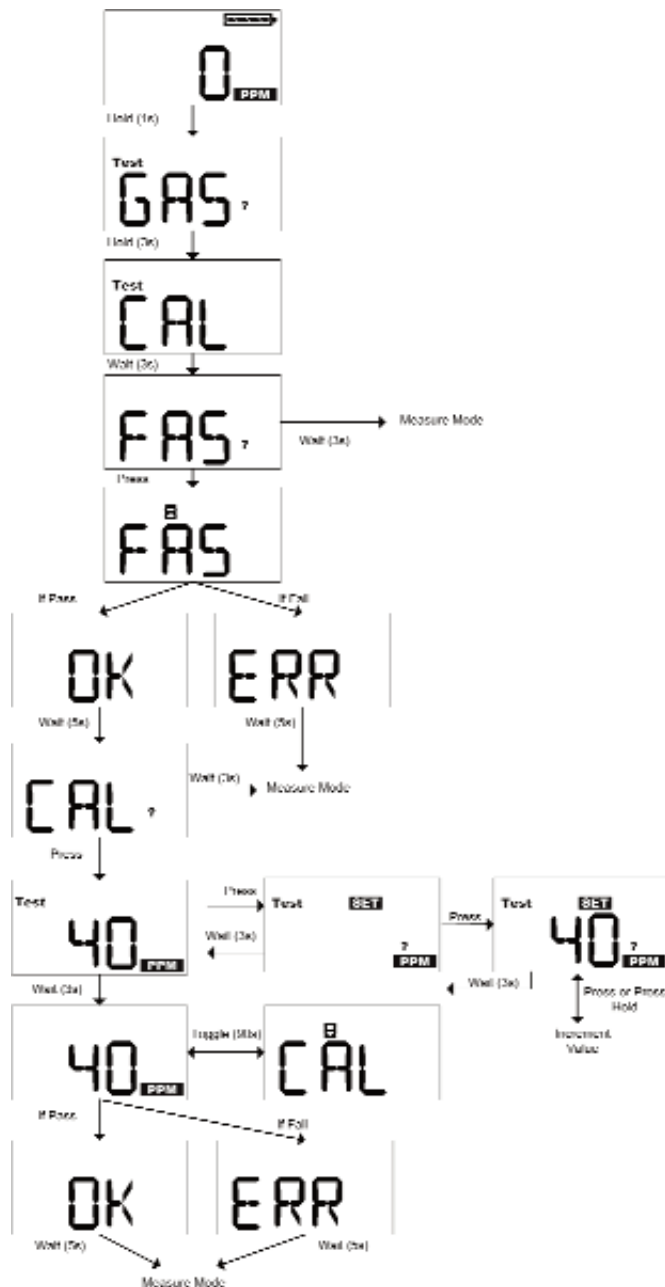

Figure 4-1. Calibration (Toxics) Flow Chart

Calibrating an Oxygen Instrument

- False oxygen alarms can occur due to changes in barometric pressure (altitude changes) or extreme changes in ambient temperature.
- The ALTAIR Pro Detector is equipped with a feature to allow calibration at pressure and/or temperature of use.
- Be sure that the instrument is in known fresh air before performing a calibration.

To enter the calibration mode, make sure you are in fresh, uncontaminated air.

1. In normal operating mode, hold the TEST button for two seconds.
 - See FIGURE 4-2 for more details.
2. When the "TEST" "GAS" "?" displays, press and hold the TEST button to enter calibration.
 - "TEST" "CAL" displays
 - After three seconds, "FAS" "?" displays asking the user if a fresh air setup/calibration is desired.
3. Press the TEST button at the "FAS" "?" screen to perform a calibration at 20.8% O₂.

NOTE: This procedure must be performed in fresh, uncontaminated air. Do not breathe on the sensor while performing this function.

- If the successfully calibrates:
 - "OK" displays
 - If the sensor does not successfully calibrate:
 - "ERR" displays.
4. Wait five seconds.
 - The instrument returns to normal operating mode.
 5. If "ERR" displays after calibration, the current settings did not change. Immediately check that:
 - The instrument is in fresh, uncontaminated air during the calibration process
 - No one breathes on the sensor during calibration.
 - Repeat steps 1 through 6, as necessary.
 6. The display must read "OK"; if "ERR" remains, remove the instrument from service.
 7. Perform a bump test to confirm operation and activate the "√".

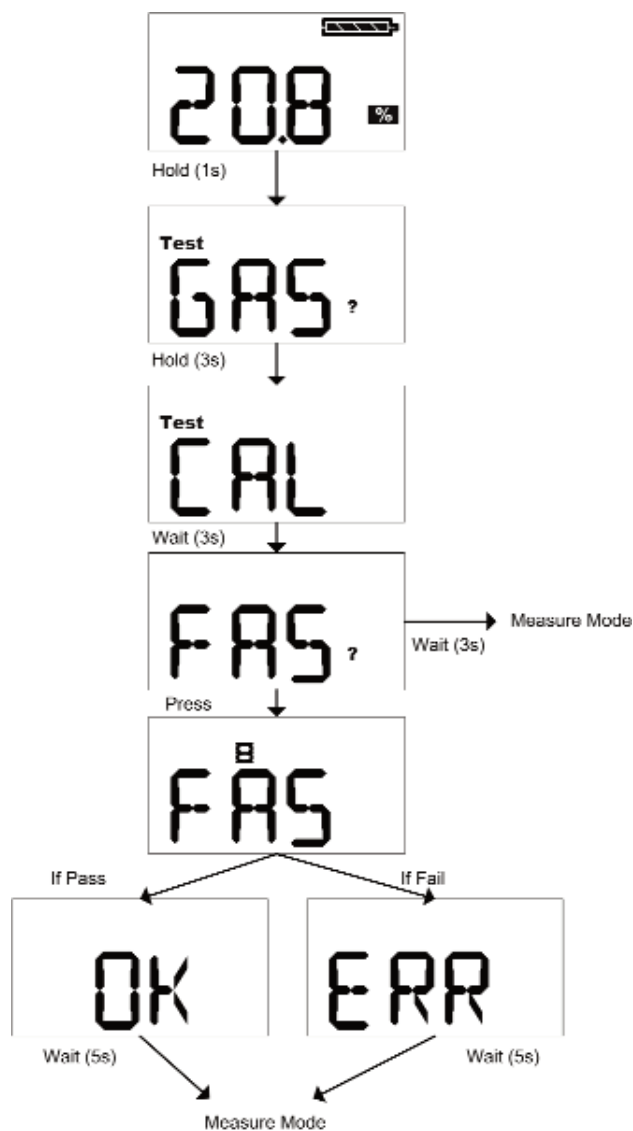

Figure 4-2 Calibration (Oxygen) Flow Chart

Chapter 5, Warranty, Maintenance, and Troubleshooting

MSA Portable Instrument Warranty

1. **Warranty** - MSA warrants that this product will be free from mechanical defects and faulty workmanship for a period of two (2) years from date the product is first used, provided it is maintained and used in accordance with MSA's instructions and/or recommendations. Warranty shall not exceed two years and six months from the date of manufacture. The instrument's battery is not covered under the warranty. The instrument's sensors are warranted for a period as described in the table below.

SENSORS	WARRANTY TERM
CO, CO Fire, CO Steel,	30 months from the date of manufacture or 24 months
H ₂ S, O ₂ , O ₂ -R	from the date of first use, whichever occurs first
SO ₂ , NO ₂ , NH ₃ , PH ₃ ,	18 months from the date of manufacture, or 12 months
HCN, Cl ₂ , ClO ₂	from the date of first use, whichever occurs first

MSA shall be released from all obligations under this warranty in the event repairs or modifications are made by persons other than its own or authorized service personnel or if the warranty claim results from physical abuse or misuse of the product. No agent, employee or representative of MSA has any authority to bind MSA to any affirmation, representation or warranty concerning the goods sold under this contract. THIS WARRANTY IS IN LIEU OF ALL OTHER WARRANTIES, EXPRESSED, IMPLIED OR STATUTORY, AND IS STRICTLY LIMITED TO THE TERMS HEREOF. SELLER SPECIFICALLY DISCLAIMS ANY WARRANTY OF MERCHANTABILITY OR OF FITNESS FOR A PARTICULAR PURPOSE.

2. **Exclusive Remedy** - It is expressly agreed that Purchaser's sole and exclusive remedy for breach of the above warranty, for any tortious conduct of MSA, or for any other cause of action, shall be the repair and/or replacement at MSA's option, of any equipment or parts thereof, which after examination by MSA is proven to be defective. Replacement equipment and/or parts will be provided at no cost to Purchaser, F.O.B. MSA's Plant. Failure of MSA to successfully repair any nonconforming product shall not cause the remedy established hereby to fail of its essential purpose.

3. **Exclusion of Consequential Damage - Purchaser specifically understands and agrees that under no circumstances will MSA be liable to Purchaser for economic, special, incidental or consequential damages or losses of any kind whatsoever, including but not limited to, loss of anticipated profits and any other loss caused by reason of non-operation of the goods. This exclusion is applicable to claims for breach of warranty, tortious conduct or any other cause of action against MSA.**

Troubleshooting

- The ALTAIR Pro Single Gas Detector will operate reliably when handled and maintained properly. If the instrument becomes inoperative, follow the Troubleshooting Guidelines in TABLE 5-1; these represent the most likely causes of a problem. You may return inoperative instruments that are under warranty to MSA:
 - **MSA North America
Repair and Service Department
1000 Cranberry Woods Drive
Cranberry Township, PA 16066-5207
1-800-MSA-INST**
- To contact MSA International, please call:
 - **1-412-967-3000 or 1-800-MSA-7777**



⚠ WARNING

Repair or alteration of the ALTAIR Pro Single Gas Detector, beyond the procedures described in this manual or by anyone other than a person authorized by MSA, could cause the instrument to fail to perform properly. Use only genuine MSA replacement parts when performing any maintenance procedures described in this manual. Substitution of components can seriously impair instrument performance, alter intrinsic safety characteristics or void agency approvals.

FAILURE TO FOLLOW THIS WARNING CAN RESULT IN SERIOUS PERSONAL INJURY OR DEATH.

- The instrument displays an error code if it detects a problem during startup or operation. See TABLE 5-1 for a brief description of the error and proper corrective action.
- When an inoperative component is located by using the guidelines, consult the "Repair Procedures" later in this chapter to see if it is a replaceable part.

Table 5-1. Troubleshooting Guidelines

PROBLEM	DESCRIPTION	ACTION
DISPLAY TOGGLES BETWEEN:		
TMP/ERR	Temperature out of range	Return instrument to normal temperature range and recalibrate. If condition persists, contact MSA during warranty period.
AD/ERR	Sensor feedback error	Remove battery and recalibrate. If condition persists, contact MSA during warranty period.
EE/ERR	EEPROM inoperative	Contact MSA during warranty period
PRG/ERR	Program Memory inoperative	Contact MSA during warranty period
RAM/ERR	RAM inoperative	Contact MSA during warranty period
LED/ERR	LED inoperative	Verify operation of two alarm LEDs in alarm
VIB/ERR	Vibrator inoperative	Verify operation of vibrator in alarm
UNK/ERR	Unknown Error	Contact MSA during warranty period
UND/ERR	Sensor Under range	Calibrate instrument
	Low battery warning indicator and beep every 30 seconds	Remove from service as soon as possible and replace battery
 /ERR	Low battery Alarm indicator (horn sounds, LEDs activate)	Instrument is no longer sensing gas. Remove from service and replace battery
SNS/ERR	Sensor Error	Calibrate instrument. If instrument fails calibration, replace sensor
Instrument does not turn ON	Low battery	Replace battery
MEM/RST	EEPROM Data Error	Calibrate instrument. Reconfigure any custom settings (alarm setpoints, datalog, etc.)

Repair Procedures

CAUTION

Before handling the PC board, ensure you are properly grounded; otherwise, static charges from your body could damage the electronics. Such damage is not covered by the warranty. Grounding straps and kits are available from electronics suppliers.

Replacing the ALTAIR Pro Battery

1. Remove the four screws securing the case halves together after the instrument is turned OFF (except Steel Mill version).
2. Carefully remove the front cover to expose the battery.
 - The circuit board will remain with the back half of the case.
 - Do not touch the display connections (two blue connectors)
3. Remove the depleted battery and replace only with one specified in TABLE 6-2.
 - Be sure to observe proper polarity on the battery, as shown on the battery holder.
4. Replace the front cover, making sure the sensor, horn gasket and sensor gasket are properly seated. For the Remote O₂ instrument only, ensure that sensor pins located on the front case align with the circuit board sockets in the back case.
5. Ensure the interface and connectors for the display are clean and free of dirt for proper operation.
 - If needed, clean display connectors with a soft, lint free cloth.
6. Replace the four screws.

NOTES:

- Changing instrument battery can result in lost time in the Data log.
- After changing batteries, verify the Time and Date with your PC via the IR mode and the FiveStar Link. See Chapter 2 for more details on entering IR mode. Once the instrument is communicating via IR and the FiveStar link, the instrument time automatically synchronizes with the PC.
- The time and date is based on the PC time and date. Ensure the PC is correct before communicating with the instrument.

CAUTION

Do not over-tighten screws; otherwise, case may be damaged.

Replacing the ALTAIR Pro Sensor (Except Remote O₂ Version)

1. Remove the four screws securing the case halves together after the instrument is turned OFF (except Steel Mill version).
2. For Steel Mill version only, remove battery before proceeding with sensor replacement.
3. Carefully remove the front cover to expose the sensor (located near the top of the instrument, near the alarm lights).
4. Remove the sensor from its sockets.
5. Install the new sensor in the sockets on the PC board (it can only be installed one way). If replacement sensor is equipped with a "shorting" clip, it must be removed prior to installation in the instrument. Fully seat the sensor against the board.
6. Replace the front cover, making sure the sensor, horn gasket, and sensor gasket are properly seated.
7. Ensure the interface and connectors for the display are clean and free of dirt for proper operation.
 - If necessary, the display connectors can be cleaned with a soft, lint-free cloth.
8. Replace the four screws.

▲ CAUTION

Do not over-tighten the screws; otherwise, the case may be damaged.

9. The instrument **MUST** be calibrated as previously described. Allow a minimum of 60 minutes after the new sensor is installed before calibrating to ensure the new sensor reaches equilibrium.

▲ CAUTION

The new replacement sensor must be the same part number and type as the one being replaced; otherwise, improper operation will result.

▲ WARNING

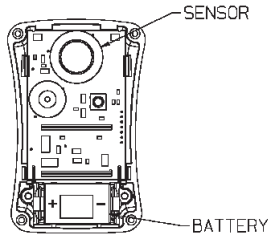

Calibration is required after a sensor is installed; otherwise, the instrument will not perform as expected and persons relying on this product for their safety could sustain serious personal injury or death.



**Figure 5-1. Sensor and Battery Replacement
(Except Remote O₂ Version)**

Chapter 6, Performance Specifications

Table 6-1. Certifications

HAZARDOUS LOCATIONS	US 	AEx ia IIC T4 Class I Groups A, B, C, and D; Class II, Group G T _{amb} -20°C to +50°C Temperature Code T4
	CANADA 	Ex ia IIC T4 Class I Groups A, B, C, and D; Class II, Group G T _{amb} -20 °C to +50°C Temperature Code T4
	AUSTRALIA	Ex ia IIC T4 (Tamb 50°C)
	EUROPE 	II 1G EEx ia IIC T4 Ga -20°C ≤ T _{amb} . ≤ +50°C
IEC		Ex ia IIC T4 -20°C ≤ Tamb. ≤ + 50°C
EMC/RFI	EUROPE 	89/336/EEC
ENCLOSURE		IP 67
APPLICABLE EUROPEAN DIRECTIVES	EUROPE	ATEX: 94/9/EC EMC: 89/336/EEC LVD: 73/23/EEC

Conditions for Safe Use

- Use a Lithium battery listed in Table 6-2 only.
- The equipment enclosure includes accessible metal parts. The end user shall determine suitability in the specific application. The measured capacitance of the equipment on the belt clip is 40pF.

Table 6-2. Instrument Specifications

OPERATING TEMPERATURE RANGE	-20 to 50°C (-4 to +122°F), [NH ₃ , ClO ₂ : -20 to 40°C (-4 to 104°F),							
HUMIDITY	10 to 95% RH, Non condensing							
INGRESS PROTECTION	IP67, (Remote O ₂ is IP54)							
RECOMMENDED STORAGE	0 to 40°C (32° to 104°F)							
WARRANTY	See Chapter 5							
AUDIBLE ALARM	95 dB typical							
APPROXIMATE SIZE	3.4" H x 2.0" W x 1" D (8.6 cm H x 5.1 cm W x 2.5 cm D)							
WEIGHT	4 oz (113 grams)							
SENSOR	Electrochemical Sensors							
BATTERY	Lithium, CR2, non-rechargeable: Replace with Energizer CR2 EL1CR2BP, Panasonic CR-2PA/1B, Varta CR2 6206, or Varta (Power One) CR2 CR15H270, 6206 battery only							
FACTORY-SET* ALARM SETPOINTS								
	LOW* ALARM (PPM)	HIGH* ALARM (PPM)	STEL* (PPM)	TWA* (PPM)	MIN. ALARM SET-POINT	MAX. ALARM SET-POINT	FAS TIME (SEC)	CAL/SPAN TIME (SEC)
O₂	19.5%	23.0%	--	--	5.0	24	<15	90
PH₃	0.3	1.0	1.0	0.3	0.1	3.75	<15	90
HCN	4.5	10.0	10.0	4.5	1.0	20.0	<15	240
ClO₂	0.10	0.30	0.30	0.10	0.10	0.75	<15	360
NOTE:								
This instrument has not been classified for use in atmospheres containing >21% oxygen.								
* Other setpoints available upon request or at any time via MSA FiveStar Link Software.								

Table 6-3. Oxygen Typical Performance Specifications

RANGE	0-25% O ₂ (Oxygen)
RESOLUTION	0.1% O ₂
REPRODUCIBILITY	0.7% O ₂ for 2-25% O ₂ *
RESPONSE TIME	90% of final reading 30 seconds (normal temperature range*). Three minutes (extended temperature range**)
* normal temperature range 0-40°C	
** extended temp. range -20 to 0, 40 to 50°C	

Table 6-4. Toxic Performance Specifications

SENSOR:	PH ₃ (Phosphine)
RANGE:	0-5.0 ppm
RESOLUTION:	0.05 ppm
SENSOR:	HCN (Hydrogen Cyanide)
RANGE:	0-30.0 ppm
RESOLUTION:	0.5 ppm
SENSOR:	ClO ₂ (Chlorine Dioxide)
RANGE:	0-1.00 ppm
RESOLUTION:	0.02 ppm
* Normal temperature range 0-40°C	
** extended temp. range -20 to 0, 40 to 50°C (NH ₃ and ClO ₂ only: -20 to 0°C)	

Table 6-5. Data Logging Specifications

SESSION DATALOG	NUMBER OF SHARED EVENTS	50 (most recent occurrences)	
	DATA TRANSMISSION METHOD	Via MSA infrared adapter on a PC using MSA FiveStar Link Software > version 4.5	
	EVENT LOG INFORMATION		Alarm - Alarm Type - Alarm Value - Time/Date
			Alarm Clear - Alarm Type - Alarm Value - Time/Date
			Cal (Pass/Fail) - Time/Date
			Bump (Pass/Fail) - Time/Date
			Error Non-Shutdown - Error Type (See Error List) - Time/Date
		ON/OFF - Time/Date.	
	TRANSMISSION TIME	Typically less than 60 seconds max.	
PERIODIC DATALOG	DEFAULT LOGGING INTERVAL	Three minute peak readings (configurable via PC from 15 seconds to 15 minute peaks or one minute peak average)	
	STORAGE ESTIMATE	Typically greater than 100 hours with default interval (storage time varies based on interval and sensor activity)	
	TRANSMISSION TIME	Typically less than three minutes	

Chapter 7, Replacement and Accessory Parts

Table 7-1. Replacement Parts List

PART/COMPONENT	PART NO.
Cylinder, 60 ppm CO (factory setting calibration gas)	710882
Cylinder, 300 ppm CO RP (factory setting calibration gas)	473180
Cylinder, 40 ppm H ₂ S, RP (factory setting calibration gas)	467897
Cylinder, 40 ppm H ₂ S, Econocal	711062
Cylinder, 10 ppm NO ₂ , Econocal	711068
Cylinder, 10 ppm NO ₂ , RP	808977
Cylinder, 10 ppm SO ₂ , Econocal	711070
Cylinder, 10 ppm SO ₂ , RP	808978
Cylinder, 25 ppm NH ₃ , Econocal	711078
Cylinder, 25 ppm NH ₃ , RP	814866
Cylinder, 10 ppm Cl ₂ , Econocal	711066
Cylinder, 10 ppm Cl ₂ , RP	806740
Cylinder, 2 ppm Cl ₂ , Econocal	711082
Cylinder, 2 ppm Cl ₂ , RP	10028080
Cylinder, 10 ppm HCN, Econocal	711072
Cylinder, 10 ppm HCN, RP	809351
Cylinder, 0.5 ppm PH ₃ , Econocal	711088
Cylinder, 0.5 ppm PH ₃ , RP	710533
Regulator, 0.25 lpm	467895
Regulator, 0.25 lpm, Combination	711175
Tubing, 40 cm (16") (not used for NH ₃ , Cl ₂ or ClO ₂)	10030325
Tubing, 40 cm (16"), Tygon (NH ₃ , Cl ₂ , ClO ₂ only)	10080534
Clip, Suspender Style, black	10040002
Clip, Suspender Style, Stainless Steel	10069894
Cell Phone Belt Clip	10041105
Lanyard Kit	10041107

FiveStar Link with IR (optional for event logging)	710946
Sensor Gasket	10071375
Horn Gasket	10067102
Battery - CR2	10074132
Screws, Case	636267
Clip, Hard Hat	10073346
Front Case Replacement Assembly with Gaskets (without front label)	10075629
Front Case Label, O ₂	10068694
Front Case Label, H ₂ S	10068696
Front Case Label, CO	10068695
Front Case Label, CO Steel	10074153
Front Case Label, CO Fire	10074154
Front Case Label, NO ₂	10068699
Front Case Label, SO ₂	10068702
Front Case Label, NH ₃	10068700
Front Case Label, Cl ₂	10068697
Front Case Label, ClO ₂	10068698
Front Case Label, HCN	10068701
Front Case Label, PH ₃	10068703
Front Case Label, O ₂ -Remote Version	10068693
Front Case Replacement Assembly with Gasket, O ₂ -Remote Version	10078275
Sensor, CO, Steel Mill, H ₂ Resistant	10080219
Sensor, CO (Carbon Monoxide)	711306
Sensor, H ₂ S (Hydrogen Sulfide)	711307
Sensor, O ₂ (Oxygen)	10046946
Sensor, HCN (Hydrogen Cyanide)	10080220
Sensor, Cl ₂ (Chlorine)	10080221
Sensor, SO ₂ (Sulfur Dioxide)	10080223
Sensor, NO ₂ (Nitrogen Dioxide)	10080224
Sensor, NH ₃ (Ammonia)	10080225
Sensor, PH ₃ (Phosphine)	10080226
Sensor, O ₂ -Remote Version	10016798
Sensor, ClO ₂ (Chlorine Dioxide)	10080222
Cable Assembly, 10-foot, O ₂ -Remote Version	10080493
O-Ring (for O ₂ -Remote Version Cable - two required)	635511