

Manual

con::cube D-330

July 2022 Release



Table of Contents

1	General	5
2	Safety Guidelines	6
2.1	Declaration of Conformity	6
2.2	Special Hazard Warning	6
3	Technical Description	7
3.1	Intended Use	7
3.2	Functional Principle	7
3.3	Product	8
3.4	Storage, Transport and Disposal	10
3.5	Scope of Delivery	11
3.6	Product Updates, Other	11
4	Installation	12
4.1	Environment	12
4.2	Mounting	13
5	Initial Startup	14
5.1	Plan of Terminal Connections	14
5.2	Connection of s::can Spectrometer Probe	15
5.3	Connection of s::can ISE Probes and Sensors	16
5.4	Connection of Cleaning Devices	16
5.5	Connection of Main Power Supply	17
5.6	Starting up of Operation Software	17
5.7	con::cube Sleep Mode	17
6	Operation of con::cube	18
6.1	Direct Operation of con::cube	18
6.2	Remote Operation of con::cube	18
6.2.1	Remote Operation of con::cube via Webbrowser	19
6.2.2	Remote Operation of con::cube via Terminal Program (VNC-Viewer)	19
6.3	con::cube Interfaces	20
6.4	con::cube Network Integration and Security	20
6.5	con::cube Connection Types	22
6.5.1	Connectivity via Network Cable (RJ45)	22
6.5.2	Connectivity via WLAN	23
6.5.3	Connectivity via 3G / 4G Modem	23
6.5.4	Connectivity via VPN	24
7	Data Management	25
7.1	Data Storage	25
7.2	Data Transfer	25
7.3	Data Types	25
7.4	Data Transfer via Modbus Interface	27
7.5	Data Transfer via Profibus DP Interface	31
7.6	Data Transfer via SDI12 Interface	32

8	Function Check	33
8.1	Check System / Monitoring Station	33
9	Maintenance	34
9.1	Cleaning	34
9.2	Desiccant Package	34
9.3	Housing	34
9.4	Calibration Touch Screen	35
10	Troubleshooting	36
10.1	Device Settings	36
10.2	Software Update	36
10.3	Return Consignment (RMA - Return Material Authorization)	36
11	Accessories	37
11.1	Installation	37
11.1.1	Weather Shield	37
11.1.2	Power Supply Cord	37
11.1.3	External Antenna and Connector	38
11.2	Automatic Cleaning	40
11.2.1	Cleaning Valve	40
11.3	Spare Parts	41
11.3.1	Desiccant Package	41
11.3.2	Touch Pen	41
11.4	Optional Features	42
11.4.1	Gateway to 3G / 4G Modem	43
11.4.2	Analog Output Module	44
11.4.3	Digital Output Module	44
11.4.4	Profibus DP Output Module	44
11.4.5	SDI 12 Output Module	45
11.4.6	Analog Input Module	45
11.4.7	Digital Input Module	45
11.4.8	Connector Plug for external Antenna	46
12	Technical Specifications	47
12.1	Terminal- and Address Assignment for optional I /O Modules	49
12.2	Pin Assignment for optional Profibus DP connector (Sub-D9)	49

1 General

This manual contains, firstly, general information (chapter 1) and safety guidelines (chapter 2). The next chapter (chapter 3) provides a technical description of the s::can product itself as well as information regarding transport and storage of the product. In further chapters the installation (chapter 4) and the initial startup (chapter 5) are explained. Furthermore information regarding calibration of the device (chapter 6), data management (chapter 7), how to perform a function check (chapter 8) and maintenance (chapter 9) can be found in this manual. Information regarding troubleshooting (chapter 10), the available accessories (chapter 11) and the technical specifications (chapter 12) complete the document.

Each term in this document that is marked *italic and underlined*, can be found on the display of your controller for operation or as lettering on your s::can product.

In spite of careful elaboration this manual may contain errors or incompleteness. s::can does not assume liability for errors or loss of data due to such faults in the manual. The original manual is published in English and German by s::can. This original manual serves as the reference in case discrepancies occur in versions of the manual after translation into third languages.

This manual and all information and figures contained therein are copyrighted. All rights (publishing, reproduction, printing, translation, storage) are reserved by s::can GmbH. Each reproduction or utilisation outside the permitted limits of the copyright law is not allowed without previous written consent from s::can GmbH. The reproduction of product names, registered trade names, designation of goods etc. in this manual does not imply that these names can be used freely by everyone; often these are registered trade marks, even if they are not marked as such.

This manual, at the time of its publication (see release date printed on the top of this document), concerns the s::can products listed in chapter 3. Information and technical specifications regarding these items in s::can manuals from earlier release dates are herewith replaced by this manual.

The electronic version (pdf-document) of this manual is available on the s::can Customer Portal (Services for Customer) of the s::can website (www.s-can.at).

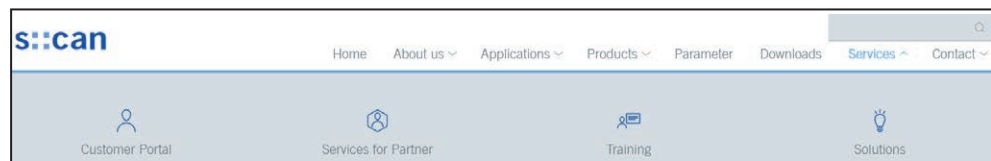



2 Safety Guidelines

Installation, electrical connection, initial startup, operation and maintenance of any s::can product as well as complete s::can measuring systems must only be performed by qualified personnel. This qualified personnel has to be trained and authorised by the plant operator or by s::can for these activities. The qualified personnel must have read and understood this manual and have to follow the instructions contained in this manual.



For proper initial startup of complete s::can measuring systems, the manuals for the controller and software used for operation (e.g. con::lyte, con::cube, con::nect, moni::tool), the connected probes and sensors as well as the used additional devices (e.g. compressor) have to be consulted.

 The operator has to obtain the local operating permits and has to comply with the joint constraints associated with these. Additionally, the local legal requirements have to be observed (e.g. regarding safety of personnel and means of labour, disposal of products and materials, cleaning, environmental constraints). Before putting the measuring device into operation, the operator has to ensure that during mounting and initial startup - in case they are executed by the operator himself - the local legislation and requirements (e.g. regarding electrical connection) are observed.

 All s::can products are leaving our factory in immaculate technical and safety conditions. Inappropriate or not intended use of the product, however, can cause danger! The manufacturer is not responsible for damage caused by incorrect or unauthorised use. Any kind of manipulation of the instrument is strictly prohibited - except for the activities described in this document. Conversions and changes to the device must not be made, otherwise all certifications and guarantee / warranty become invalid. For details regarding guarantee and warranty please refer to our general conditions of business.

2.1 Declaration of Conformity

This s::can product has been developed, tested and manufactured for electromagnetic compatibility (EMC) and according to applicable European standards, as defined in the declaration of conformity.

CE-marks are applied on the device. The declaration of conformity related to this marking can be requested from s::can or your local s::can sales partner or can be downloaded from the s::can Customer Portal.

2.2 Special Hazard Warning

 Because the s::can measuring systems are frequently installed in industrial and communal waste water applications, one has to take care during mounting and demounting of the system, as parts of the device can be contaminated with dangerous chemicals or pathogenic germs. All necessary precautions should be taken to prevent endangering of one's health during work with the measuring device.

3 Technical Description

3.1 Intended Use

The con::cube is an high-performance, power efficient industrial computer for on-line operation of s::can spectrometer probes (spectro::lyser, nitro::lyser, carbo::lyser, etc.) and i::scan as well as ISE probes (e.g. ammo::lyser) and all other s::can sensors (e.g. pH::lyser, oxi::lyser). Furthermore readings of third party sensors can be integrated via standard interfaces. Once connected to probes and sensors the con::cube fullfils all tasks of a complete monitoring station due to the following scope of functions:

- Numerical and graphical display of the readings from the connected measuring devices
- Simple initialisation of spectrometer probes, i::scan, ISE probes and sensors
- Simple initialisation and parameterisation of s::can infrastructure (e.g. automatic cleaning devices)
- Parameter calibration of spectrometer probes, i::scan, ISE probes and sensors
- Storage of measurement results and all other station information in a local database

- Transfer of measurement results via Modbus RTU/TCP interface
- Transfer of measurement results via analog outputs (optional)
- Transfer of measurement results via Profibus DP interface (optional)
- Transfer of measurement results via SDI12 interface (optional)
- Transfer of measurement results via FTP / sFTP file transfer
- Potential free digital output relay triggered by current reading (optional)

- Integration of external sensor signals via RS485 input
- Integreation of external sensor signals via analog or digital input (optional)

- Network connectivity via ethernet, WLAN or optional 3G / 4G modem
- Remote control of s::can monitoring station via ethernet, WLAN or optional 3G / 4G modem
- Data synchronisation to central data collection systems via ethernet, WLAN or optional 3G / 4G modem
- Display of current and historical readings
- Alarming and Triggering depending on water quality monitored

In all types of applications, the respective acceptable limits, which are provided in the technical specifications in the respective s::can manuals, have to be observed. All applications falling outside of these limits, and which are not authorised by s::can GmbH in written form, do not fall under the manufacturer's liability.

The device must only be used for the purpose described in this manual. Use in applications not described in this manual, or modification of the device without written agreement from s::can, is not allowed. s::can is not liable for claims following from such unauthorised use. In such a case, the risks are the sole responsibility of the operator.

3.2 Functional Principle

The con::cube is equipped with an operation software (moni::tool) that can be operated via a color graphical display with touch functionality. The software starts automatically when the con::cube is powered up. The con::cube collects readings for probes and sensors using a digital bus connection. It displays the data, stores all information and makes it available for further use.





3.3 Product

The following device variants of the con::cube are available. Regarding detailed information of the device variants, please refer to the technical specifications located at the end of this manual.

Type	Specification
D-330-230	Operator terminal with 100-240 VAC, 50-60 Hz power supply
D-330-024	Operator terminal with 10-36 VDC power supply
D-330-TOUCH	Display and touch screen input module
D-315-3GLX	3G modem (OS Linux)
D-330-4GLX	4G modem (OS Linux)
D-315-OUT-PROFIBUS	Profibus DP (output module)
D-315-OUT-SDI12	SDI 12 (output module)
D-315-OUT-MA	2 analog outputs (output module)
D-315-OUT-RELAY	4 digital outputs (output module)
D-315-IN-MA	2 analog inputs for integration of third party readings (input module)
D-315-IN-RELAY	2 digital inputs for integration of third party readings (input module)
D-315-ANTENNA-PLUG	internal antenna adapter cable and connector for 3G modem
D-330-ANTENNA-PLUG	internal antenna adapter cable and connector for 3G or 4G modem
D-315-ANTENNA-PRO	external, high range antenna, incl. 10 m extension cable for 3G modem
D-330-ANTENNA-PRO	external, high range antenna, incl. 10 m extension cable for 3G or 4G modem
D-303-LX	Licence Linux application (fix installed OS)
S-20-MVA	Complete license including moni::tool (all features), vali::tool and ana::tool

The device is typified by a type label, as shown on the right, that contains the following information:

- Manufacturer’s name and country of origin
- Several certification marks
- Device name (con::cube)
- Type of power supply
- Bar code
- Device serial number (S/N)
- Information on power supply
- Environment rating (IP)
- Acceptable humidity limits
- Acceptable temperature limits
- Item number (Type)
- QR code

s::can    



s::can GmbH
Brigittagasse 22-24,A-1200
MADE IN AUSTRIA

con::cube V3 100 - 240 VAC ~
230 V 50/60Hz, 60W
IP65, 5 - 90% RH
non condensing, -20 - 50 °C
Type: D-330-230



S/N: 20193600



s::can MADE IN AUSTRIA   

s::can GmbH
Brigittagasse 22-24,A-1200

con::cube V3 10 - 36 VDC
24 V 50W
IP65, 5 - 90% RH
non condensing, -20 - 50 °C
Type: D-330-024



S/N: 19123700



- 1** Color graphical display with touch screen
- 2** Screw to open housing cover
- 3** Control LED (blue, yellow or red)
- 4** 1 connector for s::can spectrometer probe
- 5** 4 connectors for i::scan, ISE probes or sensors
- 6** Ethernet (LAN) connector
- 7** USB connector
- 8** 2 cable glands M16 (optional for Profibus or antenna plug)
- 9** 3 cable glands M16
- 10** 1 cable gland M16 (optional antenna plug)
- 11** 2 cable glands M20
- 12** Holder for housing cover
- 13** Desiccant package
- 14** Insert for SIM card
- 15** Additional cable terminals for connection to 12 VDC out
- 16** Grounding bar
- 17** Power supply connection

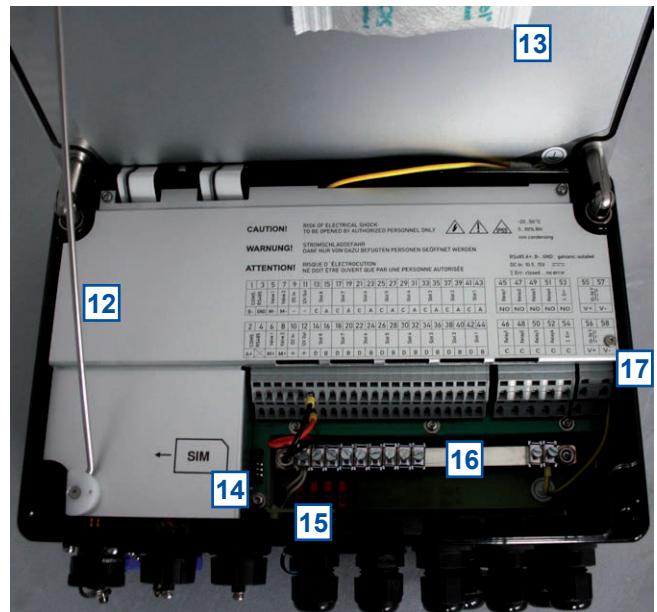

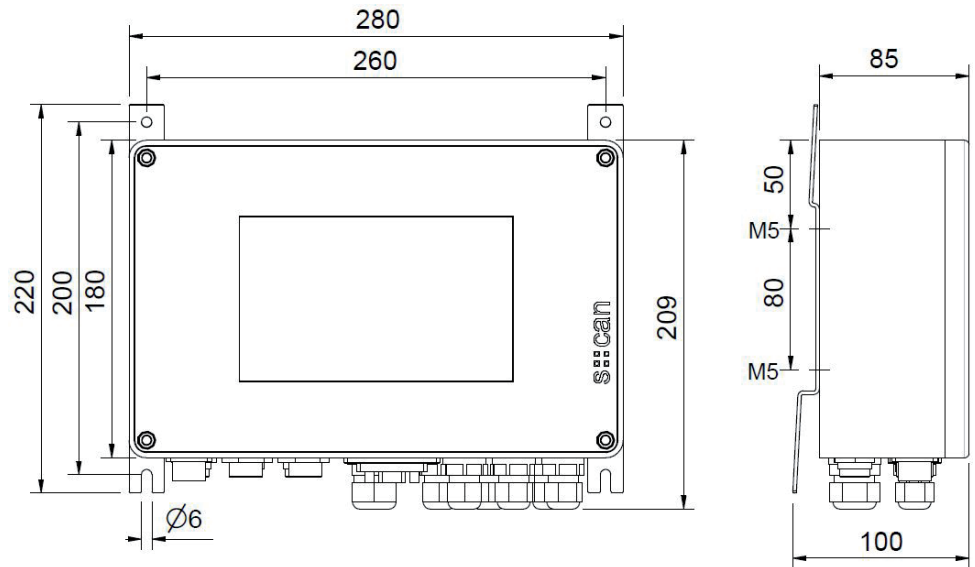

Ensure correct orientation of mounting rails. Top of con::cube has to be tilted backwards to prevent any water flowing over the touch screen or entering the housing when device is opened.

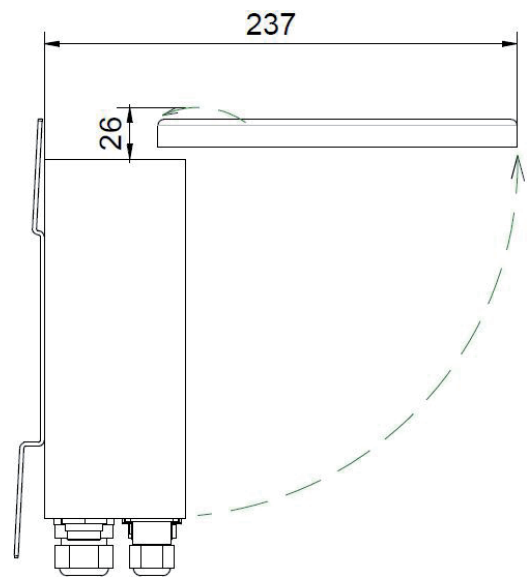

Dimensions of con::cube in mm

3.4 Storage, Transport and Disposal

The limiting values for device storage and transport, which are described in the section technical specifications, have to be observed at all times. The device shall not be exposed to strong impacts, mechanical loads or vibrations. The device should be kept free of corrosive or organic solvent vapours, nuclear radiation as well as electromagnetic radiation.

Damage to the device caused by wrong storage will not be covered by warranty.

Transport should be done in a packaging that protects the device (original packaging or protective covering if possible).



This product is marked with the WEEE symbol to comply with the European Union's Waste Electrical & Electronic Equipment (WEEE) Directive 2012/19/EC. The symbol indicates that this product should not be treated as household waste. It must be disposed and recycled as electronic waste. Please assist to keep our environment clean.



Take care that no sharp-edged or heavy objects are placed on the housing cover, which might scratch and / or damage the touch screen.

3.5 Scope of Delivery

Immediately upon receipt, please check the received consignment for completeness on the basis of the delivery note and check for any possible damage incurred during shipping. Please inform the delivering dispatcher and s::can immediately in case of any damages in transit.

The following parts should be included in the delivery:

- s::can con::cube (part-no. D-330-xxx)
- Pen for touch screen
- Mounting rail (2 pieces) with 4 screws (M5x8)
- s::can manual con::cube (part-no. S-453-M)

The following parts could be included in the delivery if ordered as an option:

- Cable for power supply (part-no. C-31-xx)
- Gateway to 3G / 4G (part-no. D-315-3GLX / part-no. D-330-4GLX)
- Internal antenna cable and connector (part-no. D-315-ANTENNA-PLUG / D-330-ANTENNA-PLUG)
- External antenna (part-no. D-315-ANTENNA-PRO / D-330-ANTENNA-PRO)
- Different I/O modules, which are assembled into the con::cube already (part-no. D-315-OUT-MA, D-315-OUT-RELAY, D-315-PROFIBUS, D-315-OUT-SDI12, D-315-IN-MA, D-315-IN-RELAY)
- s::can weather shield for con::cube (part-no. F-51)

In case of incompleteness please contact your s::can sales partner immediately!

3.6 Product Updates, Other

The manufacturer reserves the rights to implement, without prior notice, technical developments and modifications in the light of continuous product care.

4 Installation

4.1 Environment



The con::cube is designed according to environmental protection rating IP 65 and is resistant against environment effects. Indoor use is preferred. In case of outdoor use the installation in a cabinet or on the separately available weather shield is highly recommended to protect the device (housing cover has to be securely closed).

Enclosure class IP 65 protection is only guaranteed if the housing cover is fixed tightly with the four screws, an operative desiccant package is mounted inside the housing and the sealing of the housing cover is undamaged and placed correctly. In addition all cable glands have to be sealed correctly in that way they are closed tightly with the appropriate cables or dummy caps. All connectors must be covered with corresponding caps when not in use. Any damage caused by intrusion of water will not be covered by the warranty.

The correct installation of measuring instruments is an important prerequisite for satisfactory operation. Therefore the following checklist for the installation can be used to ensure that all sources for potential operational problems can be ruled out to the greatest possible extent during the installation, allowing the s::can monitoring system to operate properly.

Installation site:

- Easy accessibility (mounting, sampling, function check, demounting)
- Availability of sufficient space (probe / sensor, installation fitting, controller for operation, etc.)
- Adherence to limit values (see technical specifications located at the end of this manual)
- Best possible weather and splash water proof set-up

Infrastructure (energy, data and compressed air):

- Power supply for controller for operation (operational reliability, voltage, power, peak free)
- Oil- and particle free compressed-air supply (optional for automatic probe / sensor cleaning)
- Shortest possible distances between system components (probe – controller – compressed-air supply – energy supply)
- Correct dimensioning, mounting and protection of all cables and lines (non-buckling, no risk of stumbling, no damage etc.)

4.2 Mounting

For mounting and electrical installation the following tools and materials are necessary:

- Hexagonal wrench key (size 5) to open housing cover
- Torx wrench key (size TX 25) for fixing screws of mounting rails
- 2 s::can mounting rails (included in delivery)
- 4 screws (M5) and 4 washers for fixing the two mounting rails onto the con::cube (included in delivery)
- 4 screws for fastening the con::cube on the wall (if required)
- Weather shield (F-51, if required)
- Power supply cable (C-31-xx, if required)
- Stripping tool for power supply line
- Cable end sleeves and crimper

The con::cube can be mounted quickly and easily onto a flat wall using one of the following methods:

- With the two mounting rails [1] included in delivery. Fasten the two mounting rails onto the backside of the con::cube using the four screws [2] and the four spring washers [3] as shown on the right.
- With the four threaded holes on the backside of the con::cube to mount the device directly from the backside (M5 screws, not included in delivery).

For the correct dimensioning and space required for mounting please refer to the figures in section 3.3 and the technical specifications.

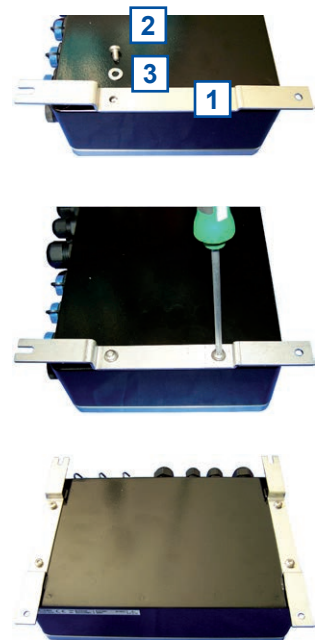

5 Initial Startup

Once mounting and installation of the con::cube have been completed and checked (see section 4) the initial startup of the s::can monitoring system will require the following actions, in the order presented below:

- Connect the s::can spectrometer probes (see section 5.2).
- Connect the s::can ISE probes, i::scan and sensors (see section 5.3).
- Connect the cleaning devices to the proper terminal connections in the cable terminal compartment (see section 5.4).
- Connect of optional devices used for the s::can nano::station or micro::station, e.g. flow detector F-45-ALARM or pressure sensor F-500-P.
- Establish main power supply to the con::cube (see section 5.5) and wait until the operation software moni::tool has started up (see section 5.6).
- Please note all information in the moni::tool manual for further startup and configuration of the monitoring system.

5.1 Plan of Terminal Connections

Once the housing cover has been opened (four hexagonal head screws removed) you have access to the cable terminal compartment of the con::cube (see section 11.4 also).

 Opening of the cable terminal compartment must be carried out by authorised persons only (see section 2) and after disconnecting the power supply!

 Be aware that cable clamps of relay contacts you have connected to the device might also have power supply (230 VAC), depending on how they have been interconnected!

The con::cube is equipped with spring terminals that enable quick and easy wiring.

- Insert a small screwdriver into the slot above the cable clamp you want to connect (see left picture below).
- Move the screwdriver upwards, which opens the cable clamp, and insert the wire (see middle picture below).
- Move the screwdriver downwards and remove it. Now wire is locked in the cable clamp (see right picture below).

 s::can recommends to use wires with isolated end sleeves for power supply and data transfer.



CAUTION!

RISK OF ELECTRICAL SHOCK
TO BE OPENED BY AUTHORIZED PERSONNEL ONLY



-20...50°C
5...90% RH
non condensing

WARNUNG!

STROMSCHLAGGEFAHR
DARF NUR VON DAZU BEFUGTEN PERSONEN GEÖFFNET WERDEN

ATTENTION!

RISQUE D'ÉLECTROCUTION
NE DOIT ÊTRE OUVERT QUE PAR UNE PERSONNE AUTORISÉE

RS485 A+, B-, GND: galvanic isolated
Σ Err: closed ... no error

1	3	5	7	9	11	13	15	17	19	21	23	25	27	29	31	33	35	37	39	41	43	
COM5, RS485	Valve1	Valve2	WkUp	12V Out	Slot 8	Slot 7	Slot 6	Slot 5	Slot 4	Slot 3	Slot 2	Slot 1										
B - GND	M -	M -	-	-	C	A	C	A	C	A	C	A	C	A	C	A	C	A	C	A	C	A

45	47	49	51	53	55	57
Relay1	Relay2	Relay3	Relay4	Σ Err	110-240 V	
NO	NO	NO	NO	NO	P	N

2	4	6	8	10	12	14	16	18	20	22	24	26	28	30	32	34	36	38	40	42	44	
COM5, RS485	Valve1	Valve2	WkUp	12V Out	Slot 8	Slot 7	Slot 6	Slot 5	Slot 4	Slot 3	Slot 2	Slot 1										
A+ X	M+	M+	+	+	D	B	D	B	D	B	D	B	D	B	D	B	D	B	D	B	D	B

46	48	50	52	54	56	58
Relay1	Relay2	Relay3	Relay4	Σ Err	110-240 V	
C	C	C	C	C	P	N

Plan of terminal connections for con::cube D-330-230

CAUTION!

RISK OF ELECTRICAL SHOCK
TO BE OPENED BY AUTHORIZED PERSONNEL ONLY



-20...50°C
5...90% RH
non condensing

WARNUNG!

STROMSCHLAGGEFAHR
DARF NUR VON DAZU BEFUGTEN PERSONEN GEÖFFNET WERDEN

ATTENTION!

RISQUE D'ÉLECTROCUTION
NE DOIT ÊTRE OUVERT QUE PAR UNE PERSONNE AUTORISÉE

RS485 A+, B-, GND: galvanic isolated
Σ Err: closed ... no error

1	3	5	7	9	11	13	15	17	19	21	23	25	27	29	31	33	35	37	39	41	43	
COM5, RS485	Valve1	Valve2	WkUp	12V Out	Slot 8	Slot 7	Slot 6	Slot 5	Slot 4	Slot 3	Slot 2	Slot 1										
B - GND	M -	M -	-	-	C	A	C	A	C	A	C	A	C	A	C	A	C	A	C	A	C	A

45	47	49	51	53	55	57
Relay1	Relay2	Relay3	Relay4	Σ Err	10-36 V	
NO	NO	NO	NO	NO	V+	V-

2	4	6	8	10	12	14	16	18	20	22	24	26	28	30	32	34	36	38	40	42	44	
COM5, RS485	Valve1	Valve2	WkUp	12V Out	Slot 8	Slot 7	Slot 6	Slot 5	Slot 4	Slot 3	Slot 2	Slot 1										
A+ X	M+	M+	+	+	D	B	D	B	D	B	D	B	D	B	D	B	D	B	D	B	D	B

46	48	50	52	54	56	58
Relay1	Relay2	Relay3	Relay4	Σ Err	10-36 V	
C	C	C	C	C	V+	V-

Plan of terminal connections for con::cube D-330-024

5.2 Connection of s::can Spectrometer Probe

An s::can spectrometer probe can be connected to the external connector for spectrometer probes, which is marked with no.4 in the figure of section 3.3. If an extension cable is used the total length of the probe's cable should not be more than 40 m.

If necessary, a con::nect box (B-23-xxx or B-33-012) has to be used to connect a further spectrometer probe.

5.3 Connection of s::can ISE Probes and Sensors

Alternative or additional to the spectrometer probe it is possible to connect ISE probes, i::scan and / or s::can sensors via the sys plug connectors located on the con::cube. These connectors are marked with no.5 in the figure of section 3.3. If an extension cable is used the total length of the probe's cable should not be more than 40 m.

If necessary, the distribution box (B-41-HUB) has to be used to increase the number of plugs.



Before connecting the probes or sensors, ensure that the sensor plug and connector on the con::cube are dry and clean. Otherwise communication errors and / or device damage might occur. Connectors not in use should always be covered with the protective cap.

5.4 Connection of Cleaning Devices

For the automatic cleaning of the probe and sensors connected, the cleaning devices have to be wired to the con::cube within the cable terminal compartment. The table below displays the different possibilities of connection.

Cleaning Device	Colour of wire	Labelling	Terminal no.
Cleaning valve via Valve 1	Blue	M+ / Valve 1	6
	Brown	M- / Valve 1	5
Cleaning valve via Valve 2	Blue	M+ / Valve 2	8
	Brown	M- / Valve 2	7
Autobrush via Valve 1	Purple (yellow ¹⁾)	M+ / Valve 1	6
	Black (brown ¹⁾)	- / 12V Out	11 / black terminal
	Red (white ¹⁾)	+ / 12V Out	12 / red terminal
Autobrush via Valve 2	Purple (yellow ¹⁾)	M+ / Valve 2	8
	Black (brown ¹⁾)	- / 12V Out	11 / black terminal
	Red (white ¹⁾)	+ / 12V Out	12 / red terminal
ruck::sack via Valve 1	Purple (yellow ¹⁾)	M+ / Valve 1	6
	Black (brown ¹⁾)	- / 12V Out	11 / black terminal
	Red (white ¹⁾)	+ / 12V Out	12 / red terminal
ruck::sack via Valve 2	Purple (yellow ¹⁾)	M+ / Valve 2	8
	Black (brown ¹⁾)	- / 12V Out	11 / black terminal
	Red (white ¹⁾)	+ / 12V Out	12 / red terminal

¹⁾ previous / alternatively used cable version

Once the cleaning device has been electrically connected, the device needs to be parameterised within the moni::tool software (please refer to manual moni::tool).

5.5 Connection of Main Power Supply

 This type of work must be performed by authorised persons only (see section 2)!

Depending on the device type, the con::cube has to be connected to the appropriate power supply. The connection of power supply (AC or DC, respectively), must be done with an earthed conductor wire (PE - „protective earth“)!

The power supply earth (PE) has to be done properly according to the corresponding norms / standards with a max. resistance between earth grounding of power supply and site's earth grounding of 0.1 Ohm.

Process medium (e.g. waste water) must be connected to the same earth ground with less than 0.5 Ohm.

Connection of power supply for con::cube D-330-230	
No / [Labelling]	Assignment
55 / [P] or 56 / [P]	Conductor or phase, resp.
57 / [N] or 58 / [N]	Neutral wire

Connection of power supply for con::cube D-330-024	
No / [Labelling]	Assignment
55 / [V+] or 56 / [V+]	+ 24 VDC
57 / [V-] or 58 / [V-]	- 24 VDC

The connection in the cable terminal compartment has to be performed as displayed on the table above. The ground wire (PE) has to be connected to the grounding bar of the con::cube, which is marked with no.16 in the figure of section 3.3.

 A switch or circuit-breaker must be included in the power supply. It must be suitable located and easily reachable. It must be marked as a disconnecting device for the monitoring equipment.

5.6 Starting up of Operation Software

Once the con::cube is connected to the power supply (see section 5.5), it will show the s::can logo for a few seconds while starting up. During the startup of moni::tool a message as shown on the right hand side is visible. Please consider that the complete start up procedure will require approx. 1 - 2 minutes.

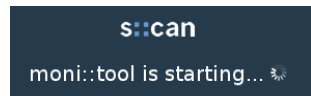

When no probes and sensors have been installed yet (initial startup), only the main window and the menu tabs are visible on the display.

Please refer to the manual of the operation software moni::tool for all further tasks to complete the initialisation of your s::can monitoring system.

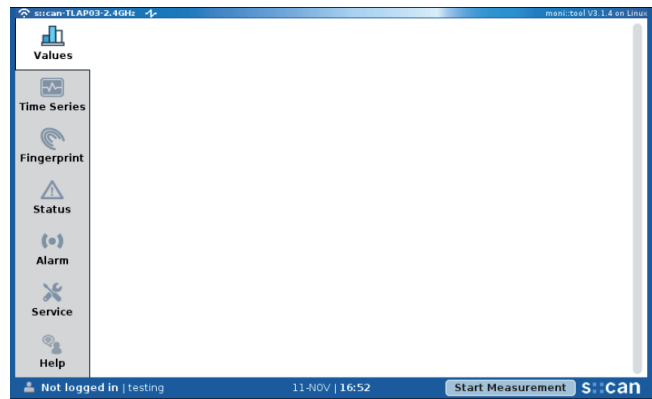

5.7 con::cube Sleep Mode

For operation with low power consumption a specific sleep mode can be configured on the con::cube via moni::tool (Service \ Terminal \ con::cube \ Power Save). The sleep mode can be terminated at any time by touching the screen or by apply a voltage of 12 VDC to the WkUp terminals (9 and 10).

 When using the sleep mode in combination with a 3G / 4G modem, the most actual moni::tool version V3.1.4 has to be used. When using an older version, a modification of a jumper is needed (information note how to do this is available via s::can customer support).

6 Operation of con::cube

The con::cube is equipped with the operating software moni::tool and uses multi touch technology and a webbrowser as graphical user interface. This means that moni::tool can be operated via webbrowser either directly on the touch screen of the con::cube with your fingers and / or a touch pen (see section 6.1) or via remote connection using a PC, notebook, tablett, etc. (see section 6.2). Please note that only one user can operate the con::cube directly (i.e. can be logged on).

The main frame of the moni::tool display contains the following items that are visible at all times.

- 1 Tabs for navigating between the main views
- 2 Clicking on this item will open the login window or logout window
- 3 Name of the monitoring station
- 4 Current system date and time (clicking on this icon will display date / time of the last measurement)
- 5 Clicking on the s::can logo will callup information on the installed software version and the controller
- 6 Scrollbar to scroll the display up and down

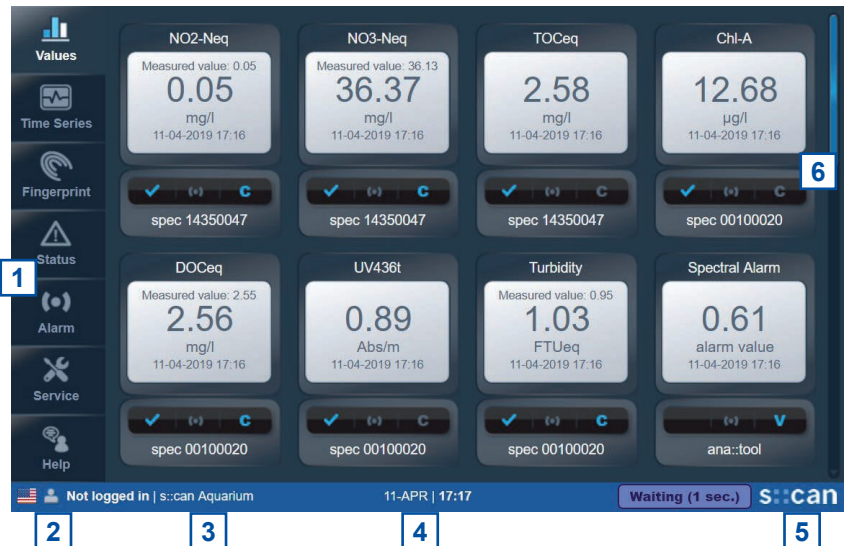

6.1 Direct Operation of con::cube

Normally this direct operation is performed by a person standing in front of the con::cube and using the touch screen. Alternatively moni::tool can also be operated with a USB mouse and / or a USB keyboard. These devices can be connected to the USB-socket (marked with no.7 in the figure of section 3.3) of the con::cube. A USB-hub can be used to operate keyboard and mouse simultaneously.

Please keep in mind that a few service actions (e.g. touch calibration) can be used in direct operation only (see manual moni::tool).

6.2 Remote Operation of con::cube

For any kind of remote operation the con::cube needs to be connected to the internet, a VPN network, a local network or directly to a PC (see section 6.5).

6.2.1 Remote Operation of con::cube via Webbrowser

The moni::tool software can be operated from any computer that has access to the con::cube. Simply enter the IP address of the con::cube into the address bar of your Webbrowser.

Several users can view moni::tool simultaneously but only one user can be logged in.

User = Administrator
Password = admin1

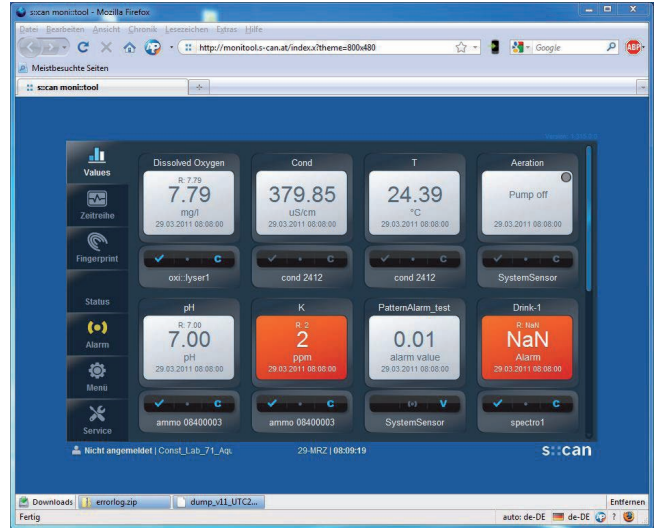
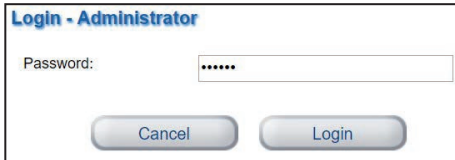

6.2.2 Remote Operation of con::cube via Terminal Program (VNC-Viewer)

The terminal program VNC-Viewer can be used for direct operation of the con::cube via remote connection. In this case keyboard, mouse and monitor of the computer running the VNC-Viewer can be used to operate the con::cube.

If you operate the con::cube via VNC-Viewer, all actions can be seen on the touch screen of the con::cube also.

When using the VNC-Viewer a login window will pop up once the remote connection was successful.

! For operation of VNC-Viewer with moni::tool Version V3 the port 5900 has to be unlocked in the con::cube firewall. The VNC password to be entered is „scan“ (case-sensitive).

! For operation of VNC-Viewer with moni::tool Version V4 the VNC authentication has to be enabled on the con::cube (Service / Terminal / Security / VNC Authentication) and an individual VNC password can be entered (see figure on the right).

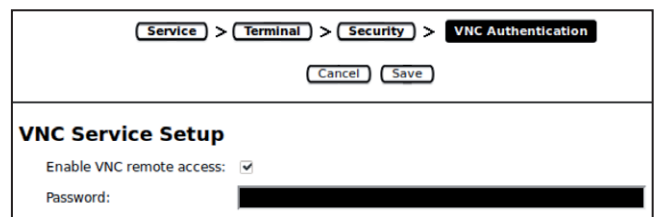
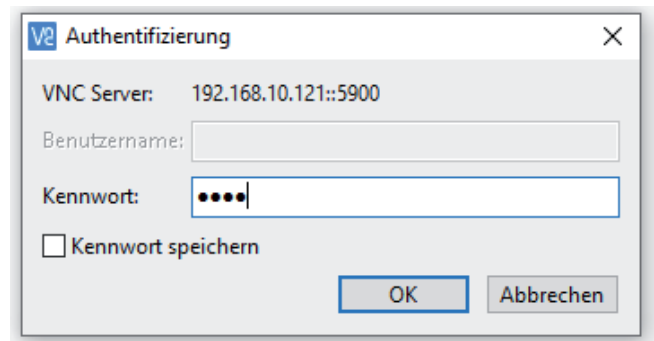

6.3 con::cube Interfaces

The figure below offers an overview of all available interfaces, that can be used for operation of the con::cube.

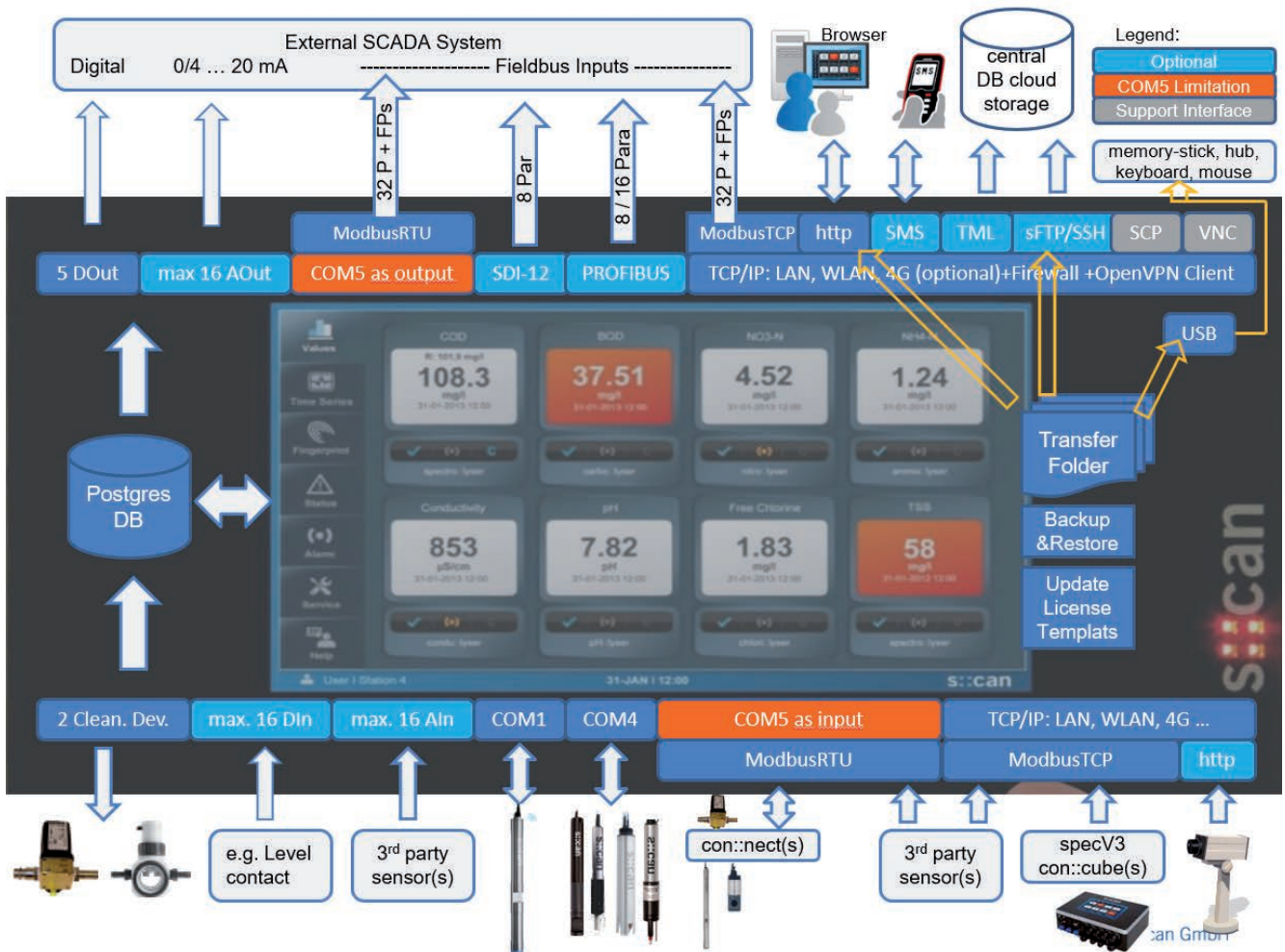

6.4 con::cube Network Integration and Security

For normal operation, remote control, data transfer and other features it might be necessary to setup a connectivity of the con::cube. Within this section the different possibilities are explained and security background is mentioned also.

The con::cube is based on Microsoft Windows XP embedded (XPe) operating system until moni::tool versions V2.5. From Version 3.0 on it is based on a Linux operating system (Debian).



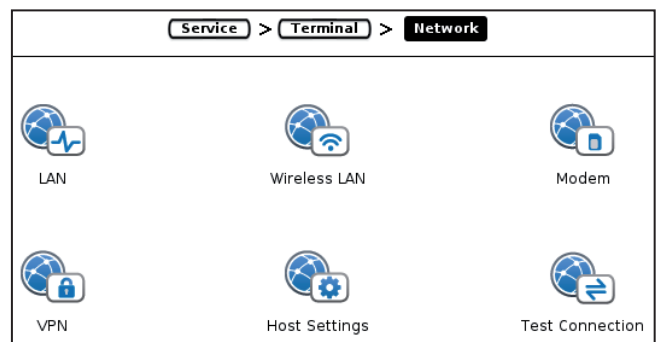



While the XPe platform is well-proven and stable it already has reached the end of its mainstream support. Microsoft will still supply security updates within a certain period but won't fix non-critical issues. Linux will support further security updates.





Nonetheless, the con::cube is a complex device offering services over the network. Software security therefore is an issue which needs to be considered to safely operate the con::cube.

On the con::cube the TCP / IP interface can be used via LAN, WLAN or 3G / 4G Modem (optional). All these features can be configured within the Service / Terminal / Network menu (see manual moni::tool).

The table below contains all types of possible connectivity setups. Regarding the individual connection types please refer to the subsections afterwards.

con::cube	Type of data transfer	Connection type	Customer infrastructure	Security
acts as client (i.e. con::cube establishes the connection, performs a task and shuts down the connection)	<ul style="list-style-type: none"> ■ FTP / sFTP data transfer ■ SSH data transfer ■ NTP-client (for system time synchronization) 	all connection types	FTP / sFTP server SSH server	
acts as server (i.e. con::cube waits for a client to connect and responds to its request)	<ul style="list-style-type: none"> ■ Modbus TCP ■ TML ■ VNC remote control ■ FTP remote control 	LAN or WLAN	trusted network	
		3G/4G private IP	internet	
		3G/4G private IP	VPN server	
		3G/4G public IP		
		open WLAN without WEP		

 Because of the number of services offered, the con::cube MUST NOT be operated in environments where those services can be reached public. i.e. the con::cube MUST NOT be reachable from the internet. The most common configurations that are NOT safe are a 3G / 4G connection with a public IP address and a WLAN connection to a public, non-encrypted network.

 It is always safe to operate the con::cube in a private network, i.e. in a LAN unless the firewall is configured to forward external requests to the con::cube (port-forwarding).

6.5 con::cube Connection Types

If one or several con::cube shall be integrated into one network, each device needs it's own IP address and also it's own computer name. By default the DHCP service is activated on the con::cube, therefore an IP address for the con::cube will be allocated automatically from the DHCP server of the network to which the con::cube is connected. The actual IP address of the con::cube will be displayed when pushing on the s::can logo on the lower right hand side of the moni::tool display.

If needed the DHCP service can be deactivated and the con::cube can be set to a fixed IP address. This might be necessary if a direct connection from the con::cube to your notebook shall be established. In this case perform the following steps:

- Disable the Use DHCP checkbox on con::cube to deactivate the DHCP Server option (Service / Terminal / Network Settings / LAN Adapter).
- Ensure your PC is equipped with a properly installed network card and you have the user rights required to change network settings.
- Configure the IP address of your PC in the Network environment also to a fixed one, using the same settings as for the con::cube except the last number of the IP address. The example below shows a possible configuration:
 IP address of the con::cube: 192.168.10.12
 IP address of the PC: 192.168.10.2
 Subnet mask for both devices: 255.255.255.0
- Connect your network cable (RJ45) to the con::cube and to the PC when working via LAN (see section 6.5.1).
- Alternatively activate the WLAN on your notebook and on the con::cube (see section 6.5.2).
- Search for the con::cube in the Network environment of the PC. You can either use the IP address or the computer name of the con::cube for searching. The computer name ex factory can be found on the included acceptance certificate.
- In case a logon is needed use:
 User: scan
 Password: scan (case sensitive)

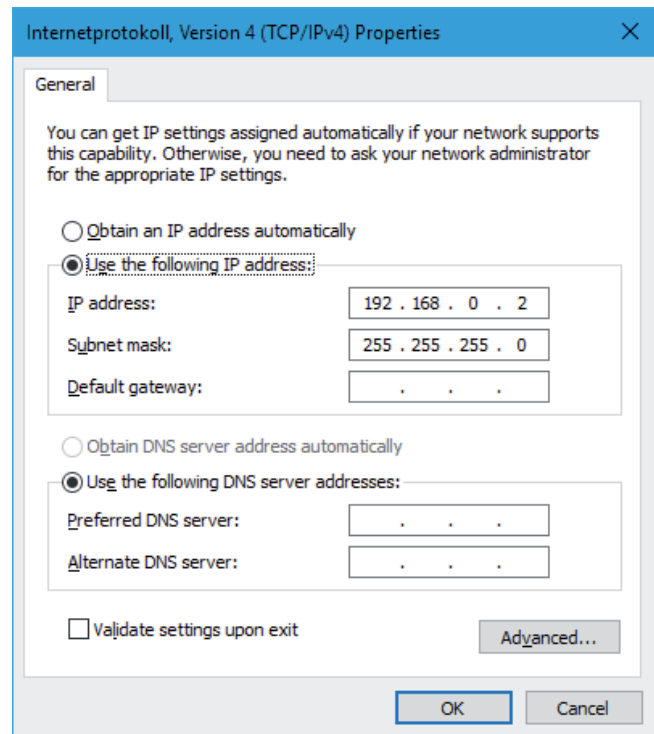

6.5.1 Connectivity via Network Cable (RJ45)

Connect the con::cube into the local area network (LAN) by plugging a network cable of the LAN into the ethernet socket of the con::cube (RJ45 - marked with no.6 in the figure in section 3.3).

If needed, it can be configured via the moni::tool menu item Service / Terminal / Network Settings / LAN Adapter.

To ensure proper operation also with older types of PC / notebook, s::can recommends to use a cross-linked RJ45 cable for connection.

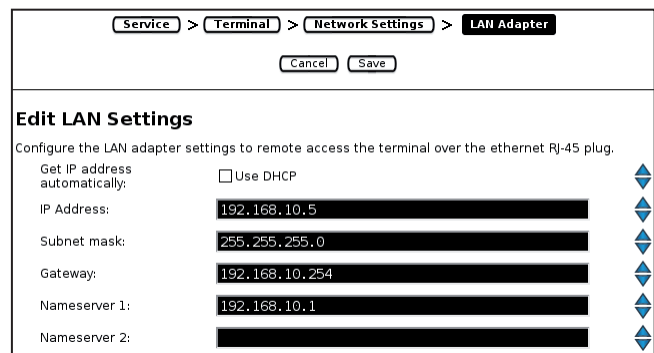

6.5.2 Connectivity via WLAN

The con::cube is equipped with an internal WLAN modem. The antenna is included in the housing cover. When you enable the WLAN modem via the `moni::tool` menu *Service / Terminal / Network Settings / WLAN* all available connections are displayed.

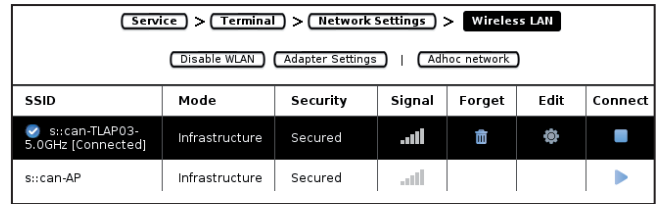

6.5.3 Connectivity via 3G / 4G Modem

Optionally the con::cube can be equipped with an internal 3G / 4G modem. The antenna for this modem is already integrated in the housing cover. In addition an external antenna can be mounted (see section 11.1.3). As long as no SIM card is installed the modem status is *No SIM inserted*.

The configuration of the internal modem is performed by the following steps:

- Power off the con::cube, open the housing cover and install a SIM card into the holding signed with no.14 in the figure of section 3.3 . This SIM should be suited for data transfer and needs to support GPRS / 3G / 4G.
- Power on the con::cube. The modem status will be *Ok (SIM Status)* and *SMS only (Status)*.
- Configure a new modem profile (e.g. by editing the existing *Default* profile) via *Service / Terminal / Network Settings / Modem*.
- Select *Default* and push icon *Edit*.
- Enter a *Profile* name and the *PIN* of the SIM card.
- Enter the *Apn* and the *Authentication* of your provider.
- To avoid any problems select *Allow roaming* always.
- Push the *save* button to save your modem profile.
- Now the con::cube tries to connect to the network.
- After successful connection a user message asks you to reboot the con::cube. Push the button *Remind me later* to finish your modem configuration.
- Push the *Connect* symbol (blue triangle) to activate your modem profile.
- Once the con::cube is connected successfully the connection symbol is displayed in the left top corner. In addition you see the signal strength and the name of your provider.
- Reboot your con::cube to make all changes permanent.

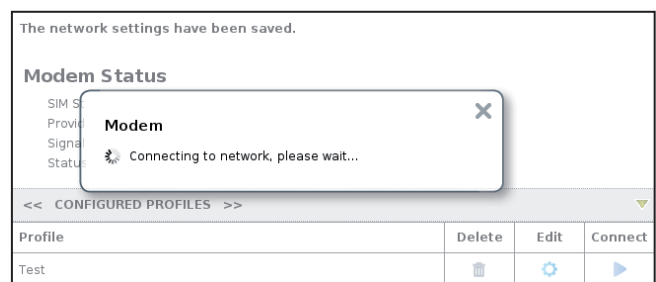
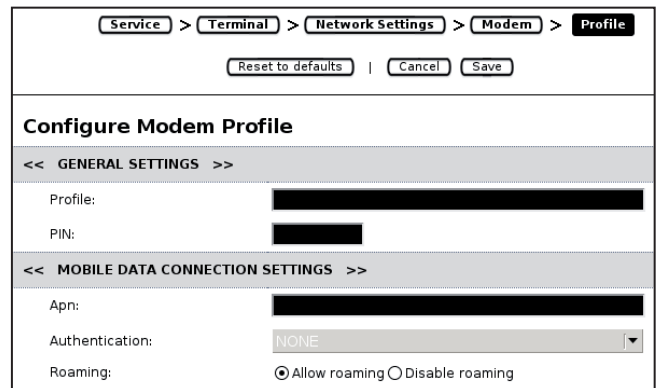
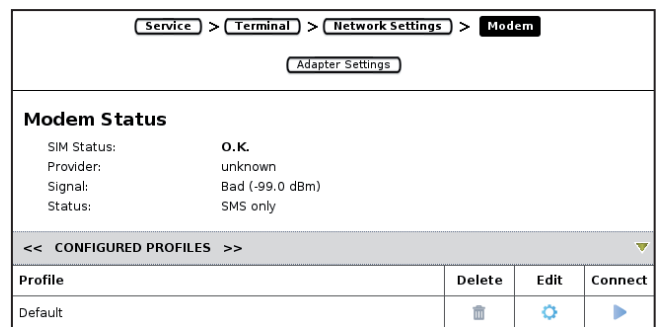

6.5.4 Connectivity via VPN

The con::cube can be connected to a VPN server. s::can offers the possibility to connect your con::cube to the s::can VPN server (item-no. S-VPN-HOSTING). Please ask your local s::can Sales Partner for further details.

The configuration of a VPN profile on the con::cube is performed by the following steps:

- Select menu *Service / Terminal / Network Settings / VPN* to open the configuration screen.
- In case any VPN profile exists already, select this profile and delete it by pushing the trash icon.
- Push the button *Add new Profile*.
- Within the next window select the *VPN Type*, which is always *OpenVPN Custom*.
- Push the button *Save*.
- Within the next window enter a *Profile name*.
- Select the file containing the *Private key password* (e.g. *password.txt*).
- Select the file containing the *OpenVPN configuration* (e.g. *client.ovpn*).
- Push the button *Save*.
- Now the new profile should be listed in the table. Push the button *Enable* to activate the profile.
- Once the con::cube is connected to the VPN the display will look like the figure on the right.
- The static IP address of the VPN connection will be displayed after pushing the s::can logo in the lower right corner.

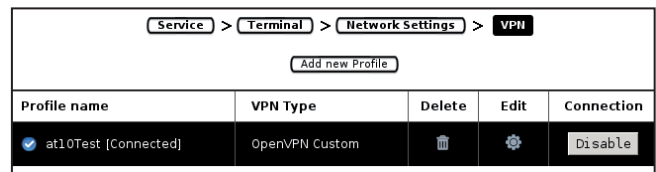
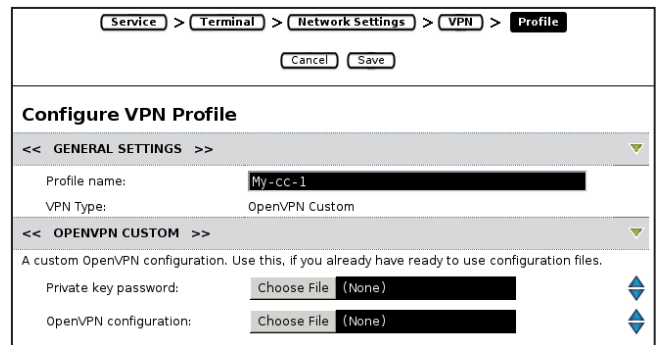
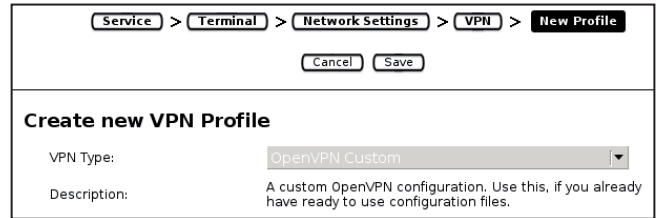

A specific note can be downloaded from the s::can Customer Portal, explaining how a VPN connection can be setup on a mobile phone or tablett.

7 Data Management

7.1 Data Storage

The moni::tool software uses an SQL database for storage of all measurement results, configuration data and information. The size of the database depends on the storage capacity of the flash disk in the con::cube (see technical specifications).

Performing a database dump provides the possibility to save or archive all data stored in the database. Please refer to manual moni::tool for further details.

7.2 Data Transfer

The con::cube with moni::tool provides several possibilities to transfer measurement results and other data and information to external devices.

Transfer of measurement results:

- via analog power outputs (optional D-315-OUT-MA)
- via digital relay interfaces (optional D-315-OUT-RELAY)
- via Modbus TCP/IP interface (Ethernet RJ45, see figure on the right and manual moni::tool)
- via Modbus RTU interface (COM-5, see figure on the right and manual moni::tool). When using Modbus RTU, the COM-5 port cannot be used as sensor interface.
- via Profibus DP interface (optional D-315-OUT-PROFIBUS, see figure on the right and moni::tool manual)
- via SDI12 interface (optional D-315-OUT-SDI12, see figure on the right and moni::tool manual)
- via TML stream (see manual moni::tool menu item Service / Outputs / TML)

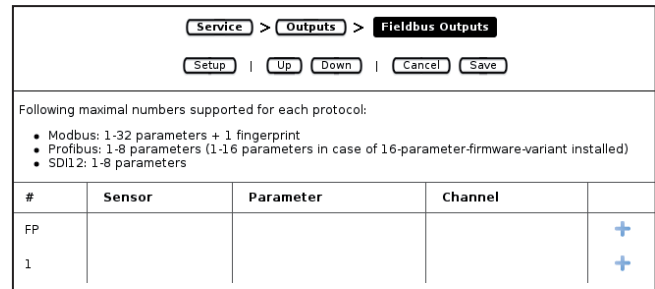

Transfer of measurement result files:

- automatical via FTP / sFTP (see manual moni::tool Service / Outputs / File Output / FTP Transfer)
- automatical via SSH (see manual moni::tool Service / Outputs / File Output / SSH Transfer)
- manual to a USB-stick or a connected computer

For more detailed information about data transfer (e.g. configuration) please refer to the moni::tool manual.

7.3 Data Types

All s::can interfaces use a common representation of data types. Each accessible data item can be allocated to one of the types shown in the table below. The type of a given item can always be found by checking the Modbus mapping. In addition the name of the data item are prefixed by one or two letters to indicate the data type. Data types which are non standard need special attention and are marked specially. Data from Modbus mapping are directly mapped to the according Profibus address space.

Type	Description	Size (Bytes)	Prefix	Note
char[x]	string	x	ab	ASCII
bitmask	bitmask of 16 bits	2	bm	
int16	signed 16 bit integer	2	i	NaN = INT 16_MAX
unit16	unsigned 16 bit integer	2	ui	NaN = UNIT 16_MAX
float	IEEE-754 floating pints	4	f	NaN = 0xFFFF FFFF NaN = 0x7FC0 0000
enum	enum type	2	e	
timestamp TAI64N	timestamp format	6	ts	see http://cr.yip.to/proto/tai64.txt

 For all data types the Big-Endian encoding is used.

- Characters are represented in ASCII. A single character (for example „a“) with ASCII code 0x61 has the following mapping:

	Modbus register															
Register address	b15	b14	b13	b12	b11	b10	b9	b8	b7	b6	b5	b4	b3	b2	b1	b0
0xXXXX	0x61='a'								0x00							

- Character strings are represented in ASCII and have a fixed size. If not all bytes are needed the string must be filled with trailing spaces. A three character string (for example “abc”) of size 4 has the following mapping:

	Modbus register															
Register address	b15	b14	b13	b12	b11	b10	b9	b8	b7	b6	b5	b4	b3	b2	b1	b0
0xXXXX	0x61='a'								0x62='b'							
0xXXXX + 1	0x63='c'								0x20=' '							

- The bitmask is used to represent up to 16 logical states. Unused states are zero by convention. A logical state with bits a15 to a0 has the following mapping:

	Modbus register															
Register address	b15	b14	b13	b12	b11	b10	b9	b8	b7	b6	b5	b4	b3	b2	b1	b0
0xXXXX	a15	a14	a13	a12	a11	a10	a9	a8	a7	a6	a5	a4	a3	a2	a1	a0

For example bitmask with a15:0 = (1100 1010 0011 0110) has the mapping

	Modbus register															
Register address	b15	b14	b13	b12	b11	b10	b9	b8	b7	b6	b5	b4	b3	b2	b1	b0
0xXXXX	1	1	0	0	1	0	1	0	0	0	1	1	0	1	1	0

- An signed 16bit integer = ±0xXXYY (int16) has the following mapping:

	Modbus register															
Register address	b15	b14	b13	b12	b11	b10	b9	b8	b7	b6	b5	b4	b3	b2	b1	b0
0xXXXX	0xXX								0xYY							

For example -17289 = 0xBC77 has the mapping

	Modbus register															
Register address	b15	b14	b13	b12	b11	b10	b9	b8	b7	b6	b5	b4	b3	b2	b1	b0
0xXXXX	0xBC								0x77							

- An unsigned 16bit integer = 0xXXYY (unit16) has the following mapping:

	Modbus register															
Register address	b15	b14	b13	b12	b11	b10	b9	b8	b7	b6	b5	b4	b3	b2	b1	b0
0xXXXX	0xXX								0xYY							

For example 45311 = 0xB0FF has the mapping

	Modbus register															
Register address	b15	b14	b13	b12	b11	b10	b9	b8	b7	b6	b5	b4	b3	b2	b1	b0
0xXXXX	0xB0								0xFF							

- Floats are represented in IEEE-754 format with 32bit standard precision and have the following mapping:

	Modbus register															
Register address	b15	b14	b13	b12	b11	b10	b9	b8	b7	b6	b5	b4	b3	b2	b1	b0
0xXXXX	s	e7	e6	e5	e4	e3	e2	e1	e0	f22	f21	f20	f19	f18	f17	f16
0xXXXX + 1	f15	f14	f13	f12	f11	f10	f9	f8	f7	f6	f5	f4	f3	f2	f1	f0

- Timestamps are presented in TAI64n format, which is an unsigned integer counting the seconds from 1.1.1970 using the big-endian format. 1.1.1970 = 0x4000 0000 0000 0000 + 0x0000 0000, e.g. 400000004d9b3395 = 2011-04-05 15:21:47 (for further details please refer to www.tai64.com).

7.4 Data Transfer via Modbus Interface

The con::cube is equipped with a Modbus interface which support the standardized Modbus protocol via RTU or TCP / IP. This interface enables the integration of the con::cube into other networks and supports the following features:

- Reading of device description (see table - Mapping of Device specific Input Register or Device specific Holding Register)
- Reading of parameter results (see table - Mapping of Parameter specific Input Register or Parameter specific Holding Register)
- Reading of parameter status information (see table - Mapping of Parameter Status)
- Reading of system status information (see table - Mapping of System Status)

Access to this information is possible by reading input registers and / or by reading holding registers. The type and the location of the registers is described in the following sections.

The con::cube Modbus is specified according the Modbus-IDA Application Protocol V1.1a and supports the following function codes:

Function	Function code	Description (used for)
Read Input Register	0x04	Parameter readings Parameter status Device status
Read Holding Register	0x03	Device and parameter configuration settings, Mirrored input registers (for support of limited Modbus master devices)

Mapping of Device specific Input Register							
Input register, 16bit, RO	Tag name	Address	Type	Length	R/W	Description	Address
device description	uiVersion	0x0000	unit16	1	R	Version of Modbus mapping protocol. For all changes in public registers: 0xAABB AA ... Major version BB ... Minor version (compatible)	0
	eVendor	0x0001	enum	1	R	Vendor code	1
	eModel	0x0002	enum	1	R	Device model	2
	abModel	0x0003	char[20]	10	R	Description of device model, filled with spaces	3
	abSerialNumber	0x000D	char[8]	4	R	Serial number, filled with spaces	13
	abSWRelease	0x0013	char[4]	2	R	Software release: 0xAABB AA ... Major version BB ... Minor version	19
device status public	tSampleTime	0x0068	time-stamp	6	R	Time when the parameter results have been updated. Timestamp of logged status and results	104
	bmDeviceStatus	0x0078	bitmask	1	R	Device status	120

Mapping of Parameter specific Input Register							
Input register, 16bit, RO	Tag name	Address	Type	Length	R/W	Description	Address
parameter 1 result	bmP1Status	0x0080	bitmask	1	R	Para.1 status ¹⁾	128
	xP1Value	0x0082	float	2	R	Para.1 result	130
parameter 2 result	bmP2Status	0x0088	bitmask	1	R	Para.2 status ¹⁾	136
	xP2Value	0x008A	float	2	R	Para.2 result	138
parameter 3 result	bmP3Status	0x0090	bitmask	1	R	Para.3 status ¹⁾	144
	xP3Value	0x0092	float	2	R	Para.3 result	146
parameter 4 result	bmP4Status	0x0098	bitmask	1	R	Para.4 status ¹⁾	152
	xP4Value	0x009A	float	2	R	Para.4 result	154
parameter 5 result	bmP5Status	0x00A0	bitmask	1	R	Para.5 status ¹⁾	160
	xP5Value	0x00A2	float	2	R	Para.5 result	162
parameter 6 result	bmP6Status	0x00A8	bitmask	1	R	Para.6 status ¹⁾	168
	xP6Value	0x00AA	float	2	R	Para.6 result	170
parameter 7 result	bmP7Status	0x00B0	bitmask	1	R	Para.7 status ¹⁾	176
	xP7Value	0x00B2	float	2	R	Para.7 result	178
parameter 8 result	bmP8Status	0x00B8	bitmask	1	R	Para.8 status ¹⁾	184
	xP8Value	0x00BA	float	2	R	Para.8 result	186
parameter 9 result	bmP9Status	0x00C0	bitmask	1	R	Para.9 status ¹⁾	192
	xP9Value	0x00C2	float	2	R	Para.9 result	194

¹⁾ Please refer to table Mapping of Parameter Status

Mapping of Parameter specific Input Register							
Input register, 16bit, RO	Tag name	Address	Type	Length	R/W	Description	Address
parameter 10 result	bmP10Status	0x00C8	bitmask	1	R	Para.10 status ¹⁾	200
	xP10Value	0x00CA	float	2	R	Para.10 result	202
parameter 11 result	bmP11Status	0x00D0	bitmask	1	R	Para.11 status ¹⁾	208
	xP11Value	0x00D2	float	2	R	Para.11 result	210
parameter 12 result	bmP12Status	0x00D8	bitmask	1	R	Para.12 status ¹⁾	216
	xP12Value	0x00DA	float	2	R	Para.12 result	218
parameter 13 result	bmP13Status	0x00E0	bitmask	1	R	Para.13 status ¹⁾	224
	xP13Value	0x00E2	float	2	R	Para.13 result	226
parameter 14 result	bmP14Status	0x00E8	bitmask	1	R	Para.14 status ¹⁾	232
	xP14Value	0x00EA	float	2	R	Para.14 result	234
parameter 15 result	bmP15Status	0x00F0	bitmask	1	R	Para.15 status ¹⁾	240
	xP15Value	0x00F2	float	2	R	Para.15 result	242
parameter 16 result	bmP16Status	0x00F8	bitmask	1	R	Para.16 status ¹⁾	248
	xP16Value	0x00FA	float	2	R	Para.16 result	250
parameter 17 result	bmP17Status	0x0100	bitmask	1	R	Para.17 status ¹⁾	256
	xP17Value	0x0102	float	2	R	Para.17 result	258
parameter 18 result	bmP18Status	0x0108	bitmask	1	R	Para.18 status ¹⁾	264
	xP18Value	0x010A	float	2	R	Para.18 result	266
parameter 19 result	bmP19Status	0x0110	bitmask	1	R	Para.19 status ¹⁾	272
	xP19Value	0x0112	float	2	R	Para.19 result	274
parameter 20 result	bmP20Status	0x0118	bitmask	1	R	Para.20 status ¹⁾	280
	xP20Value	0x011A	float	2	R	Para.20 result	282
parameter 21 result	bmP21Status	0x0120	bitmask	1	R	Para.21 status ¹⁾	288
	xP21Value	0x0122	float	2	R	Para.21 result	290
parameter 22 result	bmP22Status	0x0128	bitmask	1	R	Para.22 status ¹⁾	296
	xP22Value	0x012A	float	2	R	Para.22 result	298
parameter 23 result	bmP23Status	0x0130	bitmask	1	R	Para.23 status ¹⁾	304
	xP23Value	0x0132	float	2	R	Para.23 result	306
parameter 24 result	bmP24Status	0x0138	bitmask	1	R	Para.24 status ¹⁾	312
	xP24Value	0x013A	float	2	R	Para.24 result	314
parameter 25 result	bmP25Status	0x0140	bitmask	1	R	Para.25 status ¹⁾	320
	xP25Value	0x0142	float	2	R	Para.25 result	322
parameter 26 result	bmP26Status	0x0148	bitmask	1	R	Para.26 status ¹⁾	328
	xP26Value	0x014A	float	2	R	Para.26 result	330
parameter 27 result	bmP27Status	0x0150	bitmask	1	R	Para.27 status ¹⁾	336
	xP27Value	0x0152	float	2	R	Para.27 result	338
parameter 28 result	bmP28Status	0x0158	bitmask	1	R	Para.28 status ¹⁾	344
	xP28Value	0x015A	float	2	R	Para.28 result	346
parameter 29 result	bmP29Status	0x0160	bitmask	1	R	Para.29 status ¹⁾	352
	xP29Value	0x0162	float	2	R	Para.29 result	354
parameter 30 result	bmP30Status	0x0168	bitmask	1	R	Para.30 status ¹⁾	360
	xP30Value	0x016A	float	2	R	Para.30 result	362

¹⁾ Please refer to table Mapping of Parameter Status

Mapping of Parameter specific Input Register							
Input register, 16bit, RO	Tag name	Address	Type	Length	R/W	Description	Address
parameter 31 result	bmP31Status	0x0170	bitmask	1	R	Para.31 status ¹⁾	368
	xP31Value	0x0172	float	2	R	Para.31 result	370
parameter 32 result	bmP32Status	0x0178	bitmask	1	R	Para.32 status ¹⁾	376
	xP32Value	0x017A	float	2	R	Para.32 result	378

¹⁾ Please refer to table Mapping of Parameter Status

Mapping of Device specific Holding Register							
Holding register, 16bit, RO	Tag name	Address	Type	Length	R/W	Description	Address
device description	uiVersion	0x0FA0	unit16	1	R	Version of Modbus mapping protocol. For all changes in public registers: 0xAABB AA ... Major version BB ... Minor version (compatible)	4000
	eVendor	0x0FA1	enum	1	R	Vendor code	4001
	eModel	0x0FA2	enum	1	R	Device model	4002
	abModel	0x0FA3	char[20]	10	R	Description of device model, filled with spaces	4003
	abSerialNumber	0x0FAD	char[8]	4	R	Serial number, filled with spaces	4013
	abSWRelease	0x0FB3	char[4]	2	R	Software release: 0xAABB AA ... Major version BB ... Minor version	4019
device status public	tSampleTime	0x0068	timestamp	6	R	Time when the parameter results have been updated. Timestamp of logged status and results	4104
	bmDeviceStatus	0x0078	bitmask	1	R	Device status	4120

Mapping of Parameter specific Holding Register							
Holding register, 16bit, RW	Tag name	Address	Type	Length	R/W	Description	Address
parameter 1 result	bmP1Status	0x1020	bitmask	1	R	Para.1 status ¹⁾	4128
	xP1Value	0x1022	float	2	R	Para.1 result	4130
parameter 2 result	bmP2Status	0x1028	bitmask	1	R	Para.2 status ¹⁾	4136
	xP2Value	0x102A	float	2	R	Para.2 result	4138
parameter 3 result	bmP3Status	0x1030	bitmask	1	R	Para.3 status ¹⁾	4144
	xP3Value	0x1032	float	2	R	Para.3 result	4146
.....							
parameter 32 result	bmP32Status	0x1118	bitmask	1	R	Para.32 status ¹⁾	4376
	xP32Value	0x111A	float	2	R	Para.32 result	4378

The representation of the system / device / parameter status and denotation of the single bits ($b_0 \dots b_{15}$) is shown in the tables below. Bits that are not represented in the tables are not supported or reserved.

Each bit represents a condition (1=error, 0=o.k.)

Mapping of Parameter Status (bmPxStatus)			
Bit	Display (xPxValue)	Status	Description
b0	NaN or value	General parameter error	<ul style="list-style-type: none"> ■ At least one internal parameter check failed ■ For details check all other status bits ■ Unknown failure if all other status bits are ok
b11	value	Maintenance necessary	<ul style="list-style-type: none"> ■ vali::tool recommends check of system integrity (function check) ■ If system integrity is ok, vali::tool configuration needs to be adapted.
b13	value	Parameter alarm	<ul style="list-style-type: none"> ■ ana::tool / alarm parameter reports parameter-alarm
b14	value	Parameter warning	<ul style="list-style-type: none"> ■ ana::tool / alarm parameter reports parameter-warning

Mapping of System Status (bmDeviceStatus)			
Bit	Display (xPxValue)	Status	Description
b0	NaN	General device error	<ul style="list-style-type: none"> ■ Communication to connected devices failed ■ Probe or sensor misuse ■ Probe or sensor malfunction or failure

7.5 Data Transfer via Profibus DP Interface

The Profibus DP output module (D-315-OUT-PROFIBUS) provides a Profibus DP compatible fieldbus interface (according to IEC 61158) for the integration of the con::cube into Profibus DP networks. Profibus DP supports up to 244 Bytes of output data. This enables the transfer of readings and status information for up to eight parameters as well as the system status. The location and type of the values are shown in the table below.

Profibus Position	Data Type	Name	Description
0x02 – 0x03	Bitmask	bmDeviceStatus	System status of con::cube
0x04 – 0x05	Bitmask	bmP1Status	Status of parameter 1
0x06 – 0x09	Float	xP1Value	Reading of parameter 1
0x0A – 0x0B	Bitmask	bmP2Status	Status of parameter 2
0x0C – 0x0F	Float	xP2Value	Reading of parameter 2
0x10 – 0x11	Bitmask	bmP3Status	Status of parameter 3
0x12 – 0x15	Float	xP3Value	Reading of parameter 3

Profibus Position	Data Type	Name	Description
0x16 – 0x17	Bitmask	bmP4Status	Status of parameter 4
0x18 – 0x1B	Float	xP4Value	Reading of parameter 4
0x1C – 0x1D	Bitmask	bmP5Status	Status of parameter 5
0x1E – 0x21	Float	xP5Value	Reading of parameter 5
0x22 – 0x23	Bitmask	bmP6Status	Status of parameter 6
0x24 – 0x27	Float	xP6Value	Reading of parameter 6
0x28 – 0x29	Bitmask	bmP7Status	Status of parameter 7
0x2A – 0x2D	Float	xP7Value	Reading of parameter 7
0x2E – 0x2F	Bitmask	bmP8Status	Status of parameter 8
0x30 – 0x33	Float	xP8Value	Reading of parameter 8
0x34 – 0x40	TAI64n	tSampleTime	Time of last measurement

7.6 Data Transfer via SDI12 Interface

The SDI12 module (D-315-OUT-SDI12) provides a SDI12 compatible fieldbus interface for the integration of the con::cube into SDI12 networks. The module enables the transfer of readings and status information for up to eight parameters as well as the system status. The location and type of the values are shown in the table in section 7.5.

Parameter readings can be queried via a SDI12-Master connected to the con::cube using a simple terminal program (e.g. Docklight). For reading of measurement results the following commands are needed (ASCII-code):

Action	Command	Description
Send	0M!<CR><LF>	Start measurement parameter 1
Answer	00001<CR><LF>	
Send	0D!<CR><LF>	Query of measurement result
Answer		Measurement result of parameter 1
Send	0M1!<CR><LF>	Start measurement parameter 2
Answer	00001<CR><LF>	
Send	0D!<CR><LF>	Query of measurement result
Answer		Measurement result of parameter 2
...		
Send	0M7!<CR><LF>	Start measurement parameter 8
Answer	00001<CR><LF>	
Send	0D!<CR><LF>	Query of measurement result
Answer		Measurement result of parameter 8

<CR> Carriage Return

<LF> Line feed

8 Function Check

A function check might be required for one of the following reasons:

- Initial startup
- Routine function check
- Suspicion of monitoring system malfunction
- Modification of monitoring system (e.g. integration of additional sensor or device)
- Change of measuring location

Depending on the application (water composition), the probes and sensors connected and the environmental conditions a regular function check (weekly to monthly) is recommended. The following sections provide an overview of all the actions that have to be performed to check the monitoring system quickly (see section 8.1). To check the plausibility of the displayed and collected readings and the integrity of a single probe or sensor, please refer to the according manuals of the connected probes and sensors.

8.1 Check System / Monitoring Station

What to check	How to check	What to do, if check failed
Power supply	LED on housing cover is on or at least flashing? moni::tool screen is displayed after touching the screen?	Check power supply. Dis- and reconnect power supply after one minute.
System running (up-to-date)	Click on system clock at the bottom of the moni::tool screen and check if current time and time of last measurement is current.	Check time and measurement settings. Please remind that polling of readings needs several seconds.
Automatic measurement active	Readings are actualized? Service mode not active?	Check measuring settings Leave Service mode
System status	LED is blue? Status icon is not flashing? Alarm icon is not flashing?	Click on flashing icon and see displayed information. See moni::tool manual for further details.
System stability	Check <u>Status > Terminal > Logbook</u> entries since last function check.	See help text and moni::tool manual for further details.
Installation	Housing, touch screen, cable connections and plugs are undamaged and tight?	Repair or replace damaged parts, that might influence the IP 65 protection (see section 4.1)
Function of automatic cleaning	Wait for next cleaning cycle or activate cleaning manually. Watch for air bubbles or listen if brush is rotating.	Check configuration, electrical connection, air tubes and cleaning device itself.
Efficiency of automatic cleaning	Perform function check of the probes and sensors connected to the automatic cleaning.	Improve automatic cleaning settings Replace cleaning brush
Datatransfer	Compare the readings displayed on the s::can terminal for operation with those readings received by the used SCADA system.	Check data transfer settings. Use test function to check data transfer.

9 Maintenance

9.1 Cleaning

The device housing is made of aluminium alloy. Only use a wet cloth tissue and drinking water and / or mild detergents (e.g. dish washing soap) for cleaning.

9.2 Desiccant Package

To avoid malfunctions due to condensing humidity, one desiccant package [1] is fixed on the cover of the con::cube (see picture on the right hand side). When the package has reached the maximum humidity absorption capacity (the blue-coloured label will turn pink in that case), it has to be exchanged. Before closing the con::cube, every time check the desiccant package.

 The desiccant package is not intended for the continuous absorption of humidity but only for the reduction of humidity below the dew point in a completely closed case. For this reason, properly closed housing cover and tightly screwed cable bushings are a prerequisite for correct functioning. In case of damage to the cord gasket in the housing cover it has to be repaired.

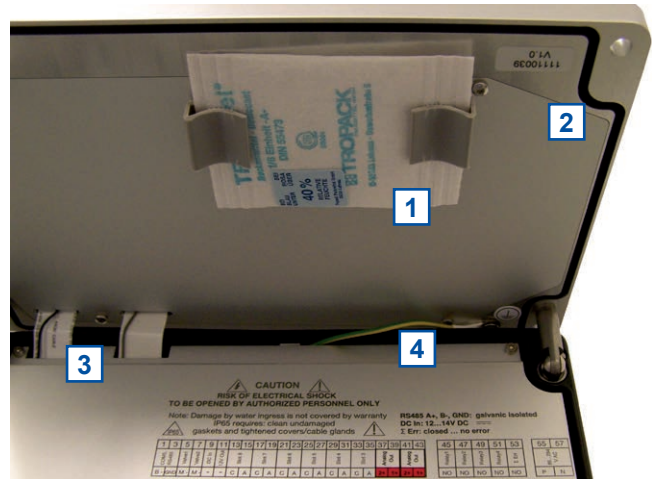

Used desiccant packages can be regenerated using normal drying processes (e.g. drying chamber at max 60°C or nitrogen). In this context, care must be taken that the cartridges cool down and are stored in an absolutely dry environment after the drying process.

Desiccant Packages are also available as spare parts (see section 11.3.1)

9.3 Housing

To ensure IP 65 grade protection, gaskets and case edges have to be checked for cleanliness, possible damage and dirt or foreign bodies before closing the housing cover every time. In case of damage to the cord gasket [2] in the housing cover it has to be repaired! Please ensure that the wires for the display [3] and the earth grounding [4] are positioned correctly (see picture above).

The cover must be tightly screwed (tightening torque 2.5 Nm) and the cable glands filled with cable or fitting plugs, must also be tight (tightening torque 2.5 Nm for 16 mm and 5 Nm for 20 mm). All sockets not in use (USB, MIL, etc.) must be covered with corresponding caps. Damage caused by intrusion of water will not be covered by the warranty.

9.4 Calibration Touch Screen

Every touch screen requires calibration so that each point on the touch surface is assigned to the corresponding spot on the display as accurately as possible.

Calibration has to be repeated if necessary because the touch screen properties may change due to environmental impacts, in particular repeated temperature fluctuations and ageing.

The touch screen calibration programme can be started up directly in `moni::tool`. For a description of the functionality, please refer to the manual `moni::tool`.

In case the `con::cube` can no longer be operated via its touch screen, the calibration procedure can be started via webbrowser, via VNC-Viewer or via mouse / keyboard connected to USB and the calibration can be carried out on the touch screen of the `con::cube`.

10 Troubleshooting

All information and notes regarding typical error pattern as well as error and status messages can be found in the manual of the operating software moni::tool.

10.1 Device Settings

The most important con::cube settings will be displayed when clicking on the s::can logo in the lower right hand side of the screen (see figure on the right).

10.2 Software Update

Please contact your s::can sales partner in case a software update is needed. In case the con::cube is connected to the internet there is a possibility for live update.

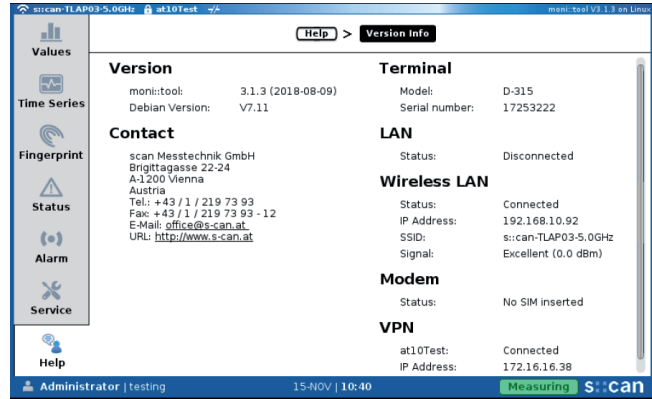

10.3 Return Consignment (RMA - Return Material Authorization)

Return consignments of the s::can monitoring system, or parts of the system, shall be done in a packaging that protects the device (original packaging or protective covering if possible). Before returning a consignment, you have to contact your s::can sales partner or s::can customer support (support@s-can.at). A RMA number will be assigned for each device, independent if the reason of the return consignment is service, repair or demo equipment.

RMA numbers can be requested from the s::can Customer Portal available on the s::can website directly. Return consignments without an RMA number will not be accepted. The customer always has to bear the costs for return consignment.

11 Accessories

11.1 Installation

11.1.1 Weather Shield

For protection of the con::cube in case of outdoor installation and for easy mounting on walls or railings a specific housing is available.

Name	Specification	Remark
Part-no.	F-51	
Housing material	stainless steel (1.4301)	
Dimensions	363 / 553 / 170 mm	W / H / D
Weight	5 kg	
Mounting bracket	2 x M8 U-bolt with screw nut and spring washer 4 x M5 flange nut	included in delivery for mounting onto rails

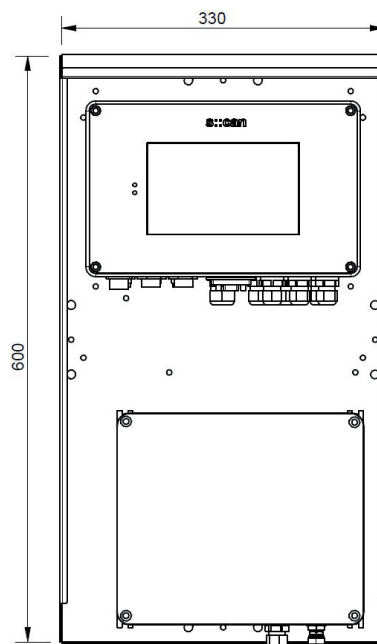
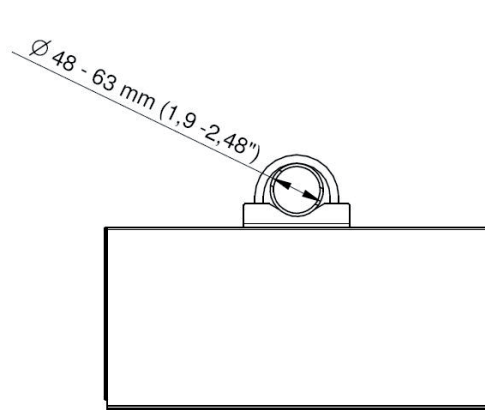

11.1.2 Power Supply Cord

For connection of the device to the power supply, a power supply cable is available.

Name	Specification	Remark
Part-no.	C-31-EU or C-31-US	
Cable length	2 m	
Weight	approx. 300 g	
Material	PU	jacket
Process connection	CEE-7 shockproof plug NEMA 5-15 plug	C-31-EU C-31-US
Environment rating (IP)	IP 44 IP 55	C-31-EU C-31-US



11.1.3 External Antenna and Connector

For a con::cube equipped with internal modem an external antenna is available. To connect this antenna to the con::cube a separate plug will be mounted.

Name	Specification	Remark
Part-no.	D-330-ANTENNA-PRO D-330-ANTENNA-PLUG	Antenna for 4G modem Plug for 4G modem
Cable length	3 m + 10 m extension cable	
Cable type	LL 195 Standard CFD200 (4.80 mm)	Antenna Extension cable
Dimension	325 / 36 / 155 mm 220 / 16 mm	W / H / D Length / diameter
Connection	RF-plug	
Frequency range	698 - 960 MHz 1710 - 2170 MHz 2500 - 2700 MHz	2G 3G 4G
Polarization	Linear	
Impedance	50 Ohm	
Environment rating (IP)	IP 67	
Operating temperature	-40 bis 85 °C (-40 bis 185 °F)	
Mounting	Wall mounting	stainless steel bracket

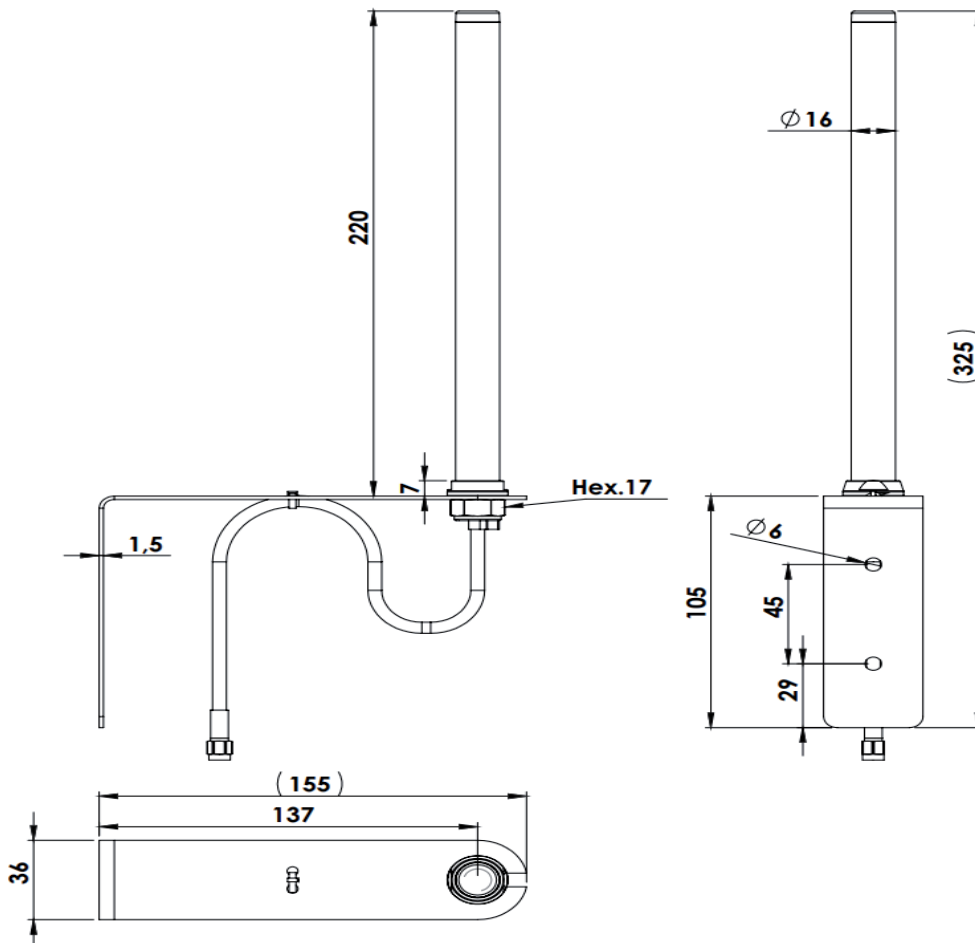

Name	Specification	Remark
Part-no.	D-315-ANTENNA-PRO D-315-ANTENNA-PLUG	Antenna Plug
Cable length	5 m + 10 m extension cable	
Cable type	MWC 6/50	
Weight	approx. 0.6 kg	Antenna
Dimension	35 x 756 mm 1060 mm	Diameter / length Length with fixation
Frequency range	800 / 900 / 1800 / 1900 / 2100 MHz	Omni-Directional
Radiation	H-360, V-30	
Polarization	Vertical	
Gain	7 dB	
VSWR	< 2.0 : 1	
Impedance	50 Ohm	
Environment rating (IP)	IP 67	
Operating temperature	-20 to 60 °C (-4 to 140 °F)	
Housing material	Aluminium	
Material other	Fiber glass	
Mounting	fixation included in deli- very	see instruction below

 Install antenna in area protected from lightning strikes! Antenna must be installed away from power lines in a distance equal to at least twice the combined length of the mast and antenna. Avoid to install antenna under large, overhanging tree branches.

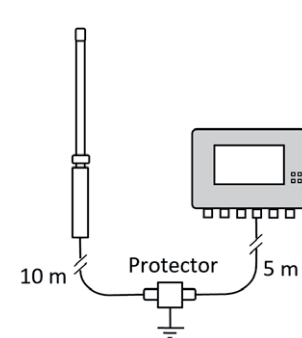
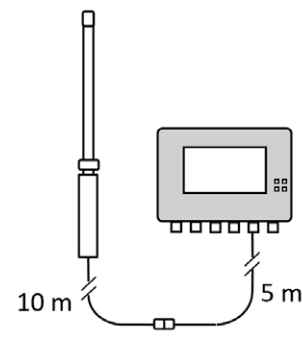
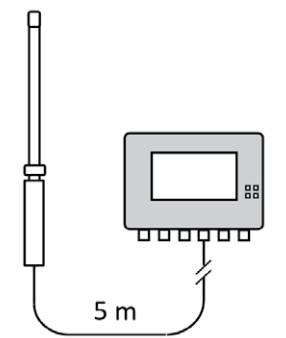
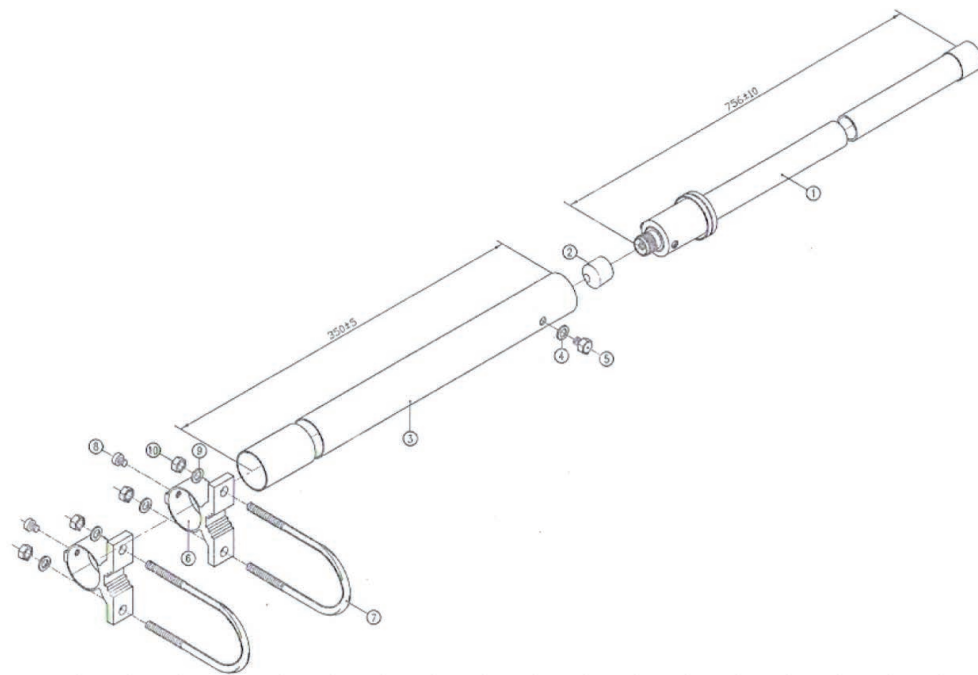

The mounting of the antenna is performed by the following steps:

- Fix carrier brackets on mounting console with bolts.
- Fix mounting console (antenna fixing hole should be on the top) to the desired place with round brackets.
- Antenna must be positioned vertically.
- Guide the cable through the mounting console.
- Remove the protective cap from the antenna plug and connect the cable to the antenna.
- For fixing the connector do not rotate the cable but only use the thread. Proper fixing for a connector is “finger tight” plus a quarter turn.
- Fix antenna “finger tight” with washer and bolt.
- Connect the cable to the con::cube.



For all outside installations the lightning protector has to be used. The protector must be attached to a grounded surface. It is a single-use device which means you should change it after lightning hits the antenna.



For any RF connector it is important to keep contacts clean. Gentle cleaning with isopropyl alcohol is allowed. Do not saturate connector with alcohol. Unused antenna connector should have a protective cap.

11.2 Automatic Cleaning

11.2.1 Cleaning Valve

For operation of the automatic compressed air cleaning system, a cleaning valve is available.

Name	Specification	Remark
Part-no.	B-44 B-44-2	
Cable length	2.5 m 1.0 m	B-44 B-44-2
Assembling	ex works, with cable end sleeves	+ blue - brown
Dimensions	85 / 75 / 70 mm	W / H / D
Material	Brass, stainless steel 1.4305 FPM	Housing Sealing material
Environment rating (IP)	IP 65	
Media that can be handled	neutral gases and liquids	
Temperature limits	-10 to 90°C (14 to 194°F) -30 to 60°C (-22 to 140°F)	of medium of environment
Operation voltage	12 VDC	supply by controller for operation

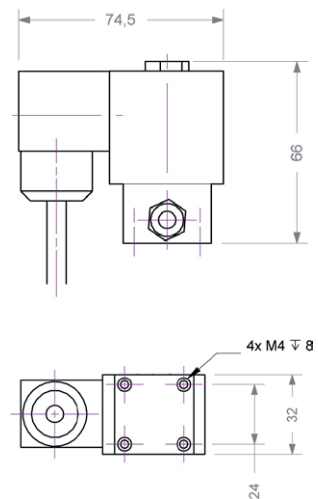

Name	Specification	Remark
Connection fitting compressed air side	B-44: Standard DIN 7.2 coupler B-44-2: coupler screw connection 6/4 mm, nickel-plated brass	<u>P</u> inlet pipe compressor (compressed air side)
Connection fitting probe side	B-44: Hose ID $\frac{3}{8}$ inch B-44-2: plug-in fitting (6 mm OD)	<u>A</u> inlet pipe probe (probe side)
Direct connection valve	$\frac{1}{8}$ inch	if fittings supplied ex works are removed

11.3 Spare Parts

11.3.1 Desiccant Package

To avoid condensing humidity inside the con::cube a desiccant package is built in. The desiccant packages are available as spare part.

Name	Specification	Remark
Part-no.	B-43-2	10 pieces
Dimensions	70 / 5 / 80 mm	W / H / D
Weight	approx. 10 g	



11.3.2 Touch Pen

For easy operation of the touch screen a touchscreen is included in delivery of the con::cube. Further touch pens can be ordered as spare part.

Name	Specification	Remark
Part-no.	D-312-PEN	3 pieces
Dimensions	87 mm	Length



11.4 Optional Features

The con::cube can be equipped with several optional features explained in the sections below. Regarding detailed information of the optional features please refer to the technical specifications located at the end of this manual.

 Installation of additional modules must be carried out by authorised persons only (see section 2) and after disconnecting the power supply! In addition a note containing further details for the installation is available on the s::can Customer Portal.

The installation of optional features is performed by the following steps:

- Power off the con::cube and ensure ESD protected environment.
- Loosen the four screws of the housing cover using a hexagon wrench size 5.
- Carefully lift up the housing cover a little bit. Do not lift too much to avoid pulling the flat ribbon cable out of the mounting bracket (see figure below).

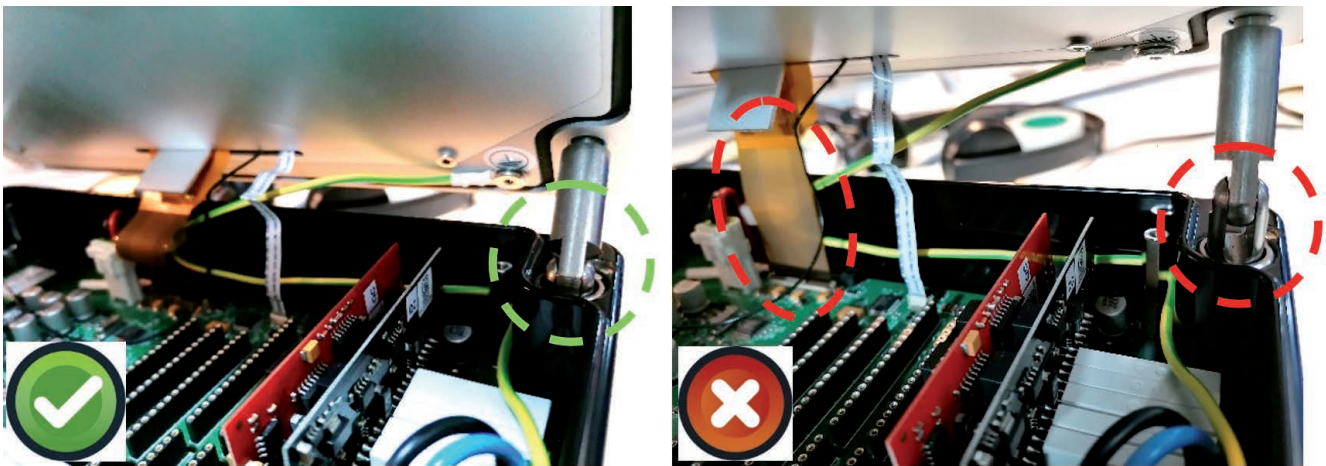

- Loosen the four Torx-T10 screws from the grey covering plate (see figure on the right).
- Carefully move off the covering plate including the retaining bracket. Take care not to loose any washers.

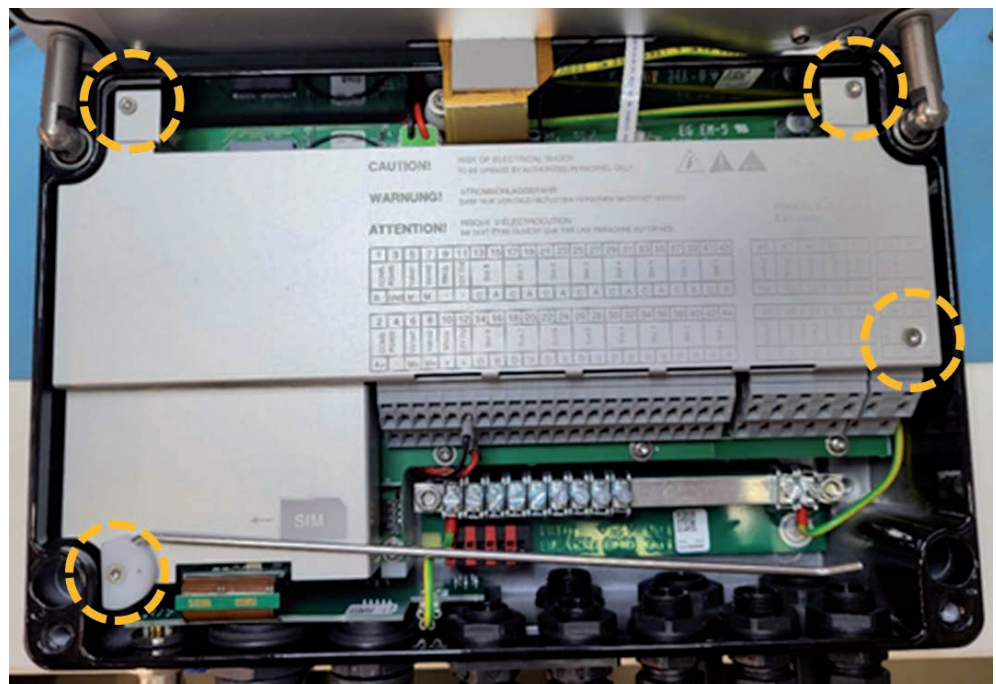

- Now the WLAN modem and the plug for the external 3G / 4G modem as well as the eight optional modules are visible (see yellow marking in the figure on the right).
- After performing the installation of the optional modules place the covering plate on the original position.
- Fasten the four Torx-T10 screws with max. 0.9 Nm.
- Close the housing cover and take special care not to pinch or buckle the flat ribbon cable or the grounding cable.
- Fasten the four screws of the housing cover.
- Power on the con::cube.

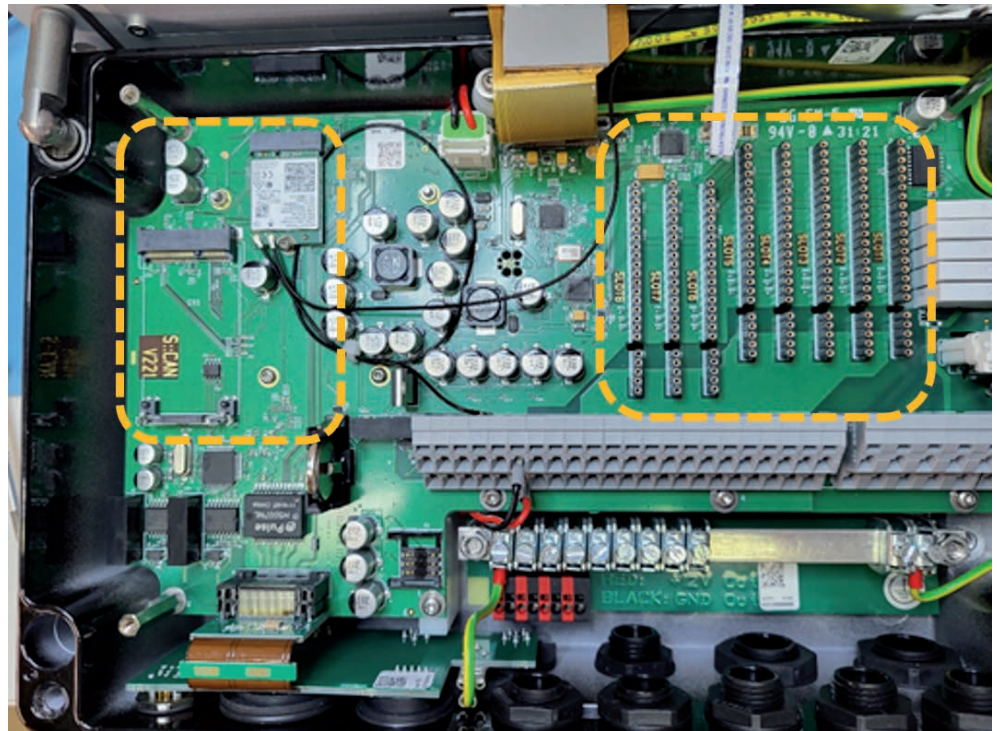

11.4.1 Gateway to 3G / 4G Modem

This optional available internal module provides wireless remote control and / or data transfer. The modem should be ordered at the same time as the con::cube to avoid later modification inside the con::cube.

Name	Specification	Remark
Part-no.	D-315-3GLX D-330-4GLX	3G modem 4G modem
Assembling	ex factory or on site by s::can Service	
Optional features	D-315-ANTENNA-PLUG D-315-ANTENNA-PRO D-330-ANTENNA-PLUG D-330-ANTENNA-PRO	



11.4.2 Analog Output Module

This optional module provides two analog outputs for data transfer to PLC systems.

Name	Specification	Remark
Part-no.	D-315-OUT-MA	
Output	2 x 0/4 - 20 mA	
Interface	AWG 28-12, stripped wire	via terminal block, see section 5.1 for correct wiring
Configuration	via moni::tool software	see section 12.1 for address mapping
Assembling	only by qualified personal authorized by s::can	con::cube can be equipped with max. 8 modules

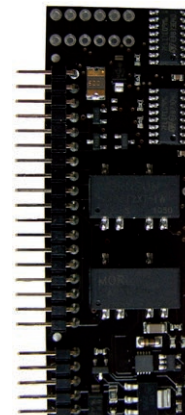

11.4.3 Digital Output Module

This optional module provides four configurable relay outputs for triggering functions.

Name	Specification	Remark
Part-no.	D-315-OUT-RELAY	
Output	4 x digital out	
Interface	AWG 28-12, stripped wire	via terminal block, see section 5.1 for correct wiring
Configuration	via moni::tool software	

11.4.4 Profibus DP Output Module

This optional module provides Profibus DP an interface for data transfer to PLC systems.

Name	Specification	Remark
Part-no.	D-315-OUT-PROFIBUS	
Output	Profibus DP	
Interface	Sub-D9, IP 67	via terminal block, see section 5.1 for correct wiring
Configuration	via moni::tool software	see section 12.2
Assembling	only by qualified personal authorized by s::can	con::cube can be equipped with 1 module at slot no. 8

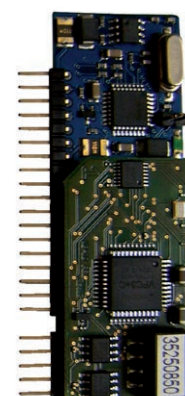

11.4.5 SDI 12 Output Module

This optional module provides SDI 12 an interface for data transfer to PLC systems.

Name	Specification	Remark
Part-no.	D-315-OUT-SDI12	
Interface		via terminal block, see section 5.1 for correct wiring
Configuration	via moni::tool software	
Assembling	only by qualified personal authorized by s::can	con::cube can be equipped with 1 module at slot no. 8

11.4.6 Analog Input Module

This optional module provides two analog inputs for integration of third party sensors into the s::can monitoring system.

Name	Specification	Remark
Part-no.	D-315-IN-MA	
Input	2 x 0/4 - 20 mA	
Interface	AWG 28-12, stripped wire	via terminal block, see section 5.1 for correct wiring
Configuration	via moni::tool software	see section 12.1 for address mapping
Assembling	only by qualified personal authorized by s::can	con::cube can be equipped with max. 8 modules

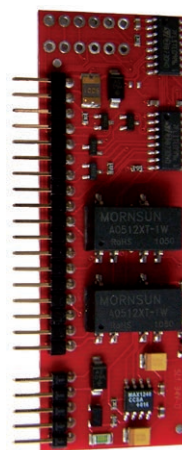

11.4.7 Digital Input Module

This optional module provides two digital inputs for integration of third party sensors into the s::can monitoring system.

Name	Specification	Remark
Part-no.	D-315-IN-RELAY	
Input	2 x digital in	
Interface	AWG 28-12, stripped wire	via terminal block, see section 5.1 for correct wiring
Configuration	via moni::tool software	see section 12.1 for address mapping
Assembling	only by qualified personal authorized by s::can	con::cube can be equipped with max. 8 modules

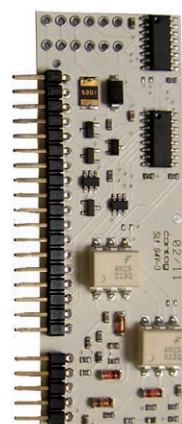

11.4.8 Connector Plug for external Antenna

In case the con::cube is not equipped with the new SMA antenna plug (D-330-ANTENNA-PLUG) yet, it can be installed at a later time.

Name	Specification	Remark
Part-no.	D-330-ANTENNA-PLUG	
SCope of delivery	SMA cable (200 mm) with plug and internal connection to 4G modem O-ring 16.5x1.5 mm	
Assembling	only by qualified personal authorized by s::can	
Needed tools	hexagon wrench no.5 Torx-TX10 wrench ope-end / ring wrench with 19 mm and 22 mm	housing cover cover plate cable gland

The antenna plug will be mounted instead of one cable gland. In the figure on the right is marked which cable glands can be used for mounting. Maybe the upper two cable glands are already blocked by the Profibus SUB D9 plug.



The installation of the antenna plug on the con::cube is performed by the following steps:

- See section 10.4. for how to open the con::cube.
- Remove one cable gland (see figure above) with help of a 19 mm and 22 mm wrench.
- Guide the SMA cable through the O-ring and place the O-ring in the groove of the antenna plug (see figure on the right).
- Mount the antenna plug in the free opening of the removed cable gland and fasten the M16 screw nut.
- Lay the SMA cable inside the con::cube as displayed on the right hand side and connect it to the 4G modem.
- Close the con::cube again properly (see section 10.4).

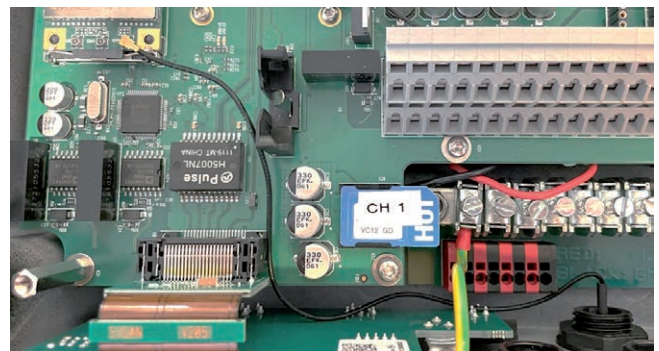

12 Technical Specifications

Name	Specification	Remark
Part-no.	D-330-230 D-330-024	con::cube with AC power supply con::cube with DC power supply
Dimensions housing	280 / 209 / 85 mm	W / H / D
Required space	290 / 280 / 240 mm	W / H / D
Weight	approx. 4 kg	
Operation temperature	-20 to 50 °C (-4 to 122 °F)	at max. temperature sun shield recommended
Storage temperature	-20 to 60 °C (-4 to 140 °F)	Acclimatised device to operation temperature before initial operation.
Humidity	5 to 90%	non-condensing
Material housing	Aluminium alloy, powder coated	
Environment rating (IP)	IP 65	see section 4.1
Environmental conditions	Altitude up to 2000 m Overvoltage category II Pollution degree 2	
Mounting	4 x M5 thread holes on backside 2 mounting brackets and 4 screws (included in delivery)	for direct mounting on panels (F-501) for wall mounting from front side
Power supply D-330-024	10 to 36 VDC	
Power supply D-330-230	100 to 240 VAC / 50 to 60 Hz	wide range power supply unit
Power supply cable	outside diameter 5 - 12 mm single cable wires 1.5 - 2.5 mm ²	min. 80°C min. 300 VAC
Required galvanic isolation of power input	3.0 kV 1.5 kV	D-330-230 D-330-024
Power consumption	1.5 W (typical) 10 W (typical) / 20 W (max.) 30 W (typical) / 60 W (max.)	in sleep mode no I/O ports fully equipped
Electric potential	Grounding for D-330-024 and D-330-230	max. 0.1 Ohm PE power supply to site's earth grounding max. 0.5 Ohm PE power supply to process medium; see section 5.5
Conformity - ECM	EN 61326-1	
Conformity - safety	EN 61010-1 UL 61010-1:2004 R10.08 CAN/CSA-C22.2 NO. 61010-1-04+G11 (R2009)	
Fuse	internal	replacement by s::can Service only
Internal battery	CR2032, 3V Lithium battery	for real time clock (RTC)
Connection of s::can spectrometer probe	1 x M12, IP 67 (RS485, 12 VDC, Ethernet) galvanically isolated 1 kV internal network termination 120 Ohm	
Connection of s::can ISE probes or s::can sensors	4 x sys plug connector, IP 67 (RS485, 12 VDC) galvanically isolated 1 kV internal network termination 120 Ohm	

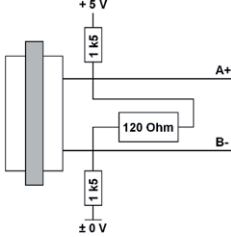
Name	Specification	Remark
RS485	galvanically isolated 1 kV internal network termination 120 Ohm	
Display	VGA TFT color display (800x480), 9 inches, (approx. 197 x 110 mm)	
User interface (on device itself)	USB (keyboard, mouse) Touch screen	
User interface (remote control)	Webbrowser (TCP/IP) VNC (TCP/IP)	
Network connection (TCP/IP)	WLAN / WIFI 802.11n a/b/g (300Mb/s) Ethernet LAN (100 Mb/s, RJ45) 3G or 4G modem (optional)	D-315-3GLX / D-330-4GLX
USB	USB connector (type A, 2.0)	for data transfer, software update, keyboard, mouse
Operating system	Linux	installed ex works (D-303-LX)
Main memory	2 GB RAM	
Onboard memory	16 GB	
Function display (LED)	4 x LED (blue / yellow / red)	blue = OK yellow = Servicemode active red = sum error
Interface to SCADA	Modbus RTU Modbus TCP	max. 32 parameters max. 32 parameters
Interface to SCADA (optional)	Profibus DP for max. 8 parameters (Slave according IEC 61158, up to 11 Mbit/s, DPV1, Baudrate bis 12 Mbaud)	D-315-OUT-PROFIBUS (blue module), address = 1, see section 11.4.4
	SDI 12 OUT for max. 8 parameters	D-315-OUT-SDI12 see section 11.4.5
	Analog OUT (4 to 20 mA active) Resolution = 12bit (5 µA) Accuracy = 30 µA Max. load = 500 Ohm, Galvanic isolation = 1 kV	D-315-OUT-MA (black module), see section 11.4.2
Interface to third party devices (optional)	Analog IN (4 to 20 mA) Input resistance = 100 Ohm Galvanic isolation = 1 kV Resolution = 12 bit (5 µA)	D-315-IN-mA (red module), see section 11.4.6
Digital OUT (optional) (relay on)	Max: 230 V / 500 VA (AC 15) 24 V / max. 2 A (DC 1) Min: 5 V / 100 mA	D-315-OUT-RELAY 4 modules normally open COM-3, address 33

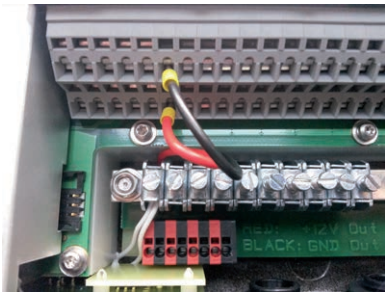
Name	Specification	Remark
Digital OUT sum error (relay on)	Max: 230 V / 500 VA (AC 15) 24 V / max. 2 A (DC 1) Min: 5 V / 100 mA	1 module normally open COM-3, address 33 LED: red = open, blue = closed
Digital IN	Logic levels: low < 5 V high > 10 V Max. voltage = 14 V Galvanic isolation > 1 kV	D-315-IN-RELAY (white module), see section 11.5.7
Digital OUT (relay change)	for 2 cleaning devices	
Power supply output 12 V	12 VDC, max. 8 W via red (+12 V) and black (-12 V) terminal block on bottom which are connected to the terminals 11 and 12 see picture on the right	

12.1 Terminal- and Address Assignment for optional I/O Modules

Slot	Terminal number for In- / Output 1 and 2	mA Output Address	mA Input Address	Digital Input Address
Slot 1	43 (+) / 44 (-) and 41 (+) / 42 (-)	49 and 50	17 and 18	33 and 34
Slot 2	39 (+) / 40 (-) and 37 (+) / 38 (-)	51 and 52	19 and 20	35 and 36
Slot 3	35 (+) / 36 (-) and 33 (+) / 34 (-)	53 and 54	21 and 22	37 and 38
Slot 4	31 (+) / 32 (-) and 29 (+) / 30 (-)	55 and 56	23 and 24	39 and 40
Slot 5	27 (+) / 28 (-) and 25 (+) / 26 (-)	57 and 58	25 and 26	41 and 42
Slot 6	23 (+) / 24 (-) and 21 (+) / 22 (-)	59 and 60	27 and 28	43 and 44
Slot 7	19 (+) / 20 (-) and 17 (+) / 18 (-)	61 and 62	29 und 30	45 and 46
Slot 8	15 (+) / 16 (-) and 13 (+) / 14 (-)	63 and 64	31 and 32	47 and 48

12.2 Pin Assignment for optional Profibus DP connector (Sub-D9)

Pin	Specification
1	not connected
2	not connected
3	PB +
4	not connected
5	Profibus GND
6	Profibus 5 V
7	not connected
8	PB -
9	not connected



s::can GmbH

Brigittagasse 22-24, 1200 Vienna, Austria
Tel.: +43 (0) 1 219 73 93 - 0
Fax: +43 (0) 1 219 73 93 - 12
office@s-can.at
www.s-can.at

