

# Helios PD2-6000 Analog Input Process Meter

## Instruction Manual



**HELIOS**



**MeterView Pro**

USB Install

- Large Display NEMA 4X, IP65 Wall Mounted Meter
- 0-20 mA, 4-20 mA, 0-5 V, 1-5 V, and  $\pm 10$  V Field Selectable Inputs with  $\pm 0.03\%$  Accuracy
- Large Dual-Line 6-Digit Display, 1.8" (46 mm) Readable from 100 Feet (30 Meters) Away
- Isolated 24 VDC @ 200 mA Transmitter Power Supply
- Easy Field Scaling in Engineering Units without Applying an Input
- 4 Relays with Interlocking Capability + Isolated 4-20 mA Output Option
- Free PC-Based, On-Board, MeterView Pro USB Programming Software
- SunBright Display Standard Feature; Great for Outdoor Applications
- Operating Temperature Range: -40 to 65°C (-40 to 149°F)
- Conformal Coated PCBs for Dust and Humidity Protection
- UL & C-UL Listed. E160849; 508 Industrial Control Equipment
- Input Power Options: 85-265 VAC / 90-265 VDC or 12-24 VDC / 12-24 VAC
- Display Input in Two Different Scales Simultaneously - Great for Level Applications
- Multi-Pump Alternation Control
- Round Horizontal Tank Function; Just Enter Diameter & Length
- 32-Point Linearization, Square Root Extraction and Programmable Exponent Function
- Programmable Display, Function Keys & Digital Inputs
- Tare Function
- On-Board RS-485 Serial Communications
- Modbus RTU Communication Protocol Standard
- 5 Digital Inputs & 4 Digital Outputs Standard
- Password Protection
- Light / Horn & Button Accessory
- Control Station Accessory for Remote Operation
- 3-Year Warranty

**PRECISION DIGITAL CORPORATION**

233 South Street • Hopkinton MA 01748 USA  
Tel (800) 343-1001 • Fax (508) 655-8990

[www.prediq.com](http://www.prediq.com)

**PRECISION  
DIGITAL**

**Disclaimer**

The information contained in this document is subject to change without notice. Precision Digital makes no representations or warranties with respect to the contents hereof and specifically disclaims any implied warranties of merchantability or fitness for a particular purpose. See Warranty Information and Terms & Conditions on [www.prediq.com](http://www.prediq.com) for complete details.

**CAUTION**

- Read complete instructions prior to installation and operation of the meter.

**WARNINGS**

- Risk of electric shock or personal injury.
- This product is not recommended for life support applications or applications where malfunctioning could result in personal injury or property loss. Anyone using this product for such applications does so at his/her own risk. Precision Digital Corporation shall not be held liable for damages resulting from such improper use.

**WARNING**

Cancer and Reproductive Harm - [www.P65Warnings.ca.gov](http://www.P65Warnings.ca.gov)

**Limited Warranty**

Precision Digital Corporation warrants this product against defects in material or workmanship for the specified period under "Specifications" from the date of shipment from the factory. Precision Digital's liability under this limited warranty shall not exceed the purchase value, repair, or replacement of the defective unit. See Warranty Information and Terms & Conditions on [www.prediq.com](http://www.prediq.com) for complete details.

**Registered Trademarks**

All trademarks mentioned in this document are the property of their respective owners.

© 2021 Precision Digital Corporation. All rights reserved.

**FREE MeterView Pro Programming Software**



*The meter can be powered from the USB connection. When using the USB connection, **DO NOT** apply AC or DC power to the meter.*

The easiest and quickest way to program your Helios meter is to use the FREE MeterView Pro programming software. This software is loaded into the meter and connects directly to your PC with a USB cable. We recommend that the first thing you do after taking the meter out of the box is connect the Helios to your PC with the provided USB cable – do not use a different cable. **DO NOT** apply AC or DC power to the meter while your PC is connected to the meter as it will disrupt the USB connection. You don't even have to apply an input signal.

MeterView Pro programming software is intuitive, and most customers can get their meter programmed as they like without even looking in the manual.

**Watch MeterView Pro Software Video at [www.prediq.com/meterviewpro](http://www.prediq.com/meterviewpro)**

In addition to programming, the software may be used for:

- Monitoring
- Datalogging using your PC
- Generating and saving programming files for later use

Once your meter is programmed the way you want it, you can wire it up for your application per the instructions in this manual and install it. If you find that you need to make adjustments to the programming after the meter is installed, you can use the programming buttons and the instructions in this manual to do so.

## Table of Contents

Introduction .....	6
Ordering Information .....	6
Specifications.....	9
General .....	9
Process Input.....	10
Relays .....	10
USB Connection .....	10
Isolated 4-20 mA Transmitter Output .....	11
RS-485 Serial Communications .....	11
Modbus® RTU Serial Communications.....	11
Digital Input (F4) .....	11
Digital Inputs & Outputs .....	11
MeterView Pro Software.....	11
Compliance Information.....	12
Safety.....	12
Safety Information .....	12
Installation .....	12
Unpacking .....	12
Wall Mounting Instructions .....	13
Mounting Dimensions.....	13
Conduit Holes Location .....	13
Pipe Mounting Instructions .....	14
Installation Overview.....	15
MeterView Pro Software.....	15
MeterView Pro Installation.....	15
Transmitter Supply Voltage Selection (P+, P-) .....	16
Connections.....	17
Connectors Labeling .....	17
Power Connections .....	18
Signal Connections .....	18
Relay Connections .....	18
Switching Inductive Loads.....	19
RS-485 Connections .....	19
RS-485 Multi-Drop Connection .....	19
RS-485 Serial Converters .....	19
Digital I/O Connections.....	20
F4 Digital Input Connections .....	21
4-20 mA Output Connections.....	21
Analog Output Power Supply .....	21
Remote Operation of Meter.....	21
Interlock Relay Feature .....	21
Setup and Programming .....	22
Overview.....	22
LED Status Indicators .....	22
Programming Buttons.....	23
Display Functions & Messages .....	24
Main Menu .....	25
Setting Numeric Values .....	26
Setting Up the Meter (SETUP) .....	26
Setting the Input Signal (INPUT).....	26
Setting the Display Units or Custom Tags (UNITS) .....	27
Setting the Decimal Point (DEC PT).....	27
Programming the Meter (PARAM) .....	28
Setting the Display Parameter & Intensity (DISPLAY) .....	30
Display Intensity (d-INTY).....	30

<b>Setting the Relay Operation (rELRY)</b> .....	<b>31</b>
Setting the Relay Action .....	31
Programming Set and Reset Points .....	32
Setting Fail-Safe Operation .....	32
Programming Time Delay.....	32
Relay Action for Loss of 4-20 mA Input (Loop Break) .....	32
<b>Relay and Alarm Operation Diagrams</b> .....	<b>32</b>
High Alarm Operation (Set > Reset) .....	32
Low Alarm Operation (Set < Reset) .....	33
High Alarm with Fail-Safe Operation (Set > Reset).....	33
Low Alarm with Fail-Safe Operation (Set < Reset) .....	33
Time Delay Operation .....	33
Pump Alternation Control Operation .....	34
Relay Sampling Operation .....	34
<b>Relay Operation Details</b> .....	<b>35</b>
Overview .....	35
Relays Auto Initialization .....	35
Fail-Safe Operation .....	35
Front Panel LEDs.....	35
Latching and Non-Latching Relay Operation .....	35
Non-Latching Relay (RlEtO) .....	36
Non-Latching Relay with Manual Reset (R-nRn).....	36
Latching Relay (LRtCH) .....	36
Latching Relay with Clear (LR-Clr) .....	36
Acknowledging Relays .....	37
Pump Alternation Control Applications (RlEtErn) .....	37
Setting Up the Interlock Relay (Force On) Feature .....	38
<b>Scaling the 4-20 mA Analog Output (Rout)</b> .....	<b>39</b>
<b>Reset Menu (rESEt)</b> .....	<b>39</b>
<b>Manual Control Menu (Control)</b> .....	<b>39</b>
<b>Setting Up the Password (PR55)</b> .....	<b>40</b>
Protecting or Locking the Meter .....	40
Making Changes to a Password Protected Meter .....	40
Disabling Password Protection.....	40
<b>Advanced Features Menu</b> .....	<b>41</b>
Advanced Features Menu & Display Messages.....	41
Noise Filter (FiltEr).....	42
Noise Filter Bypass (bYPR55).....	42
Rounding Feature (round) .....	42
Modbus RTU Serial Communications (5ErRl).....	42
Select Menu (SELEct).....	43
Input Signal Conditioning (FuncEtion).....	43
Low-Flow Cutoff (LwEtOFF).....	44
Analog Output Programming (RoutPr) .....	44
Programmable Function Keys User Menu (u5Er).....	45
Tare (tRrE).....	45
Internal Source Calibration (iRl) .....	46
<b>Meter Operation</b> .....	<b>47</b>
<b>Button Operation</b> .....	<b>47</b>
<b>Function Keys Operation</b> .....	<b>47</b>
<b>Digital Inputs Operation</b> .....	<b>47</b>
<b>Maximum/Minimum Readings</b> .....	<b>47</b>
<b>Troubleshooting</b> .....	<b>48</b>
<b>Diagnostics Menu (dRl)</b> .....	<b>48</b>
Testing the Display LEDs.....	48
Determining Software Version.....	48
<b>Reset Meter to Factory Defaults</b> .....	<b>48</b>
Factory Defaults & User Settings .....	49
<b>Troubleshooting Tips</b> .....	<b>50</b>

## Table of Figures

Figure 1. Meter Mounting Holes Location .....	13
Figure 2. Meter Mounting Holes Dimensions .....	13
Figure 3. Meter Dimensions – Side View .....	13
Figure 4. Meter Dimensions - Front View .....	13
Figure 5. Conduit Holes Location – Bottom View .....	13
Figure 5. Vertical Pipe Mount Assembly.....	14
Figure 6. Horizontal Pipe Mount Assembly .....	14
Figure 7. Transmitter Supply Voltage Selection .....	16
Figure 8. PD2-6000-6H0 / 7H0 Connectors Label .....	17
Figure 9. PD2-6000-6H7 / 7H7 Connectors Label .....	17
Figure 10. Power Connections .....	18
Figure 11. Transmitters Powered by Internal Supply .....	18
Figure 12. Transmitter Powered by External Supply or Self-Powered .....	18
Figure 13. Voltage Input Connections .....	18
Figure 14. Relay Connections.....	18
Figure 15. AC and DC Loads Protection.....	19
Figure 16. Low Voltage DC Loads Protection .....	19
Figure 17. RS-485 Connection .....	19
Figure 18. Five-Wire RS-485 Connections.....	20
Figure 19. Three-Wire RS-485 Multi-Drop Connections .....	20
Figure 20. Connections for RS-485 Connector to Serial Converter .....	20
Figure 21. Three-Wire RS-485 Connection .....	20
Figure 22. Digital Input and Output Connections .....	20
Figure 23. F4 Digital Input Connections .....	21
Figure 24. 4-20 mA Output Connections .....	21
Figure 25. Analog Output Supply Powering Other Devices.....	21
Figure 26. Meter to PDA2364-MRUE Control Station Connection.....	21
Figure 27. Interlock Connections .....	21

## Introduction

The Helios PD2-6000 is a multi-purpose, easy to use, large-display digital process meter ideal for level, flow rate, temperature, or pressure transmitter applications. It features large 1.8 inch superluminous LED digits, which can be read in direct sunlight from up to 100 feet (30 meters) away. It is housed in a water-resistant, field-mountable NEMA 4X/IP65 rated enclosure for convenient indoor and outdoor installation.

The programming buttons are located behind the lower panel door and are not generally accessible during operation. For that reason, we recommend the use of the PDA2364-MRUE remote control station which has four buttons to mimic the buttons behind the panel.

The meter accepts current and voltage signals (e.g. 4-20 mA, 0-10 V). Three of the programming buttons can be set for custom operation. The analog input can be scaled to display the process in two different scales; for example, the main display could indicate level in feet and the second display could indicate the volume in gallons.

A fully loaded Helios PD2-6000 meter comes with four SPDT relays, a 4-20 mA output, two 24 VDC power supplies, five digital inputs and four digital outputs, and RS-485 serial communications.

The four relays can be used for alarm indication or process control applications such as pump alternation control. The 4-20 mA isolated output, Modbus RTU serial communications, and digital I/O features make the Helios an excellent addition to any system.

## Ordering Information

### 85-265 VAC Models

Model	Standard Features	Options Installed
PD2-6000-6H0	5 Digital Inputs, 4 Digital Outputs, RS-485 Communications	No options
PD2-6000-6H7		4 relays 4-20 mA output

### 12-24 VDC Models

Model	Standard Features	Options Installed
PD2-6000-7H0	5 Digital Inputs, 4 Digital Outputs, RS-485 Communications	No options
PD2-6000-7H7		4 relays 4-20 mA output

### Accessories

Model	Description
<a href="#">PDA0004</a>	Cable Gland
<a href="#">PDA7485-I</a>	RS-232 to RS-485 isolated converter
<a href="#">PDA8485-I</a>	USB to RS-485 isolated converter
<a href="#">PDAPLUG2</a>	Plastic Conduit Plug
<a href="#">PDX6901</a>	Snubber: 0.01 $\mu$ F/470 $\Omega$ , 250 VAC

### PDA2360 Control Stations



Model	Description
<a href="#">PDA2360-E</a>	Emergency button
<a href="#">PDA2361-A</a>	Ack button
<a href="#">PDA2361-B</a>	Blank button
<a href="#">PDA2361-R</a>	Reset button
<a href="#">PDA2361-T</a>	Tare button
<a href="#">PDA2361-S</a>	Stop button
<a href="#">PDA2361-Q</a>	Silence button
<a href="#">PDA2362-AR</a>	Ack and Reset buttons
<a href="#">PDA2362-BB</a>	Two blank buttons
<a href="#">PDA2364-MRUE</a>	Menu, right, up, enter buttons

Note: Control stations can be connected directly to the Helios meter's on-board digital inputs. See *Remote Operation of Meter* on page 21 for details.

**Light / Horn & Button Accessories**



Helios Meter Shown with MOD-PD2LHRB1 Red Light / Horn and Button. Meter Sold Separately.

Model	Description
<a href="#">MOD-PD2LHRB1</a>	Red Light / Horn and Button Mounted and Wired to Helios <sup>(1)</sup>
<a href="#">MOD-PD2LHGB1</a>	Green Light / Horn and Button Mounted and Wired to Helios <sup>(1)</sup>
<a href="#">MOD-PD2LHYB1</a>	Yellow Light / Horn and Button Mounted and Wired to Helios <sup>(1)</sup>
<a href="#">MOD-PD2LHBB1</a>	Blue Light / Horn and Button Mounted and Wired to Helios <sup>(1)</sup>
<a href="#">MOD-PD2LHWB1</a>	White Light / Horn and Button Mounted and Wired to Helios <sup>(1)</sup>
<a href="#">MOD-PD2LH5CB1</a>	Light / Horn with User Choice of Red, Green, Yellow, Blue or White Light, Button, Mounted and Wired to Helios <sup>(1)</sup>
<a href="#">MOD-PD2LH3CB1-RYG</a>	Light / Horn with Red, Yellow, Green Light Layers, Button, Mounted and Wired to Helios <sup>(1)</sup>

Note:

- Specify MOD-PD2LH model as a separate item on the order for the Helios to order the Light / Horn & Button accessory installed and wired. Meter is sold separately.



9 labels are provided for the button.

**Pipe Mounting Kit**



Helios Meter Shown mounted to pipe using PDA6260 pipe mounting kit. See *Pipe Mounting Instructions* on page 14 for details.

Model	Description
<a href="#">PDA6260</a>	2" Pipe Mounting Kit for PD2

**Signal Splitter & Conditioner Accessories**



Model	Description
<a href="#">PD659-1MA-1MA</a>	Signal Isolator with One 4-20 mA Input and One 4-20 mA Output
<a href="#">PD659-1MA-2MA</a>	Signal Splitter with One 4-20 mA Input and Two 4-20 mA Outputs
<a href="#">PD659-1V-1MA</a>	Signal Conditioner with One 0-10 VDC Input and One 4-20 mA Output
<a href="#">PD659-1MA-1V</a>	Signal Conditioner with One 4-20 mA Input and One 0-10 VDC Output

**PDA6420 Split Core AC Current Transducer**



Model	Description
<a href="#">PDA6420</a>	Input: 30/60/120 AAC; Output: 4-20 mA

Note: The PDA6420 may be useful for customers that want to convert their AC Current reading to a 4-20 mA signal and display it on a meter that accepts a 4-20 mA input.



## Useful Tools

### PD9501 Multi-Function Calibrator



This [PD9501](#) Multi-Function Calibrator has a variety of signal measurement and output functions, including voltage, current, thermocouple, and RTD.

### PD9502 Low-Cost Signal Generator



The [PD9502](#) is a low-cost, compact, simple to use 4-20 mA or 0-10 VDC signal generator. It can easily be set for 0-20 mA, 4-20 mA, 0-10 V or 2-10 V ranges. Signal adjustment is made with a one-turn knob. A 15-27 VDC wall plug is provided with the instrument. Optional USB power bank is available.



## Specifications

Except where noted all specifications apply to operation at +25°C.

### General

<b>Display</b>	Dual-line: 1.8" (46 mm) high, red LEDs 6 digits per line (-99999 to 999999), with lead zero blanking
<b>Display Intensity</b>	Eight user selectable intensity levels. Default value is six.
<b>Display Update Rate</b>	5/second (200 ms)
<b>LED Status Indicators</b>	See <i>LED Status Indicators</i> on page 22 for details.
<b>Overrange</b>	Display flashes 999999
<b>Underrange</b>	Display flashes -99999
<b>Display Assignment</b>	Display Line 1: PV1, PV2, PCT, PV & units, gross weight, net & gross weight, max/min, max & min, set points, or Modbus input. Display Line 2: Same as Display Line 1; plus units, tag or turned off.
<b>Programming Methods</b>	Four programming buttons, digital inputs, PC and MeterView Pro software, or Modbus registers.
<b>Noise Filter</b>	Programmable from 2 to 199 (0 will disable filter)
<b>Filter Bypass</b>	Programmable from 0.1 to 99.9% of calibrated span
<b>Recalibration</b>	All ranges are calibrated at the factory. Recalibration is recommended at least every 12 months.
<b>Max/Min Display</b>	Max/min readings reached by the process are stored until reset by the user or until power to the meter is turned off.
<b>Rounding</b>	Select 1, 2, 5, 10, 20, 50, or 100 (e.g. rounding = 10, value = 123.45, display = 123.50).
<b>Tare</b>	Tare function zeros out the meter to remove the weight of a container. Tare function can be assigned to a function key, F4 terminal, or a digital input.
<b>Password</b>	Three programmable passwords restrict modification of programmed settings. Pass 1: Allows use of function keys and digital inputs Pass 2: Allows use of function keys, digital inputs and editing set/reset points Pass 3: Restricts all programming, function keys, and digital inputs.
<b>Non-Volatile Memory</b>	All programmed settings are stored in non-volatile memory for a minimum of ten years if power is lost.
<b>Power Options</b>	85-265 VAC 50/60 Hz; 90-265 VDC, 20 W max; 12-24 VDC, 12-24 VAC, 15 W max. Powered over USB for configuration only.
<b>Fuse</b>	Required external fuse: UL Recognized, 5 A max, slow blow; up to 6 meters may share one 5 A fuse

<b>Normal Mode Rejection</b>	Greater than 60 dB at 50/60 Hz
<b>Isolation</b>	4 kV input/output-to-power line 500 V input-to-output or output-to-P+ supply
<b>Overvoltage Category</b>	Installation Overvoltage Category II: Local level with smaller transient overvoltages than Installation Overvoltage Category III.
<b>Environmental</b>	Operating temperature range: -40 to 65°C (-40 to 149°F) Storage temperature range: -40 to 85°C (-40 to 185°F) Relative humidity: 0 to 90% non-condensing <i>Note: Printed circuit boards are conformally coated.</i>
<b>Connections</b>	Power, signal, relays, mA out: Removable screw terminal blocks accept 12 to 22 AWG wire. RS-485: Removable screw terminal block accepts 16 to 30 AWG wire. Digital I/O: Non-removable screw terminal blocks accept 16 to 30 AWG wire.
<b>Enclosure</b>	UL Type 4X, IP65 rated. Polycarbonate & glass blended plastic case, color: gray. Includes four PG11 through-hole conduit openings, with two factory installed PG11, IP68, black nylon threaded hole plugs with backing nuts.
<b>Mounting</b>	Wall Mounting: Four (4) mounting holes provided for mounting meter to wall. See <i>Wall Mounting Instructions</i> on page 13 for additional details. Pipe Mounting: Optional pipe mounting kit (PDA6260) allows for pipe mounting. Sold separately. See <i>Pipe Mounting Instructions</i> on page 14 for additional details.
<b>Tightening Torque</b>	Power, signal, relays, mA out terminals: 5 lb-in (0.56 Nm) Digital I/O and RS-485: 2.2 lb-in (0.25 Nm)
<b>Overall Dimensions</b>	10.63" x 12.59" x 4.77" (270 mm x 319.7 mm x 121.2 mm) (W x H x D)
<b>Weight</b>	6.10 lbs (2.76 kg)
<b>Warranty</b>	3 years parts & labor. See Warranty Information and Terms & Conditions on <a href="http://www.predig.com">www.predig.com</a> for complete details.

## Process Input

<b>Inputs</b>	Field selectable: 0-20 mA, 4-20 mA ±10 V (0-5 V, 1-5 V, 0-10 V) Modbus PV (Slave)	
<b>Isolated Transmitter Power Supply</b>	Terminals P+ & P-: 24 VDC ±10%. All models selectable for 24, 10, or 5 VDC supply (Switch labeled P+/P-). 85-265 VAC models rated @ 200 mA max, 12-24 VDC powered models rated @ 100 mA max. 5 & 10 VDC supply rated @ 50 mA max. Refer to <i>Transmitter Supply Voltage Selection (P+, P-)</i> on page 16. When the Light / Horn is powered by the transmitter power supply, see MOD-PD2LH Light / Horn's transmitter power supply specification in MOD-PD2LH manual for additional details. Light / Horn power not available for 5 or 10 VDC supplies.	
<b>Accuracy</b>	±0.03% of calibrated span ±1 count, square root & programmable exponent accuracy range: 10-100% of calibrated span	
<b>Temperature Drift</b>	0.005% of calibrated span/°C max from 0 to 65°C ambient, 0.01% of calibrated span/°C max from -40 to 0°C ambient	
<b>Input Signal Conditioning</b>	Linear, square root, programmable exponent, or round horizontal tank volume calculation	
<b>Multi-Point Linearization</b>	2 to 32 points for PV or PV1 2 to 8 points for PV2 (Dual-scale Level feature)	
<b>Programmable Exponent</b>	User selectable from 1.0001 to 2.9999 for open channel flow	
<b>Round Horizontal Tank</b>	Diameter & Length: 999.999 inch or cm calculates volume in gallons or liters respectively.	
<b>Low-Flow Cutoff</b>	0.1 to 999,999 (0 disables cutoff function). Point below at which display always shows zero.	
<b>Decimal Point</b>	Up to five decimal places or none: <i>dddddd, dddddd, dddd, ddd, dd, or dddddd</i>	
<b>Calibration Range</b>	Input Range	Minimum Span Input 1 & 2
	4-20 mA	0.15 mA
	±10 V	0.10 V
	An error message will appear if the input 1 and input 2 signals are too close together.	
<b>Input Impedance</b>	Voltage ranges: greater than 500 kΩ Current ranges: 50 - 100 Ω (depending on internal resettable fuse impedance)	
<b>Input Overload</b>	Current input protected by an internal resettable fuse, 30 VDC max. Fuse resets automatically after fault is removed.	
<b>HART Transparency</b>	The meter does not interfere with existing HART communications; it displays the 4-20 mA primary variable and it allows the HART communications to pass through without interruption. The meter is not affected if a HART communicator is connected to the loop. The meter does not display secondary HART variables.	

## Relays

<b>Rating</b>	4 SPDT (Form C) internal and rated 3 A @ 30 VDC and 125/250 VAC resistive load; 1/14 HP (≈ 50 W) @ 125/250 VAC for inductive loads
<b>Noise Suppression</b>	Noise suppression is recommended for each relay contact switching inductive loads. See <i>Switching Inductive Loads</i> on page 19 for details.
<b>Deadband</b>	0-100% of span, user programmable
<b>High or Low Alarm</b>	User may program any alarm for high or low trip point. Unused alarm LEDs and relays may be disabled (turn off).
<b>Relay Operation</b>	<ul style="list-style-type: none"> <li>Automatic (non-latching) and/or manual reset</li> <li>Latching (requires manual acknowledge) with or without clear</li> <li>Pump alternation control (2-4 relays)</li> <li>Sampling (based on set point and time)</li> <li>Off (disable unused relays and enable Interlock feature)</li> <li>Manual on/off control mode</li> </ul>
<b>Relay Reset (Acknowledge)</b>	User selectable via front panel button, F4 digital input, external contact closure on digital inputs, or through serial communications.
<b>Time Delay</b>	0 to 999.9 seconds, on & off relay time delays. Programmable and independent for each relay
<b>Fail-Safe Operation</b>	Programmable and independent for each relay. <i>Note: Relay coil is energized in non-alarm condition. In case of power failure, relay will go to alarm state.</i>
<b>Auto Initialization</b>	When power is applied to the meter, relays will reflect the state of the input to the meter.

## USB Connection

<b>Function</b>	Programming only
<b>Compatibility</b>	USB 2.0 Standard, Compliant
<b>Connector Type</b>	Type B receptacle
<b>Cable</b>	USB Type A-B cable
<b>Driver</b>	Microsoft® Windows® XP/Vista/7/8/10
<b>Power</b>	USB port provides power to the meter. <b>DO NOT</b> apply AC or DC power to the meter while the USB port is in use.

## Isolated 4-20 mA Transmitter Output

<b>Output Source</b>	Process variable (PV), max, min, set points 1-4, Modbus input, or manual control mode		
<b>Scaling Range</b>	1.000 to 23.000 mA for any display range		
<b>Calibration</b>	Factory calibrated: 4.000 to 20.000 = 4-20 mA output		
<b>Analog Out Programming</b>	23.000 mA maximum for all parameters: Overrange, underrange, max, min, and break		
<b>Accuracy</b>	± 0.1% of span ± 0.004 mA		
<b>Temperature Drift</b>	0.4 µA/°C max from 0 to 65°C ambient, 0.8 µA/°C max from -40 to 0°C ambient <i>Note: Analog output drift is separate from input drift.</i>		
<b>Isolated Transmitter Power Supply</b>	Terminals I+ & R: 24 VDC ±10%. May be used to power the 4-20 mA output or other devices. All models rated @ 40 mA max.		
<b>External Loop Power Supply</b>	35 VDC maximum		
<b>Output Loop Resistance</b>	Power supply	Minimum	Maximum
	24 VDC	10 Ω	700 Ω
	35 VDC (external)	100 Ω	1200 Ω
<b>Additional 4-20 mA Outputs</b>	The <a href="#">PD659-1MA-2MA</a> can split the optional 4-20 mA output into two isolated 4-20 mA outputs		
<b>0-10 VDC Output</b>	The <a href="#">PD659-1MA-1V</a> can convert the optional 4-20 mA output to a 0-10 VDC output		

## RS-485 Serial Communications

<b>Compatibility</b>	EIA-485
<b>Connectors</b>	Removable screw terminal connector
<b>Max Distance</b>	3,937' (1,200 m) max
<b>Status Indication</b>	Separate LEDs for Power (P), Transmit (TX), and Receive (RX)

## Modbus® RTU Serial Communications

<b>Slave Id</b>	1 – 247 (Meter address)
<b>Baud Rate</b>	300 – 19,200 bps
<b>Transmit Time Delay</b>	Programmable between 0 and 199 ms
<b>Data</b>	8 bit (1 start bit, 1 or 2 stop bits)
<b>Parity</b>	Even, Odd, or None with 1 or 2 stop bits
<b>Byte-To-Byte Timeout</b>	0.01 – 2.54 second
<b>Turn Around Delay</b>	Less than 2 ms (fixed)

*Note: Refer to the Helios Modbus Register Tables located at [www.prediq.com](http://www.prediq.com) for details.*

## Digital Input (F4)

<b>Function</b>	Remote operation of front-panel buttons, acknowledge/reset relays, reset max/min values. See <i>Function Keys &amp; Digital I/O Available Settings</i> on page 45 for a complete list of capabilities.
<b>Contacts</b>	3.3 VDC on contact. Connect normally open contacts across F4 to COM
<b>Logic Levels</b>	Logic High: 3 to 5 VDC Logic Low: 0 to 1.25 VDC

## Digital Inputs & Outputs

<b>Function</b>	Terminals provided for remote operation of all four programming / operation buttons (use <a href="#">PDA2364-MRUE</a> control station). Other uses include acknowledge/reset relays and reset max/min values. See <i>Function Keys &amp; Digital I/O Available Settings</i> on page 45 for a complete list of capabilities.
<b>Channels</b>	4 digital inputs & 4 digital outputs
<b>Digital Input Logic High</b>	3 to 5 VDC
<b>Digital Input Logic Low</b>	0 to 1.25 VDC
<b>Digital Output Logic High</b>	3.1 to 3.3 VDC
<b>Digital Output Logic Low</b>	0 to 0.4 VDC
<b>Source Current</b>	10 mA maximum output current
<b>Sink Current</b>	1.5 mA minimum input current
<b>+5 V Terminal</b>	To be used as pull-up for digital inputs only. Connect normally open push buttons across +5 V & DI 1-4.

### WARNING

- **DO NOT** use +5 V terminal to power external devices.

## MeterView Pro Software

<b>Availability</b>	Download directly from meter or from <a href="http://www.prediq.com/download_software">www.prediq.com/download_software</a>
<b>System Requirements</b>	Microsoft® Windows® XP/Vista/7/8/10
<b>Communications</b>	USB 2.0 (for programming only) (Standard USB A to USB Type B) RS-485 to USB converter (programming, monitoring, and data logging)
<b>Configuration</b>	Configure meters one at a time
<b>Power</b>	USB port provides power to the meter. <b>DO NOT</b> apply AC or DC power to the meter while the USB port is in use.

## Compliance Information

### Safety

<b>UL &amp; C-UL Listed</b>	USA & Canada UL 508 Industrial Control Equipment (USA) C22.2 No. 142 (Canadian National Standard)
<b>UL File Number</b>	E160849
<b>Enclosure</b>	UL Type 4X, NEMA 4X, IP65
<b>Low Voltage Directive</b>	EN 61010-1 Safety requirements for measurement, control, and laboratory use

## Safety Information

### ⚠ CAUTION

- Read complete instructions prior to installation and operation of the meter.

### ⚠ WARNINGS

- Risk of electric shock or personal injury.
- Hazardous voltages exist within enclosure. Installation and service should be performed only by trained service personnel.

## Installation

There is no need to open the clear plastic front cover in order to complete the installation, wiring, and setup of the meter. All programming is done using [MeterView Pro](#) software or through the buttons and switches located under the lower door panel and are accessible by removing the single securing screw. Wires should be run through the knockout holes located on the bottom of the meter, see *Figure 5. Conduit Holes Location – Bottom View* on page 13 for details.

There are a total of four pre-drilled conduit entry holes located at the bottom of the meter. If the need to drill additional holes arises, make sure you will have the clearance necessary for conduit mounting hardware.

Do not disconnect the RJ45 connector found on the right side of the meter wiring board. Doing so will disable the on-board digital I/O, RS-485 serial communications, and M-Link functionality.

Instructions are provided for changing the transmitter power supply to output 5 or 10 VDC instead of 24 VDC, see *Figure 8. Transmitter Supply Voltage Selection* on page 16.

## Unpacking

Remove the meter from box. Inspect the packaging and contents for damage. Report damages, if any, to the carrier.

If any part is missing or the meter malfunctions, please contact your supplier or the factory for assistance.

### Wall Mounting Instructions

The meter can be mounted to any wall using the four provided mounting holes. Note that the bottom mounting holes are located underneath the lower door panel. To mount the meter to a wall, follow these instructions

- Prepare a section of wall approximately 11" x 13" (280 mm x 330 mm) for meter mounting by marking with a pencil the mounting holes (shown in *Figure 1*) on the wall.
- Select the appropriate mounting screws for the mounting surface to be used. The mounting holes diameter is shown on *Figure 2*.  
*Note: Mounting screws are not included.*
- Using a drill bit slightly smaller than the girth of the mounting screws, pre-drill holes at the mounting locations previously marked.
- Insert mounting screws into the four mounting holes and screw them into the pre-drilled holes. **DO NOT** overtighten the mounting screws as it is possible that the enclosure could crack and become damaged.

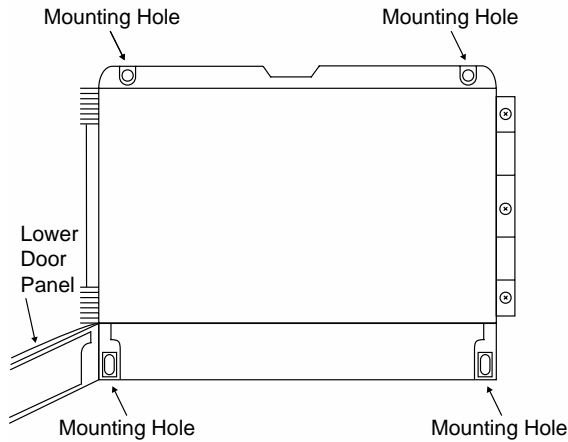

Figure 1. Meter Mounting Holes Location

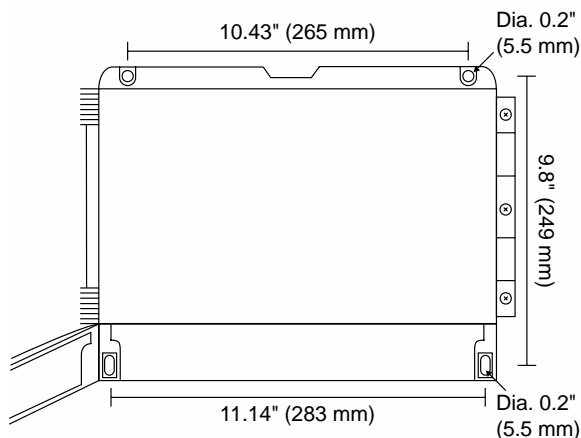

Figure 2. Meter Mounting Holes Dimensions

### Mounting Dimensions

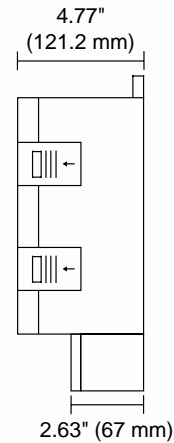

Figure 3. Meter Dimensions – Side View

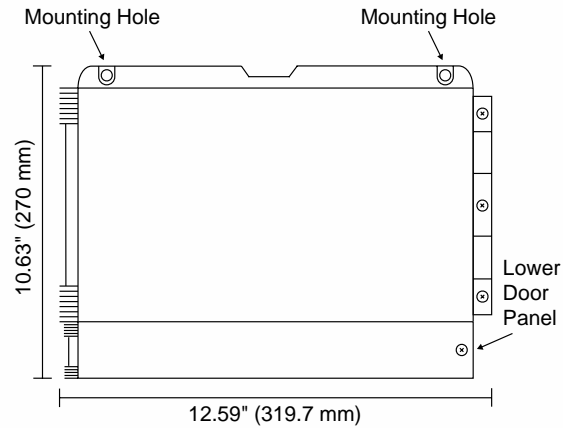

Figure 4. Meter Dimensions - Front View

### Conduit Holes Location

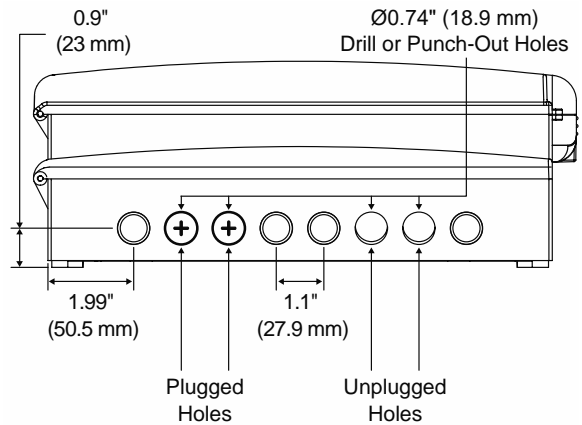

Figure 5. Conduit Holes Location – Bottom View

### Pipe Mounting Instructions

The meter can also be mounted to a pipe using the optional pipe mounting kit ([PDA6260](#)). This kit includes two mounting plates, two U-bolts, and the necessary nuts and bolts. To mount the meter to a pipe using the pipe mounting kit accessory, follow these instructions.

- Secure the mounting plates to the top and bottom (for vertical pipes) or left and right (for horizontal pipes) of the reverse side of the meter enclosure using the provided fasteners. **DO NOT** overtighten the fasteners as it could cause damage to the enclosure.
- Using the provided nuts and U-bolts, secure the mounting plates to the pipe applying enough torque such that the meter cannot be moved up or down (or side to side).

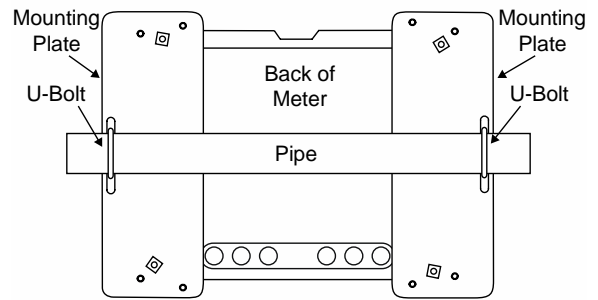
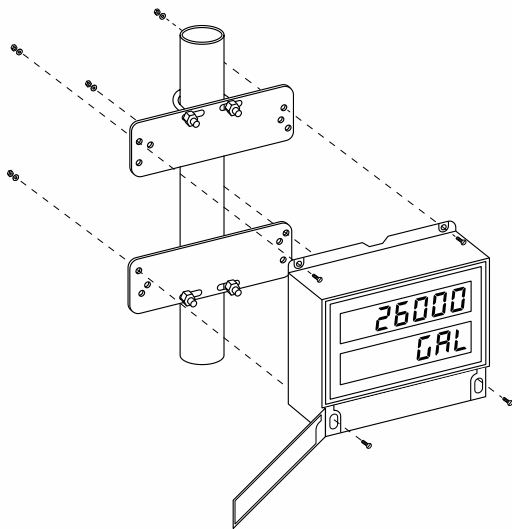
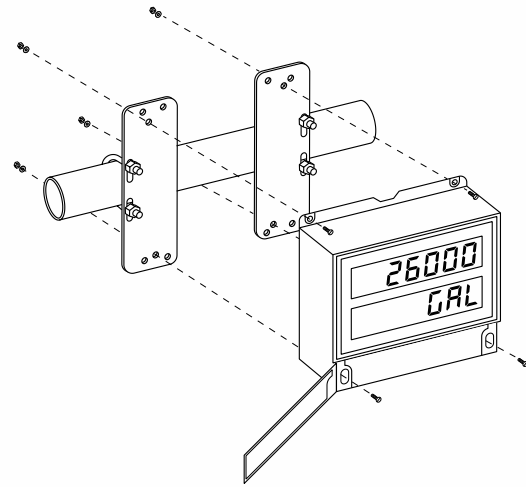

Figure 7. Horizontal Pipe Mount Assembly

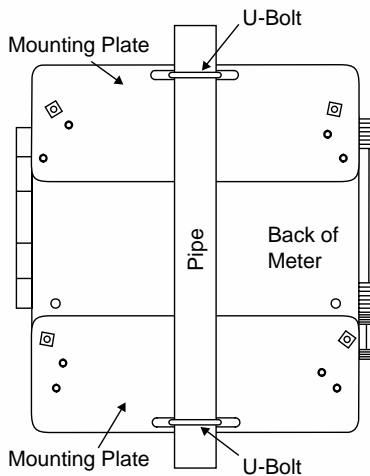

Figure 6. Vertical Pipe Mount Assembly



## Installation Overview

We recommend the following sequence for getting the meter into service:

1. **DO NOT** apply AC or DC power to the meter.
2. Connect the meter to the PC with the USB cable provided. **DO NOT** use a different USB cable.
3. If MeterView Pro (MVPro) is already installed in your computer, then the program will launch automatically in most systems. If the program does not start automatically, double-click on the MVPro icon.
4. If MVPro is not installed, follow the instructions provided below.
5. Use MVPro to configure the meter for your application.
6. Disconnect the USB cable from the meter.
7. Apply power and signal and check operation of the meter.
8. Install the meter and put into service.
9. Make any programming adjustments using the programming buttons.

## MeterView Pro Software

The easiest and quickest way to program your Helios meter is to use the FREE MeterView Pro programming software. This software is loaded into the meter and connects and installs directly to your PC with the USB cable provided. **DO NOT** use a different USB cable. We recommend that the first thing you do after taking the meter out of the box is connect the Helios to your PC with the provided USB cable. **DO NOT** apply AC or DC power to the meter while your PC is connected to the meter as it will disrupt the USB connection. It is not necessary to apply an input signal.

MeterView Pro programming software is intuitive, and most customers can get their meter programmed as they like without even looking in the manual.

Watch Meterview Pro Software Video at  
[www.prediq.com/meterviewpro](http://www.prediq.com/meterviewpro)

## MeterView Pro Installation

1. Connect one end of the provided USB cable to the meter and the other end to the computer. The computer will automatically install the driver software it needs to talk to the meter. Follow the on-screen instructions and allow sufficient time for the process to complete. This can take a few minutes. If the process is interrupted, then it could leave the system in an unstable condition.

### ⚠ WARNINGS

- Only one meter may be connected at a time. Attaching multiple meters will cause a conflict with the meter software.
- **DO NOT** apply AC or DC power to the meter when using the USB connection.

2. Once the driver is installed, an AutoPlay dialog should appear for the drive "MAINSTAL." Click "Open folder to view files."

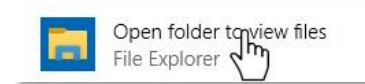

If the computer does not display an AutoPlay dialog for the drive "MAINSTAL," you should open My Computer and double-click on the drive labeled "MAINSTAL."

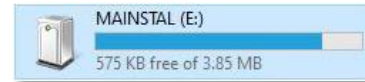

3. Double-click on the file named "MAStart." The program will open a few windows and install two programs on your computer. Simply follow the on-screen instructions until you see one of the dialogs below. If you receive a "User Account Control" warning, click "Yes."

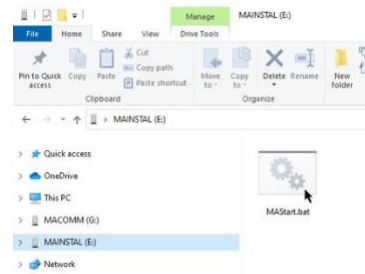

4. If there is an update available, click the "Update" button to install the new version. Otherwise, click "Configure" to begin programming your meter.

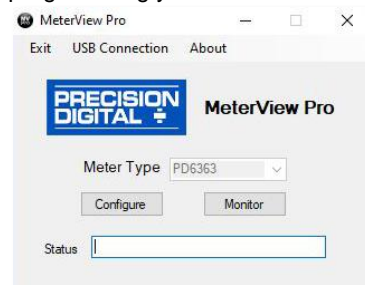

**Note:** If you decide to update your MeterView Pro software, once the installation has completed, you will be asked if you want to update the setup files located on the meter itself. This way, you will always have the most current version on the meter for future installs.

### ⚠ WARNING

- **DO NOT** unplug the meter while the new installation files are being written to it. The meter will display  $\overline{E}$  during the process and you will receive an on-screen notification once the process is complete.



## Transmitter Supply Voltage Selection (P+, P-)

All meters, including models equipped with the 12-24 VDC power option, are shipped from the factory configured to provide 24 VDC power for the transmitter or sensor.

If the transmitter requires 5 or 10 VDC excitation, the switch labeled P+/P- must be configured accordingly.

To access the voltage selection switch:

1. Turn off the power to the meter.
2. Unscrew and open the lower door panel.
3. Locate the P+/P- switch located in the center of the connections board (see diagram below).
4. Flip this switch into the appropriate position for the required transmitter excitation.

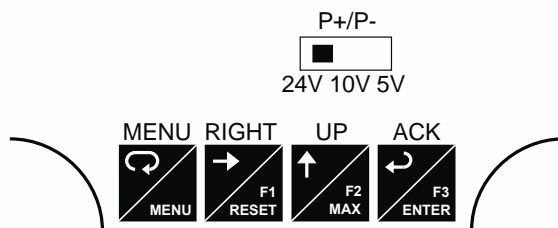

Figure 8. Transmitter Supply Voltage Selection

## Connections

All connections are made to screw terminal connectors located under the lower door panel. Remove the single securing screw in order to access the wiring terminals.

### CAUTION

- Use copper wire with 60°C or 60/75°C insulation for all line voltage connections. Observe all safety regulations. Electrical wiring should be performed in accordance with all applicable national, state, and local codes to prevent damage to the meter and ensure personnel safety.

## Connectors Labeling

The connectors' label, affixed to the inside of the lower door panel, shows the location of all connectors available with the ordered configuration.

### WARNINGS

- **DO NOT** connect any equipment to the RJ45 M-LINK connector. Otherwise damage will occur to the equipment and the meter.
- **DO NOT** disconnect the RJ45 connector located to the left of the power terminal block. Doing so will disable the on-board digital I/O, and the RS-485 serial communications.

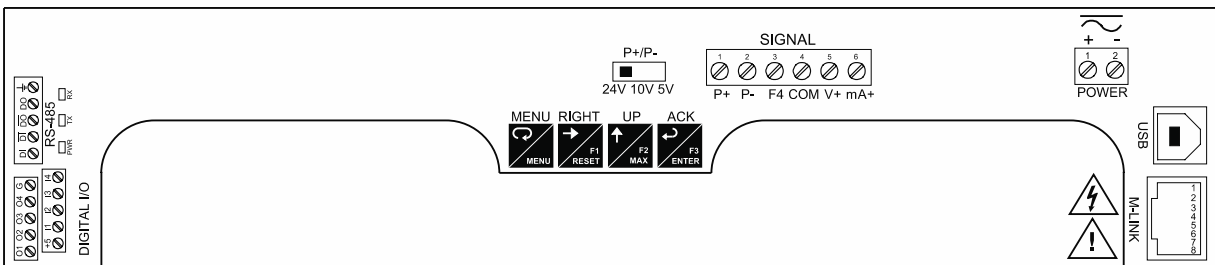

Figure 9. PD2-6000-6H0 / 7H0 Connectors Label

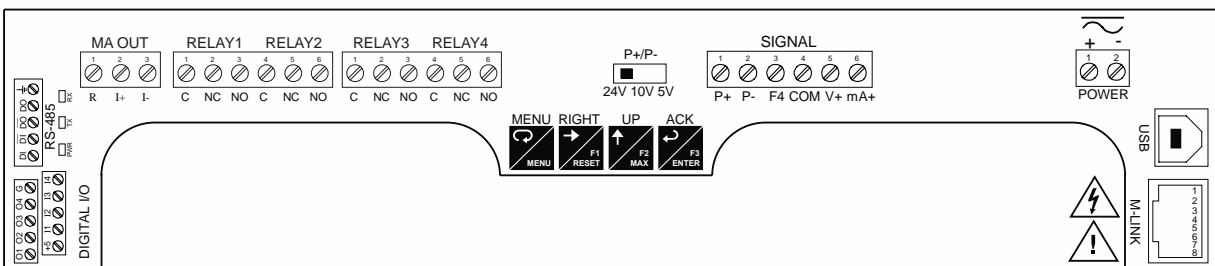
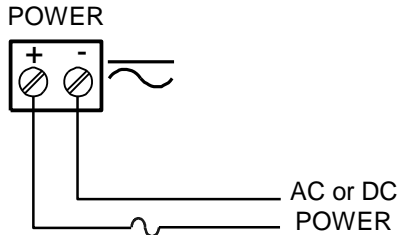

Figure 10. PD2-6000-6H7 / 7H7 Connectors Label

### Power Connections

Power connections are made to a two-terminal connector labeled POWER. The meter will operate regardless of DC polarity connection. The + and - symbols are only a suggested wiring convention. There are separate models for low voltage and high voltage power. See *Ordering Information* on page 6 for details.



Required External Fuse:  
5 A max, 250 V Slow Blow

Figure 11. Power Connections

### Signal Connections

Signal connections are made to a six-terminal connector labeled SIGNAL. The COM (common) terminal is the return for the 4-20 mA and the ±10 V input signals.

### Current (mA) Connections

The following figures show examples of current connections.

There are no switches or jumpers to set up for current inputs. Setup and programming is performed through the programming buttons or MeterView Pro software.

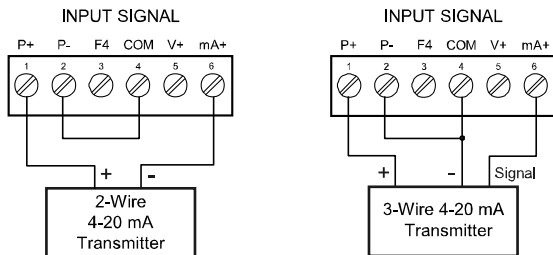

Figure 12. Transmitters Powered by Internal Supply

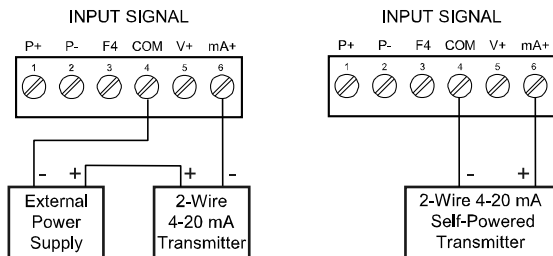

Figure 13. Transmitter Powered by External Supply or Self-Powered

The current input is protected against current overload by an internal resettable fuse. The display may or may not show a fault condition depending on the nature of the overload.

The fuse limits the current to a safe level when it detects a fault condition, and automatically resets itself when the fault condition is removed.

### Voltage (V) Connections

The following figures show examples of voltage connections.

There are no switches or jumpers to set up for voltage inputs. Setup and programming is performed through the programming buttons or MeterView Pro software.

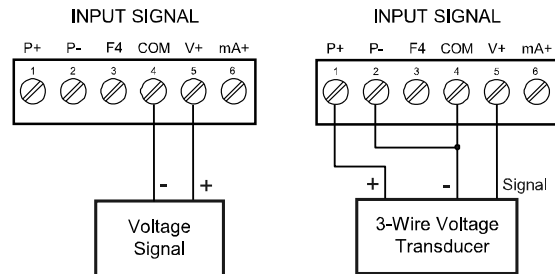

Figure 14. Voltage Input Connections

The meter is capable of accepting any voltage from -10 VDC to +10 VDC.

### Relay Connections

Relay connections are made to two six-terminal connectors labeled RELAY1 – RELAY4. Each relay's C terminal is common only to the normally open (NO) and normally closed (NC) contacts of the corresponding relay. The relays' C terminals should not be confused with the COM (common) terminal of the INPUT SIGNAL connector.

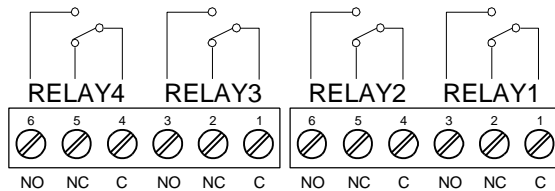

Figure 15. Relay Connections

### Switching Inductive Loads

The use of snubbers to suppress electrical noise is strongly recommended when switching inductive loads to prevent disrupting the microprocessor's operation. The snubbers also prolong the life of the relay contacts. Suppression can be obtained with resistor-capacitor (RC) networks assembled by the user or purchased as complete assemblies. Refer to the following circuits for RC network assembly and installation:

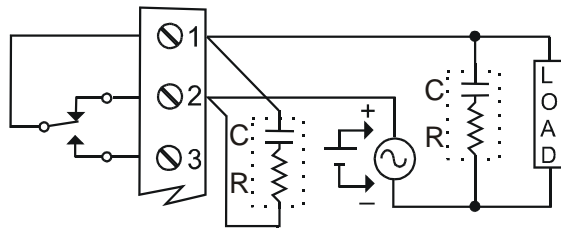

Figure 16. AC and DC Loads Protection

Choose R and C as follows:

R: 0.5 to 1  $\Omega$  for each volt across the contacts

C: 0.5 to 1  $\mu\text{F}$  for each amp through closed contacts

**Notes:**

1. Use capacitors rated for 250 VAC.
2. RC networks may affect load release time of solenoid loads. Check to confirm proper operation.
3. Install the RC network at the meter's relay screw terminals. An RC network may also be installed across the load. Experiment for best results.

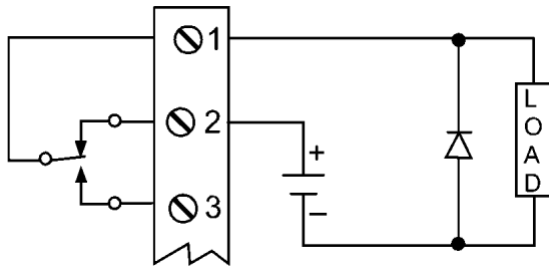

Use a diode with a reverse breakdown voltage two to three times the circuit voltage and forward current at least as large as the load current.

Figure 17. Low Voltage DC Loads Protection

### RC Networks (Snubbers) Available from Precision Digital

RC networks are available from Precision Digital and should be applied to each relay contact switching an inductive load. Part number: [PDX6901](#).

*Note: Relays are de-rated to 1/14th HP (50 watts) with an inductive load.*

### RS-485 Connections

The RS-485 connections are made to a five terminal connector used for Modbus® RTU serial communications. The RS-485 terminals include Transmit Data (DO) and (/DO), Receive Data (DI) and (/DI), and Signal Ground. See *Modbus RTU Serial Communications (5E r iRL)* on page 42 for more information.

There are three diagnostic LEDs: Power (PWR) Transmit Data (TX), and Receive Data (RX) to show when the meter is transmitting and receiving data from other devices.

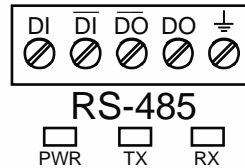

Figure 18. RS-485 Connection

### RS-485 Multi-Drop Connection

When using more than one meter in a multi-drop mode, each meter must be provided with its own unique address. The meter address (Slave ID) can be programmed between 1 and 247. The transmit delay can be set between 0 and 199 ms. The parity can be set to even, odd, or none with 1 or 2 stop bits.

**To change the meter address:**

1. Press and hold the Menu button for three seconds to access Advanced Features menu of the meter.
2. Press Up arrow until Serial (5E r iRL) menu is displayed and press Enter, Addr EE5 is displayed.
3. Press Enter to change meter address using Right and Up arrow buttons. Press Enter to accept.
4. Press Menu button to exit and return to Run Mode.

### RS-485 Serial Converters

To convert the RS-485 to RS-232, use the PDA7485-I converter. To convert the RS-485 to USB, use the PDA8485-I converter. See *Ordering Information* on page 6 for additional information.

**RS-485 Connection Examples**

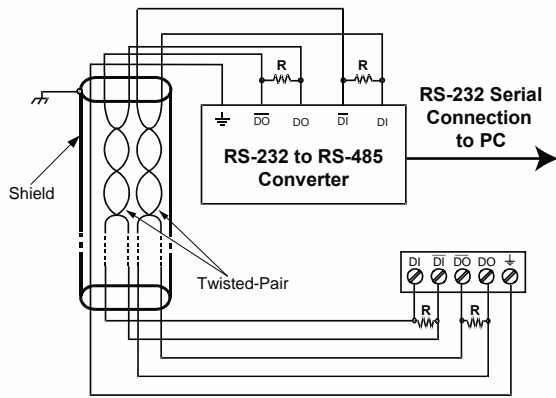

**Figure 19. Five-Wire RS-485 Connections**

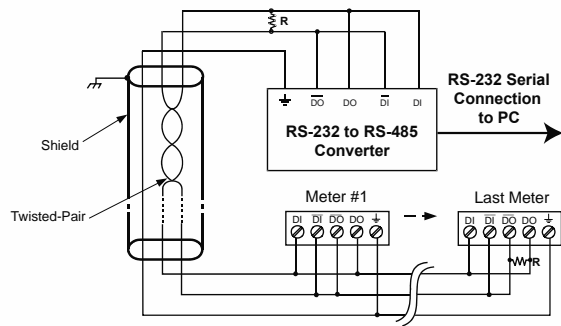

**Figure 20. Three-Wire RS-485 Multi-Drop Connections**

**Notes:**

1. Termination resistors are optional, and values depend on the cable length and characteristic impedance. Consult the cable manufacturer for recommendations.
2. Refer to RS-232 to RS-485 Converter documentation for further details.
3. Use shielded cable, twisted-pair plus ground. Connect ground shield only at one location

**RS-485 Converter Connections**

Figure 21 below details the wiring connections from the RS-485 connector to an RS-485 serial converter (such as the PDA7485-I or PDA8485-I) for a five-wire network.

RS-485 Connector to RS-485 Serial Converter Connections	
RS-485 Connector	RS-485 to USB or RS-232 Converter
$\overline{\text{DI}}$	$\overline{\text{DI}}$
DO	DI
$\overline{\text{DI}}$	$\overline{\text{DO}}$
DI	DO

**Figure 21. Connections for RS-485 Connector to Serial Converter**

**Three-Wire Connection**

In order to wire the five pins for use as a three-wire half-duplex RS-485 connection, it is necessary to create a jumper connection between DI to DO and /DI to /DO- as shown below.

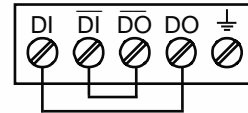

**Figure 22. Three-Wire RS-485 Connection**

**Digital I/O Connections**

Digital inputs and outputs are provided in order to expand the functionality of the meter. Digital input connections are made via a push button or switch to the appropriate digital input terminal and the +5 VDC terminal. Digital output connections are made by wiring from the appropriate digital output terminal to the ground terminal.

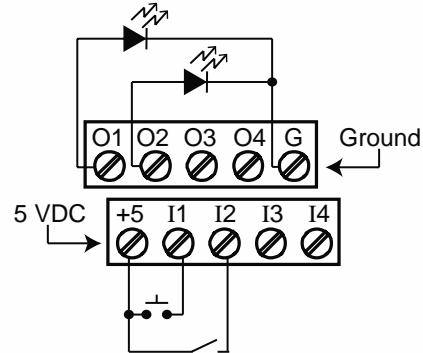

**Figure 23. Digital Input and Output Connections**

### F4 Digital Input Connections

A digital input, F4, is standard on the meter. This digital input should be connected with a normally open contact across F4 and COM, or with an active low signal applied to F4. It can be used for remote operation of front-panel buttons, to acknowledge/reset relays, or to reset max/min values. See *Function Keys & Digital I/O Available Settings* on page 45 for a complete list of capabilities.

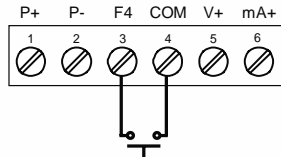

Figure 24. F4 Digital Input Connections

### 4-20 mA Output Connections

Connections for the 4-20 mA transmitter output are made to the connector terminals labeled mA OUT. The 4-20 mA output may be powered internally or from an external power supply.

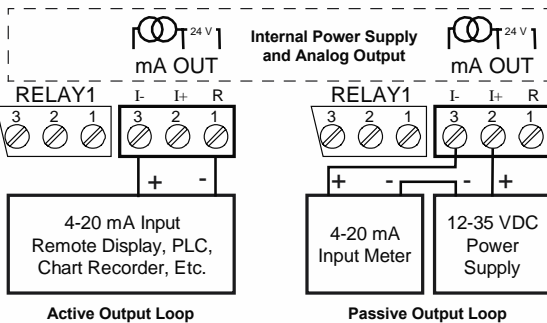

Figure 25. 4-20 mA Output Connections

### Analog Output Power Supply

The internal 24 VDC power supply powering the analog output may be used to power other devices, if the analog output is not used. The I+ terminal is the +24 V and the R terminal is the return.

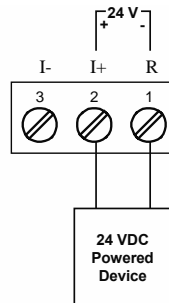

Figure 26. Analog Output Supply Powering Other Devices

### Remote Operation of Meter

The meter can be operated via the programming buttons or a PDA2364-MRUE remote control station using the digital inputs and outputs connections as illustrated in *Figure 27. Meter to PDA2364-MRUE Control Station Connection*.

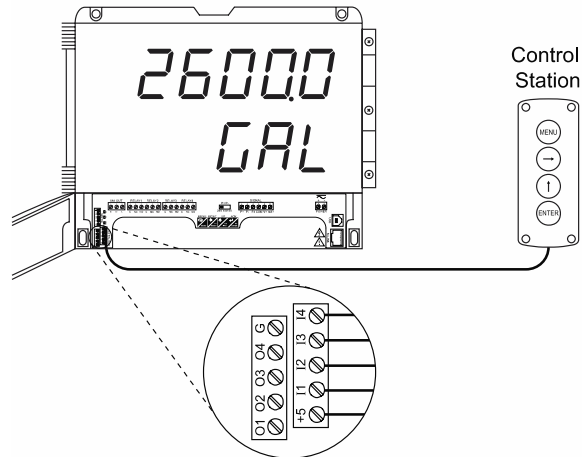

Figure 27. Meter to PDA2364-MRUE Control Station Connection

### Interlock Relay Feature

As the name implies, the interlock relay feature reassigns one, or more, alarm/control relays for use as interlock relay(s). Interlock contact(s) are wired to digital input(s) and activate the interlock relay. This feature is enabled by configuring the relay, and the corresponding digital input(s), see *Setting Up the Interlock Relay (Force On) Feature* on page 38.

In the example below, an Interlock Contact switch is connected to a digital input, which will be used to force on (energize) the Interlock Relay. The Interlock Relay and the Control Relay are connected in series with the load.

- When the Interlock Contact is closed (safe), the Interlock Relay energizes, allowing power to flow to the Control Relay; the corresponding front panel LED is on.
- When the Interlock Contact is open, the corresponding front panel LED flashes (locked out), the Interlock Relay is de-energized, preventing power from flowing to the Control Relay and the load.

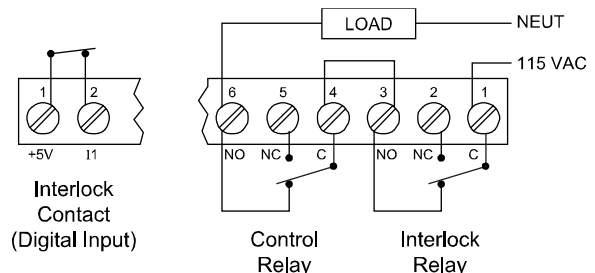

Figure 28. Interlock Connections

## Setup and Programming

There is **no need to recalibrate** the meter when first received from the factory. The meter is **factory calibrated** prior to shipment for milliamps and volts with calibration equipment that is certified to NIST standards.

### Overview

There are no jumpers to set for the meter input selection.

Setup and programming is done using MeterView Pro or through the programming buttons.

After power and input signal connections have been completed and verified, apply power to the meter.

### LED Status Indicators

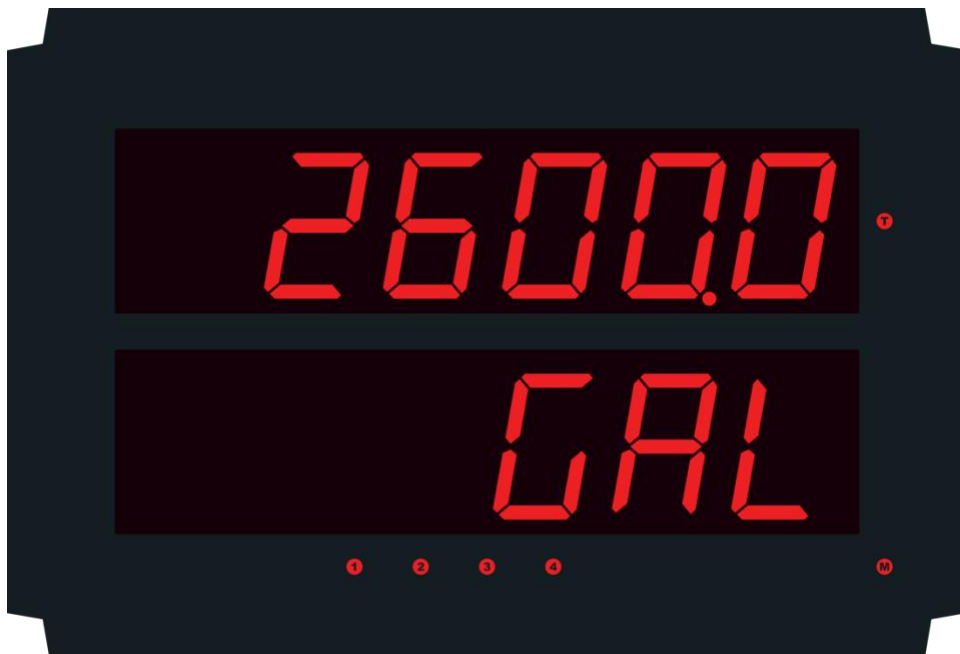

LED	State	Indication
1-4	Steady	Alarm condition based on set and reset points, independent of relay status in certain configurations. (Available on all meter configurations, including those without relays installed)
1-4	Flashing	Relay interlock switch open
1-4 & M	Flashing	Relay in manual control mode
T	Flashing	Meter in Tare mode
M	Flashing	Analog output in manual control mode



## Programming Buttons

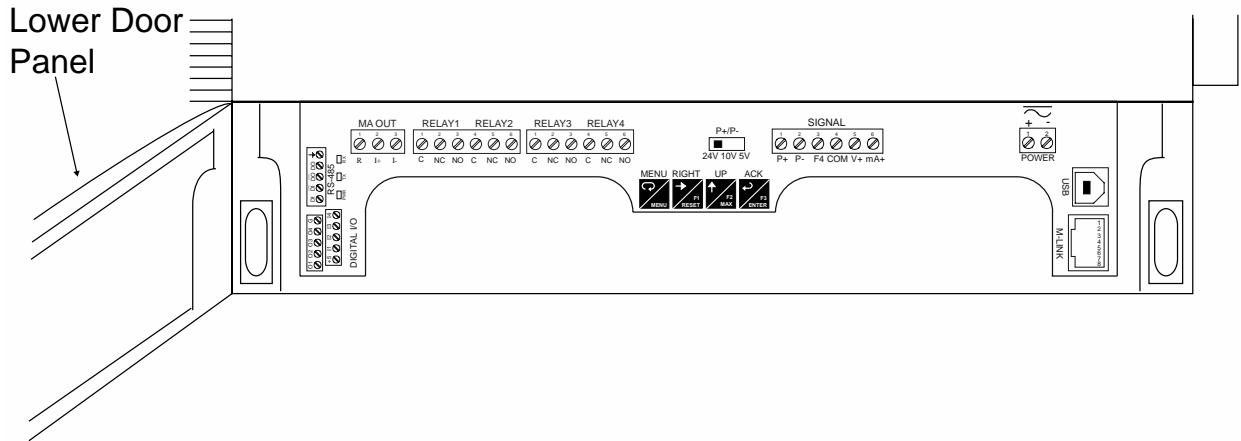

Button	Description
	Menu
	Right Arrow/F1

Button	Description
	Up Arrow/F2
	Acknowledge (Enter)/F3

- Press the Menu button to enter or exit the Programming Mode at any time.
- Press the Right arrow button to move to the next digit during digit or decimal point programming.
- Press or hold the Up arrow button to scroll through the menus, decimal point, or to increment the value of a digit.
- Press the Enter button to access a menu or to accept a setting.
- Press and hold the Menu button for three seconds to access the advanced features of the meter.



### Remote Buttons

The meter can be operated via a remote control station (PDA2364-MRUE) using the digital input connections. The PDA2364-MRUE mimics the Helios's four programming buttons: Menu, Right Arrow, Up Arrow, and Enter.

See *Remote Operation of Meter* on page 21 for details.

## Display Functions & Messages

The meter displays various functions and messages during setup, programming, and operation. The following table shows the main menu functions and messages in the order they appear in the menu.

Display Functions & Messages		
Display	Parameter	Action/Setting Description
SEtUP	Setup	Enter Setup menu
INP	Input	Enter Input selection menu
mA	4-20 mA	Set meter for 4-20 mA input
VDC	0-10 VDC	Set meter for ±10 VDC input
d-SCL	Dual-scale	Press Enter to select dual-scale display for some level applications (Select Yes or No)
UNITS	Units	Select the display units/tags
dEc Pt	Decimal point	Set decimal point
PV 1	PV1	PV1 decimal point (Level)
PV 2	PV2	PV2 decimal point (Level)
PrOG	Program	Enter the Program menu
SCALE	Scale	Enter the Scale menu
SCALE 1	Scale 1	Enter the Scale menu for PV1
SCALE 2	Scale 2	Enter the Scale menu for PV2
CLIB	Calibrate	Enter the Calibration menu
INP 1	Input 1	Calibrate input 1 signal or program input 1 value
DIS 1	Display 1	Program display 1 value
INP 2	Input 2	Calibrate input 2 signal or program input 2 value (up to 32 points)
DIS 2	Display 2	Program display 2 value (up to 32 points)
Error	Error	Error, calibration not successful, check signal or programmed value
dSPLY	Display	Enter the Display menu
LINE 1	Display Line 1	Press Enter to assign the Main display parameter (default: PV)
LINE 2	Display Line 2	Press Enter to assign the small display parameter (default: engineering units)
d-INtY	Display intensity	Set display intensity level from 1 to 8
RELAY	Relay	Enter the Relay menu
REL 1	Relay 1	Relay 1 setup
ACT 1	Action 1	Set relay 1 action

Display Functions & Messages		
Display	Parameter	Action/Setting Description
Auto	Automatic	Set relay for automatic reset
Auto-manual	Auto-manual	Set relay for automatic & manual reset any time
LATCH	Latching	Set relay for latching operation
Latch-cleared	Latching-cleared	Set relay for latching operation with manual reset only after alarm condition has cleared
ALTErn	Alternate	Set relay for pump alternation control
SAMPL	Sampling	Set relay for sampling operation
OFF	Off	Disable relay and front panel status LED (Select Off to enable Interlock feature)
SET 1	Set 1	Program set point 1
RES 1	Reset 1	Program reset point 1
REL 2	Relay 2	Relays 2-4 setup
FRSAFE	Fail-safe	Enter Fail-safe menu
FLS 1	Fail-safe 1	Set relay 1 fail-safe operation
ON	On	Enable fail-safe operation
OFF	Off	Disable fail-safe operation
FLS 2	Fail-safe 2	Set relays 2-4 fail-safe operation
DELAY	Delay	Enter relay Time Delay menu
DEL 1	Delay 1	Enter relay 1 time delay setup
ON 1	On 1	Set relay 1 On time delay
OFF 1	Off 1	Set relay 1 Off time delay
DEL 2	Delay 2	Enter relays 2-4 time delay setup
brERR	Loop break	Set relay condition if loop break detected
IGNorE	Ignore	Ignore loop break condition (Processed as a low signal condition)
ON	On	Relay goes to alarm condition when loop break is detected
OFF	Off	Relay goes to non-alarm condition when loop break is detected
ROut	Analog output	Enter the Analog output scaling menu
DIS 1	Display 1	Program display 1 value
OUT 1	Output 1	Program output 1 value (e.g. 4.000 mA)

Display Functions & Messages		
Display	Parameter	Action/Setting Description
dis 2	Display 2	Program display 2 value
Out 2	Output 2	Program output 2 value (e.g. 20.000 mA)
rESEt	Reset	Press Enter to access the Reset menu
rSt H i	Reset high	Press Enter to reset max display
rSt Lo	Reset low	Press Enter to reset min display
rSt HL	Reset high & low	Press Enter to reset max & min displays
rSt tr	Reset tare	Reset tare
Control	Control	Enter Manual Control menu
Auto	Automatic	Press Enter to set meter for automatic operation
MAN	Manual	Press Enter to manually control relays or analog output operation
PR55	Password	Enter the Password menu
PR55 1	Password 1	Set or enter Password 1
PR55 2	Password 2	Set or enter Password 2
PR55 3	Password 3	Set or enter Password 3
unLoc	Unlocked	Program password to lock meter
Locd	Locked	Enter password to unlock meter
999999 -999999	Flashing	Over/under range condition

## Main Menu

The main menu consists of the most commonly used functions: *Setup*, *Reset*, *Control*, and *Password*.

- Press Menu button to enter Programming Mode then press the Up arrow button to scroll main menu.
- Press Menu, at any time, to exit and return to Run Mode. Changes made to settings prior to pressing Enter are not saved.
- Changes to the settings are saved to memory only after pressing Enter/F3.
- The display moves to the next menu every time a setting is accepted by pressing Enter/F3.

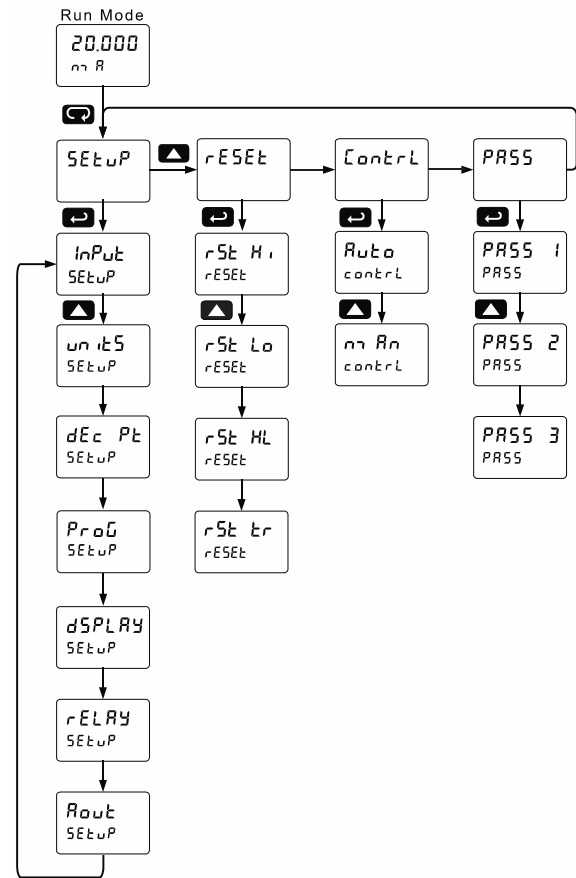

### Setting Numeric Values

The numeric values are set using the Right and Up arrow buttons. Press Right arrow to select next digit and Up arrow to increment digit value. The digit being changed is displayed brighter than the rest.

Press and hold Up to auto-increment the display value. If negative numbers are allowed, the first digit position will include a negative symbol (-) after the 9. Press the Enter button, at any time, to accept a setting or Menu button to exit without saving changes.

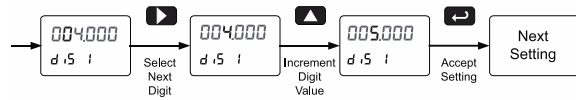

### Setting Up the Meter (SEtUP)

The Setup menu is used to select:

1. Input signal the meter will accept
2. Dual-scale feature for some level applications
3. Select the display units/tags
4. Decimal point position
5. Programming Menu
6. Display parameter and intensity
7. Relay operation
8. 4-20 mA analog output scaling

Press the Enter button to access any menu or press Up arrow button to scroll through choices. Press the Menu button to exit at any time.

### Setting the Input Signal (InPUt)

Enter the Input menu to set up the meter to display current (mA) or voltage (VOLT) inputs.

The current input is capable of accepting any signal from 0 to 20 mA. Select current input to accept 0-20 mA or 4-20 mA signals.

The voltage input is capable of accepting any signal from -10 to +10 VDC. Select voltage input to accept 0-5, 1-5, 0-10, or ±10 VDC signals.

After selecting mA or Volt input, d-SCALE is displayed; press Enter to select "Yes" or "No". Selecting "Yes" enables the dual-scale feature, which allows for the Scale (SCALE) and Units (UNITS) menus to be used to scale the same input in two different scales for PV1 & PV2.

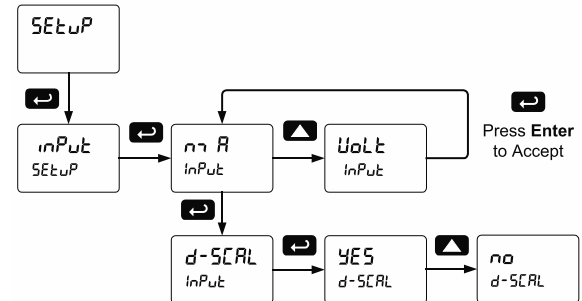

Set d-SCALE to no if only one scale is needed for the input.

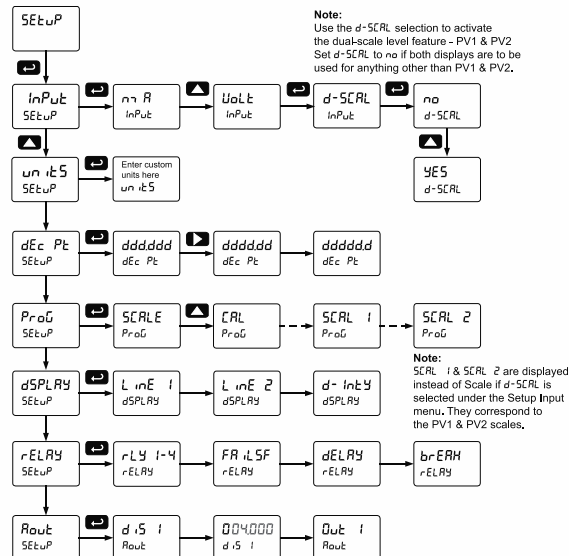

### Setting the Display Units or Custom Tags (dPU dT)

Enter the display unit or custom tag that will be displayed if dPU is selected as the line 2 parameter. See the *Setting the Display Parameter & Intensity (dSP dI)* flow chart on page 30 to access the display menu to show the unit or tag on display line 2. The engineering units or custom legends can be set using the following 7-segment character set:

Display	Character	Display	Character
0	0	K	K
1	1	L	L
2	2	m	m
3	3	n	n
4	4	O	O
5	5	o	o
6	6	P	P
7	7	q	q
8	8	r	r
9	9	S	S
A	A	t	t
b	b	u	u
C	C	v	v
c	c	w	w
d	d	X	X
E	E	Y	Y
F	F	Z	Z
G	G	.	.
g	g	/	/
H	H	]	]
h	h	[	[
i	i	=	=
J	J	°	Degree(<)
			Space

Notes:

1. Degree symbol represented by (<) if programming with MeterView Pro.
2. The letters "m" and "w" use two 7-segment LEDs each; when selected the characters to the right are shifted one position.
3. Press and hold up arrow to auto-scroll the characters in the display.

### Setting the Decimal Point (dEc Pt)

The decimal point may be set with up to five decimal places or with no decimal point at all. The decimal point selection should be made prior to scaling, calibrating or programming the meter. Pressing the Right arrow moves the decimal point one place to the right until no decimal point is displayed, and then it moves to the leftmost position. Pressing the Up arrow moves the decimal point one place to the left. If the dual-scale level feature is selected, the decimal point selections for PV1 & PV2 are enabled.

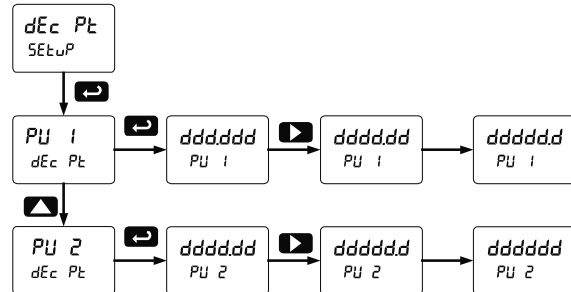

### Programming the Meter (Prog)

The meter may either be scaled (SCALE) without applying an input or calibrated (CAL) by applying an input. The meter comes factory calibrated to NIST standards, so for initial setup, it is recommended to use the (SCALE) function.

The Program menu contains the Scale (SCALE) and the Calibrate (CAL) menus.

Process inputs may be scaled or calibrated to any display within the range of the meter.

The PD2-6000 is a single input meter with dual-scale capability.

If the dual-scale level feature is selected in the Setup menu, the Scale 1 and Scale 2 menus are enabled for PV1 & PV2 respectively.

The process input may be calibrated or scaled to any display value within the range of the meter.

*Note: The Scale and Calibrate functions are exclusive of each other. The meter uses the last function programmed. Only one of these methods can be employed at a time. The Scale and Calibrate functions can use up to 32 points (default is 2). The number of points should be set in the Advanced menu prior to scaling and calibration of the meter. See Multi-Point Linearization (LINEAR) menu on page 43 for details.*

#### Program Menu for Single Scale Process

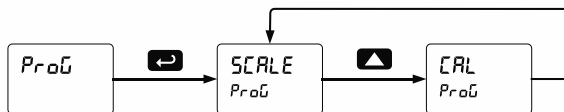

#### Program Menu for Dual-Scale Level Applications

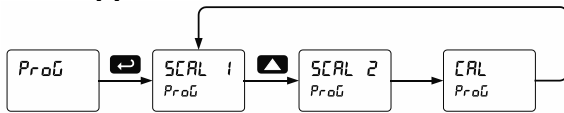

Additional parameters, not needed for most applications, are programmed in the Advanced Features menu. See Advanced Features Menu on page 41.

#### Multi-Point Calibration & Scaling

The meter is set up at the factory for 2-point linear calibration. The number of points for multi-point calibration/scaling is set up in the Advanced Features menu. Up to 32 linearization points may be selected for PV1 and up to 8 linearization points may be selected for PV2. See Multi-Point Linearization (LINEAR) menu on page 43 for details.

### Scaling the Meter (SCALE)

The process input (4-20 mA, ±10 VDC) can be scaled to display the process variable in engineering units.

A signal source is not needed to scale the meter; simply program the inputs and corresponding display values.

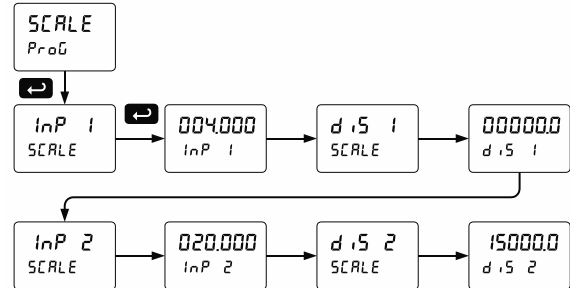

### Dual-Scale for Level Applications

The analog input can be displayed in two different scales, by enabling the dual-scale feature (d-SCALE) in the Setup - Input menu. See Setting the Input Signal (INPUT) on page 26.

To enable the dual-scale feature for some level applications you must select d-SCALE in the Input selection menu.

#### Scaling the Input for PV1 (SCALE 1)

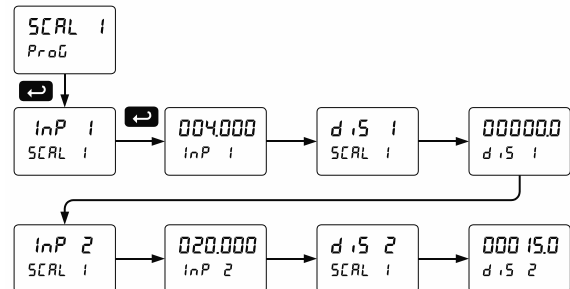

#### Scaling the Input for PV2 (SCALE 2)

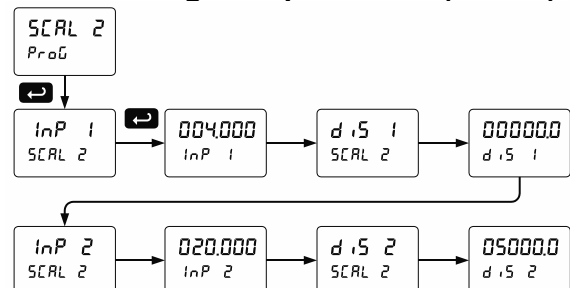

### Error Message (Error)

An error message indicates that the calibration or scaling process was not successful.

After the error message is displayed, the meter reverts to the input prior to the failure during calibration or scaling and to input 1 during internal calibration, allowing the appropriate input signal to be applied or programmed.

The error message might be caused by any of the following conditions:

1. Input signal is not connected to the proper terminals or it is connected backwards\*.
2. Wrong signal selection in *Setup* menu\*.
3. Minimum input span requirements not maintained.
4. Input 1 signal inadvertently applied to calibrate input 2\*.

\*Not relevant when scaling the meter.

For instructions on how to program numeric values see *Setting Numeric Values*, page 26.

### Minimum Input Span

The minimum input span is the minimum difference between input 1 and input 2 signals required to complete the calibration or scaling of the meter.

Input Range	Input 1 & Input 2 Span
4-20 mA	0.15 mA
±10 VDC	0.10 VDC

### Calibrating the Meter with External Source (CAL)

Note: To scale the meter without a signal source refer to *Scaling the Meter (SCALE)* on page 28.

The meter can be calibrated to display the process variable in engineering units by applying the appropriate input signal and following the calibration procedure.

The use of a calibrated signal source is strongly recommended to calibrate the meter.

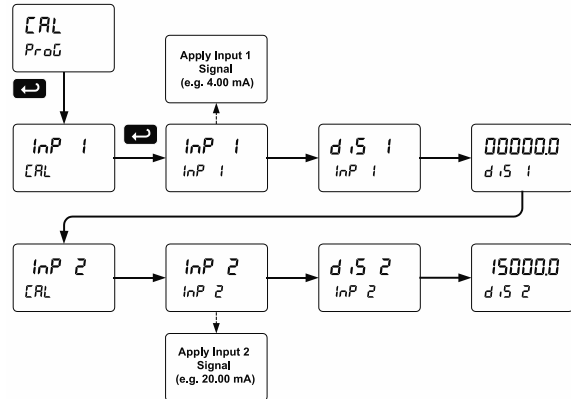

Note: Inputs for the above example are:  
 Input 1: 4.00 mA; Display 1: 0.0 Gallons  
 Input 2: 20.00 mA; Display 2: 15000.0 Gallons

Warm up the meter for at least 15 minutes before performing calibration to ensure specified accuracy.



### Setting the Display Parameter & Intensity (dSPLeRY)

The main display (LInE 1) can be programmed to display:

1. Process value 1 (PV1)
2. Process value 2 (PV2)\*
3. Percent of PV1 (PCT)\*
4. Relay set points
5. Max & min values
6. Modbus input
7. Display reading and units
8. Display gross
9. Toggle net & gross

The secondary display (LInE 2) can be programmed to display:

1. Unit
2. Process value 1 (PV1)
3. Process value 2 (PV2)\*
4. Percent of PV1 (PCT)\*
5. Relay set points
6. Max & min values
7. Engineering units or custom legends
8. Modbus input
9. Off (no display)
10. Toggle reading and units
11. Display gross
12. Toggle net/gross

\*These menu items will only appear if Dual-Scale feature is turned on.

After setting up the input and display, press the Menu button to exit programming and skip the rest of the setup menu.

### Display Parameter Menu

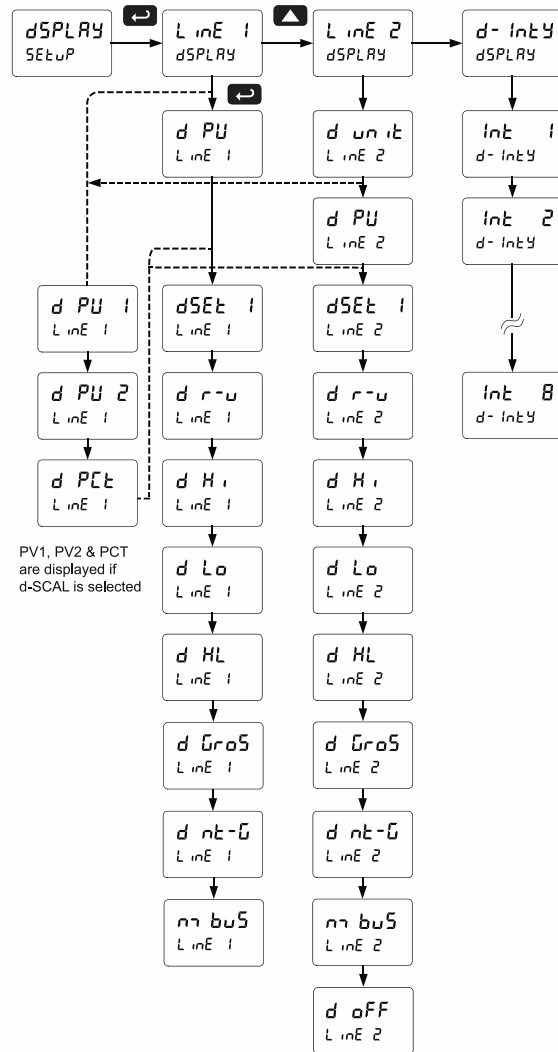

### Display Intensity (d- IntY)

The meter has eight display intensity levels to give the best performance under various lighting conditions. Select intensity 8 for outdoor applications. The default intensity is 6.

### Display Toggling Between Reading & Units with Tag

The PD2-6000 can be programmed so that line 1 toggles between the reading and units and line 2 displays a tag. For instance, line 1 toggles between 9500 and Gal and line 2 displays Tank 1.



### Dual-Scale Display Feature

The dual-scale feature is of particular value in level applications where a second scaled display can represent the measured input in a different form (i.e. gallons & height). Both displays are independently scaled and are based on the 4-20 mA input signal.

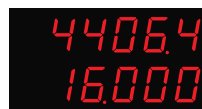

Gallons & mA



Gallons & Height

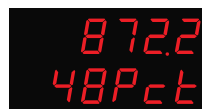

Gallons & Percent

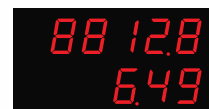

Gallons & Head PSI

## Setting the Relay Operation (rELAY)

This menu is used to set up the operation of the relays.

**CAUTION**

- During setup, the relays do not follow the input and they will remain in the state found prior to entering the Relay menu.

1. Relay action
  - a. Automatic reset only (non-latching)
  - b. Automatic + manual reset at any time (non-latching)
  - c. Latching (manual reset only)
  - d. Latching with Clear (manual reset only after alarm condition has cleared)
  - e. Pump alternation control (automatic reset only)
  - f. Sampling (the relay is activated for a user-specified time)
  - g. Off (relay state controlled by Interlock feature)
2. Set point
3. Reset point
4. Fail-safe operation
  - a. On (enabled)
  - b. Off (disabled)
5. Time delay
  - a. On delay (0-999.9 seconds)
  - b. Off delay (0-999.9 seconds)
6. Relay action for loss (break) of 4-20 mA input (ignore, on, off)

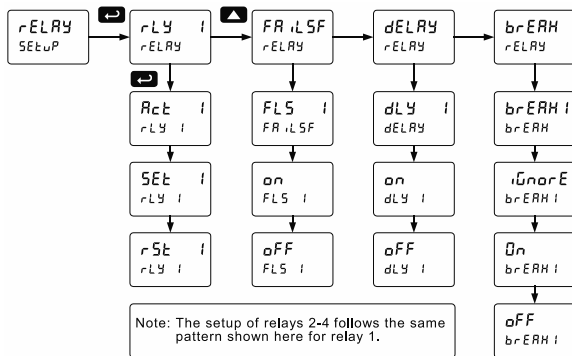

## Setting the Relay Action

Operation of the relays is programmed in the *Action* menu. The relays may be set up for any of the following modes of operation:

1. Automatic reset (non-latching)
2. Automatic + manual reset at any time (non-latching)
3. Latching (manual reset only, at any time)
4. Latching with Clear (manual reset only after alarm condition has cleared)
5. Pump alternation control (automatic reset only)
6. Sampling (the relay is activated for a user-specified time)
7. Off (relay state controlled by Interlock feature)

The following graphic shows relay 1 action setup; relay 2-4 are set up in a similar fashion.

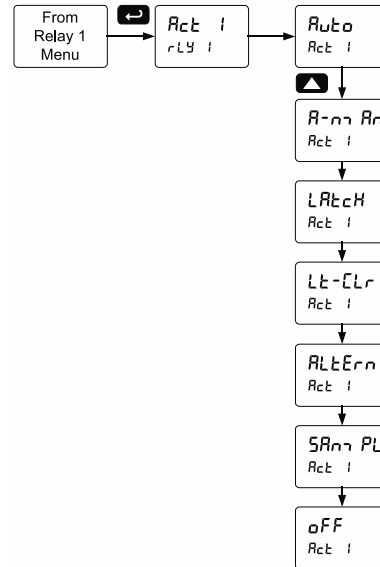

### Programming Set and Reset Points

High alarm indication: program set point above reset point.

Low alarm indication: program set point below reset point.

The deadband is determined by the difference between set and reset points. Minimum deadband is one display count. If the set and reset points are programmed with the same value, the relay will reset one count below the set point.

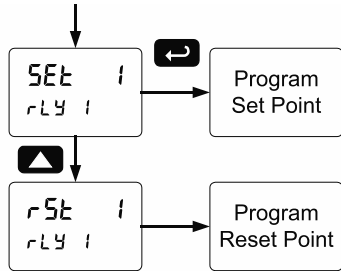

*Note: Changes are not saved until the reset point has been accepted.*

### Setting Fail-Safe Operation

In fail-safe mode of operation, the relay coil is energized when the process variable is within safe limits and the relay coil is de-energized when the alarm condition exists. The fail-safe operation is set independently for each relay. Select **on** to enable or select **off** to disable fail-safe operation.

### Programming Time Delay

The *On* and *Off* time delays may be programmed for each relay between 0 and 999.9 seconds. The relays will transfer only after the condition has been maintained for the corresponding time delay.

The *On* time delay is associated with the set point.

The *Off* time delay is associated with the reset point.

### Relay Action for Loss of 4-20 mA Input (Loop Break)

A loop break condition is triggered when the 4-20 mA input signal drops below 0.005 mA. Each relay may be programmed to go to one of the following conditions when the meter detects the loss of the input signal (i.e. < 0.005 mA):

1. Turn *On* (Go to alarm condition)
2. Turn *Off* (Go to non-alarm condition)
3. Ignore (Processed as a low signal condition)

The following graph shows the loop break relay operation for a high alarm relay.

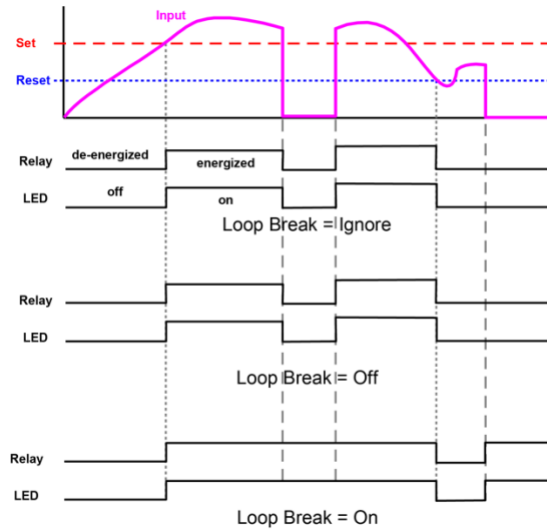

### Relay and Alarm Operation Diagrams

The following graphs illustrate the operation of the relays, status LEDs, and ACK button.

#### High Alarm Operation (Set > Reset)

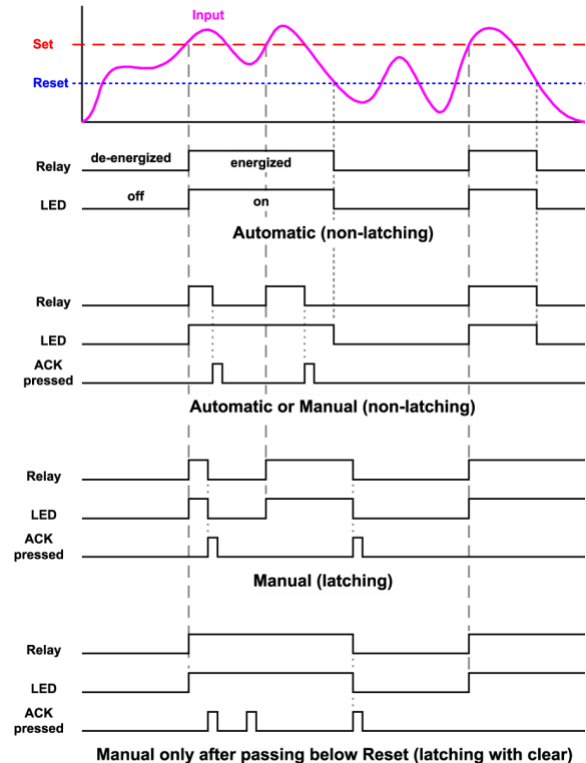

For Manual reset mode, ACK can be pressed anytime to turn "off" relay. To detect a new alarm condition, the signal must go below the set point, and then go above it.

### Low Alarm Operation (Set < Reset)

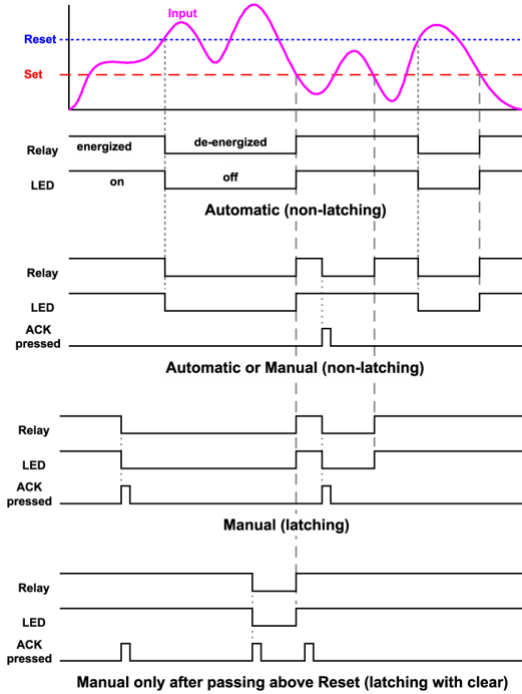

For Manual reset mode, ACK can be pressed anytime to turn "off" relay. For relay to turn back "on", signal must go above set point and then go below it.

### Low Alarm with Fail-Safe Operation (Set < Reset)

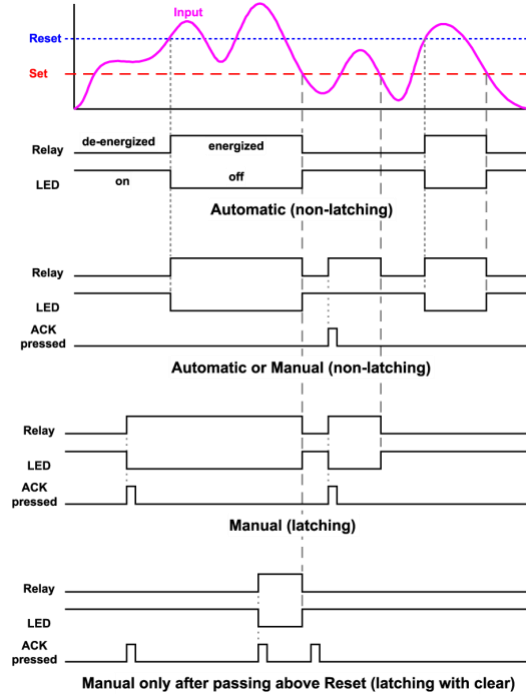

Note: Relay coil is energized in non-alarm condition. In case of power failure, relay will go to alarm state.

### High Alarm with Fail-Safe Operation (Set > Reset)

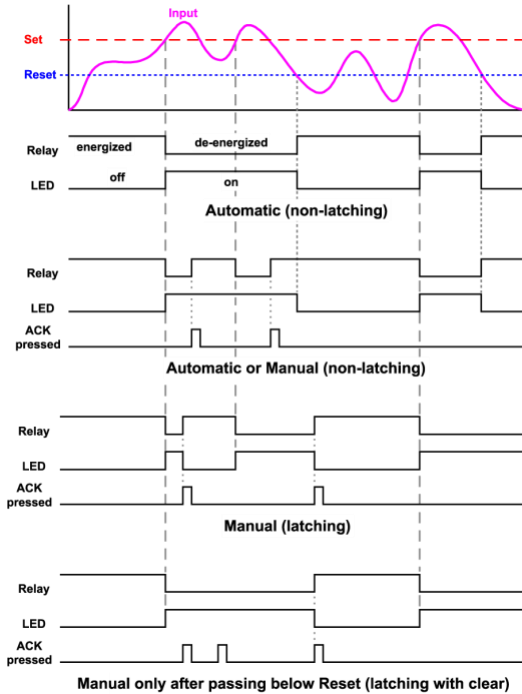

Note: Relay coil is energized in non-alarm condition. In case of power failure, relay will go to alarm state.

### Time Delay Operation

The following graphs show the operation of the time delay function.

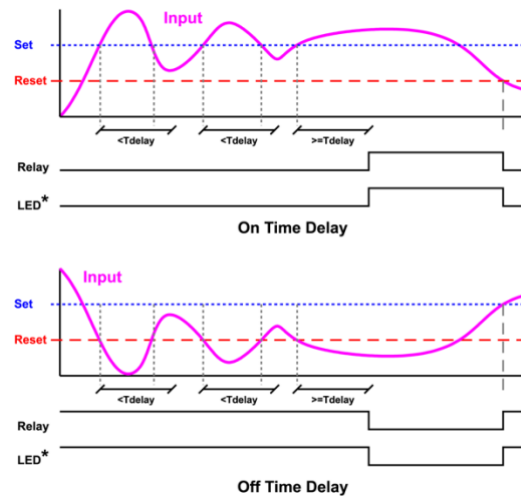

When the signal crosses the set point, the On time delay timer starts and the relay trips when the time delay has elapsed. If the signal drops below the set point (high alarm) before the time delay has elapsed, the On time delay timer resets and the relay does not change state. The same principle applies to the Off time delay.

Note: If "Automatic or Manual (R-nRn)" reset mode is selected, the LED follows the reset point and not the relay state when the relay is acknowledged.

### Pump Alternation Control Operation

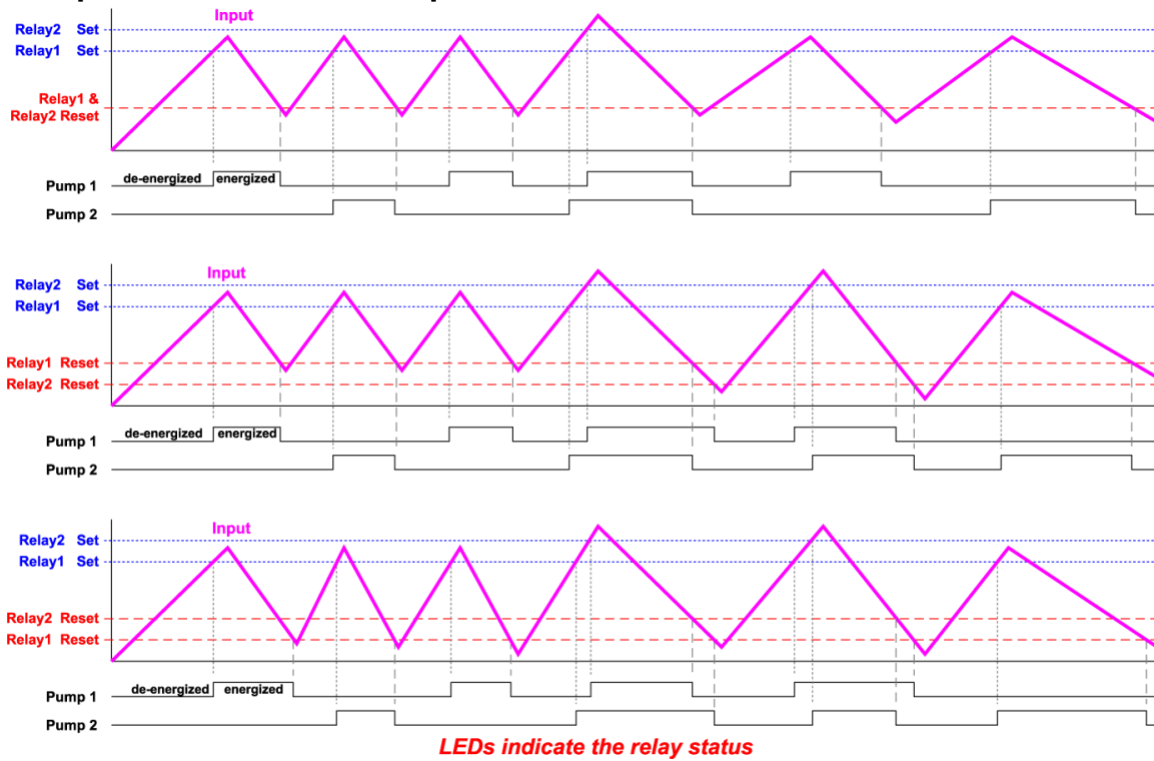

### Relay Sampling Operation

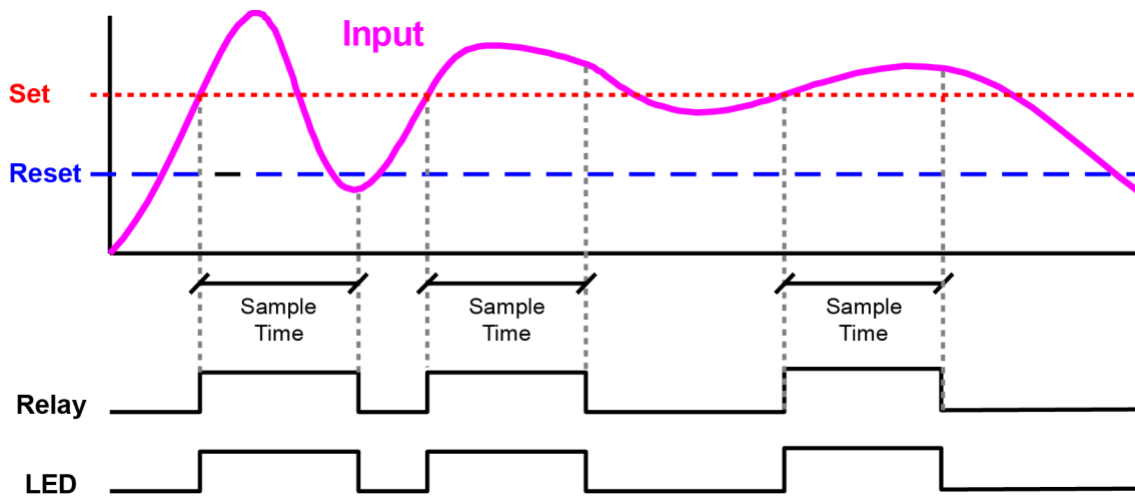

When the signal crosses the set point, the relay trips and the sample time starts. After the sample time has elapsed, the relay resets. The cycle repeats every time the set point is crossed, going up for high alarms and going down for low alarms.

The sample time can be programmed between 0.1 and 5999.9 seconds.

## Relay Operation Details

### Overview

The four-relays option for the meter expands its usefulness beyond simple indication to provide users with alarm and control functions. Typical applications include high and low temperature, level, pressure or flow alarms, control applications such as simple on/off pump control, and pump alternation control for up to 4 pumps. There are four basic ways the relays can be used:

1. High and Low Alarms with Latching or Non-Latching Relays
2. Simple On/Off Control with 100% Adjustable Deadband
3. Sampling (Based on Time)
4. Pump Alternation Control for up to 4 Pumps

### Relays Auto Initialization

When power is applied to the meter, the front panel LEDs and alarm relays will reflect the state of the input to the meter. The following table indicates how the alarm LEDs and relays will react on power-up based on the set and reset points:

Alarm #	HI or LO Alarm	Set Point	Reset Point	Power-Up Reading	Relay & LED
1	HI	1000	500	499	Off
2	LO	700	900	499	On
3	LO	250	400	499	Off
4	HI	450	200	499	On

### Fail-Safe Operation

The following table indicates how the relays behave based on the fail-safe selection for each relay:

Fail-Safe Selection	Non-Alarm State		Alarm State		Power Failure
	NO	NC	NO	NC	
Off	Open	Closed	Closed	Open	Relays go to non-alarm state
On	Closed	Open	Open	Closed	Relays go to alarm state

*Note: NO = Normally Open, NC = Normally Closed. This refers to the condition of the relay contacts when the power to the meter is off.*

## Front Panel LEDs

The alarm status LEDs on the front panel are available on all meters, even those without relays installed, and provide status indication for the following:

LED	Status
1	Alarm 1
2	Alarm 2
3	Alarm 3
4	Alarm 4

The meter is supplied with four alarm points that include front panel LEDs to indicate alarm conditions. This standard feature is particularly useful for alarm applications that require visual-only indication. The LEDs are controlled by the set and reset points programmed by the user. When the display reaches a set point for a high or low alarm, the corresponding alarm LED will turn on. When the display returns to the reset point the LED will go off. The front panel LEDs respond differently for latching and non-latching relays.

For non-latching relays, the LED is always off during normal condition and always on during alarm condition, regardless of the state of the relay (e.g. Relay acknowledged after alarm condition).

For latching relays, the alarm LEDs reflect the status of the relays, regardless of the alarm condition. The following tables illustrate how the alarm LEDs function in relation to the relays and the acknowledge button (Default: F3 key assigned to ACK).

### Latching and Non-Latching Relay Operation

The relays can be set up for latching (manual reset) or non-latching (automatic reset) operation.

Relay terminology for following tables	
Terminology	Relay Condition
On	Alarm (Tripped)
Off	Normal (Reset)
Ack	Acknowledged

The On and Off terminology does not refer to the status of the relay's coil, which depends on the fail-safe mode selected.

### WARNING

- In latching relay mode, if Fail-Safe is off, latched relays will reset (unlatch) when power is cycled.

### Non-Latching Relay (Αὐτο)

In this application, the meter is set up for automatic reset (non-latching relay). Acknowledging the alarm while it is still present has no effect on either the LED or the relay. When the alarm finally goes away, the relay automatically resets and the LED also goes off.

Automatic reset only		
Condition	LED	Relay
Normal	Off	Off
Alarm	On	On
Ack (No effect)	On	On
Normal	Off	Off

### Non-Latching Relay with Manual Reset (Α-η αβγ)

In this application, the meter is set up for automatic and manual reset at any time (non-latching relay). The LED and the relay automatically reset when the meter returns to the normal condition.

In addition, the relay can be manually reset while the alarm condition still exists, but the LED will stay on until the meter returns to the normal condition.

Automatic + manual reset at any time		
Condition	LED	Relay
Normal	Off	Off
Alarm	On	On
Normal	Off	Off
Next Alarm	On	On
Ack	On	Off
Normal	Off	Off

### Latching Relay (ΛΡεεΗ)

In this application, the meter is set up for manual reset at any time. Acknowledging the alarm even if the alarm condition is still present resets the relay and turns off the LED.

Manual reset any time		
Condition	LED	Relay
Normal	Off	Off
Alarm	On	On
Ack	Off	Off

### Latching Relay with Clear (Λε-εεε)

In this application, the meter is set up for manual reset only after the signal passes the reset point (alarm condition has cleared). Acknowledging the alarm while it is still present has no effect on either the LED or the relay. When the alarm is acknowledged after it returns to the normal state, the LED and the relay go off. Notice that the LED remains on, even after the meter returns to the normal condition. This is because, for latching relays, the alarm LED reflects the status of the relay, regardless of the alarm condition.

Manual reset only after alarm condition has cleared		
Condition	LED	Relay
Normal	Off	Off
Alarm	On	On
Ack (No effect)	On	On
Normal	On	On
Ack	Off	Off

### Light / Horn / Button Accessories



Add visible and audible ways to indicate alarm conditions on any Helios meter with the [MOD-PD2LH](#) Light / Horn / Button accessories. The light with built-in 85 dB horn, and button come mounted and wired to the Helios. Meter and accessories are ordered as separate items. See *Ordering Information* on page 6.



### Acknowledging Relays

There are three ways to acknowledge relays programmed for manual reset:

1. Via the programmable front panel function keys F1-F3 (Example: F3 assigned to ACK).

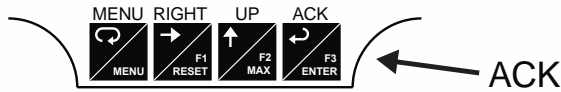

2. Remotely via a normally open push button wired to the F4 terminal.

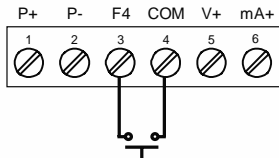

3. Remotely via a normally open push button wired to one of the digital inputs and the +5 V terminal on the digital I/O connections.

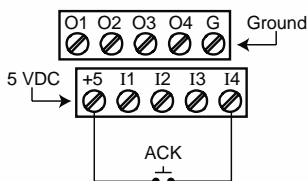

When the ACK button or the assigned digital input is closed, all relays programmed for manual reset are acknowledged.

### Acknowledging Relays with Remote Control Station

Relays may be remotely acknowledged by connecting the [PDA2361-A](#) to either the F4 terminal or a digital input as described above.



### Pump Alternation Control Applications (RL&Ern)

For pump control applications where two or more similar pumps are used to control the level of a tank or a well, it is desirable to have all the pumps operate alternately. This prevents excessive wear and overheating of one pump over the lack of use of the other pumps.

Up to 4 relays can be set up to alternate every time an on/off pump cycle is completed. The set points and reset points can be programmed, so that the first pump on is the first pump off.

### Application #1: Pump Alternation Using Relays 1 & 2

1. Relays 1 and 2 are set up for pump alternation.
2. Relays 3 and 4 are set up for low and high alarm indication.

Set and Reset Point Programming			
Relay	Set Point	Reset Point	Function
1	30.000	10.000	Controls pump #1
2	35.000	5.000	Controls pump #2
3	4.000	9.000	Controls low alarm
4	40.000	29.000	Controls high alarm

### Pump Alternation Operation

1. Pump #1 turns on when level reaches 30.000, when level drops below 10.000, pump #1 turns off.
2. The next time level reaches 30.000, pump #2 turns on, when level drops below 10.000, pump #2 turns off.
3. If the level doesn't reach 35.000, pump #1 and pump #2 will be operating alternately.
4. If pump #1 cannot keep the level below 35.000, pump #2 will turn on at 35.000, then as the level drops to 10.000, pump #1 turns off, pump #2 is still running and shuts off below 5.000.
5. Notice that with the set and reset points of pump #2 outside the range of pump #1, the first pump on is the first pump to go off. This is true for up to 4 alternating pumps, if setup accordingly.
6. Relay #3 will go into alarm if the level drops below 4.000 and relay #4 will go into alarm if the level exceeds 40.000.

### Application #2: Pump Alternation Using Relays 3 & 4

1. Relays 1 and 2 are set up for low and high alarm indication.
2. Relays 3 and 4 are set up for pump alternation.

Set and Reset Point Programming			
Relay	Set Point	Reset Point	Function
1	495	750	Controls low alarm
2	7500	6900	Controls high alarm
3	7000	900	Controls backup pump
4	6000	1000	Controls main pump

### Pump Alternation Visual Representation

The following graphics provide a visual representation of a typical pump alternation application with high and low alarm monitoring:

1. Relay #4 turns the main pump on at 6000 gallons and turns it off at 1000 gallons.

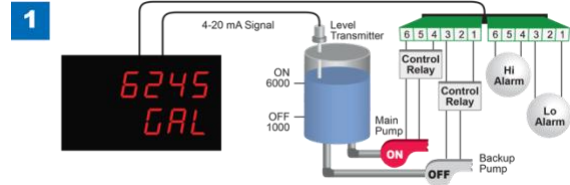

2. With the Pump Alternation feature activated, the next time the level reaches 6000 gallons, relay #3 transfers and starts the backup pump.

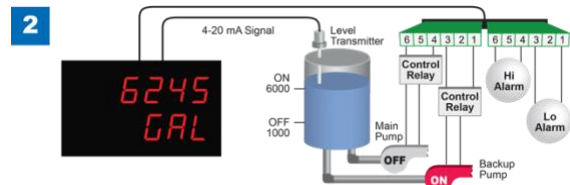

3. If the backup pump is not able to keep up, and the level reaches 7000 gallons, relay #4 transfers and starts the main pump as well.

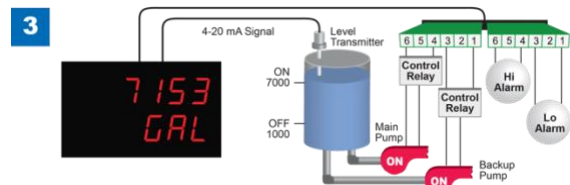

4. Relay #2 trips the High Level Alarm at 7500 gallons and resets at 6900 gallons.

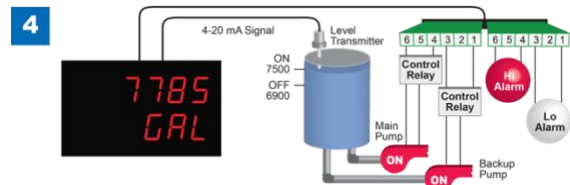

5. Relay #1 trips the Low Level Alarm at 495 gallons and resets at 750 gallons.

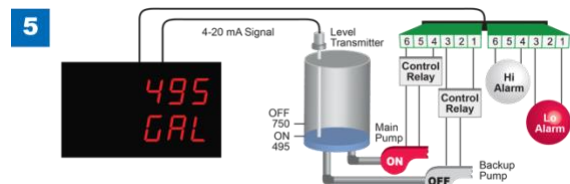

### Setting Up the Interlock Relay (Force On) Feature

Relays 1-4 can be set up as interlock relays. To set up the relays for the interlock feature:

1. Access the *Setup – Relay – Action* menu and set the action to off.

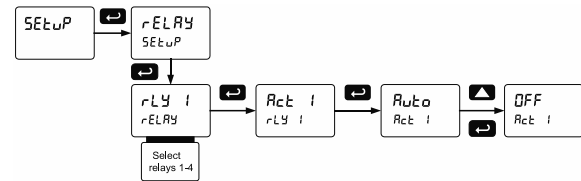

2. In the *Advanced features – User* menu program any of the digital inputs to *Force On* any of the internal relays (1-4).

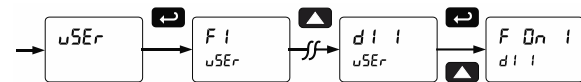

3. Connect a switch or dry contact between the +5V terminal and the corresponding digital input (di-1 to di-4) terminal.

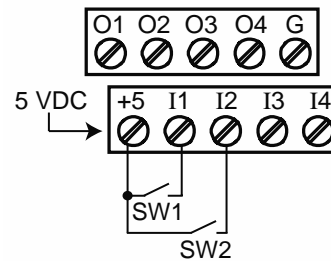

### Interlock Relay Operation Example

Relays 1 & 2 are configured to energize (their front panel LEDs are steady on) when SW1 & SW2 switches (above) are closed. If the contacts to these digital inputs are opened, the corresponding front panel LEDs flash indicating this condition. The processes being controlled by the interlock relay will stop, and will re-start only after the interlock relay is re-activated by the digital inputs (switches).

*Note: If multiple digital inputs are assigned to the same relay, then the corresponding logic is (AND) – i.e. both switches must be closed to activate the relay.*

### IMPORTANT

- If the digital inputs are assigned to the *Interlock Function*, then they cannot be used to program the meter remotely.

### Scaling the 4-20 mA Analog Output (Rout)

The 4-20 mA analog output can be scaled to provide a 4-20 mA signal for any display range selected.

No equipment is needed to scale the analog output; simply program the display values to the corresponding mA output signal.

The *Analog Output* menu is used to program the 4-20 mA output based on display values.

For further details, see *Setting Numeric Values* on page 26, *Analog Output Value for Loss of 4-20 mA Input (Loop Break)* on page 44.

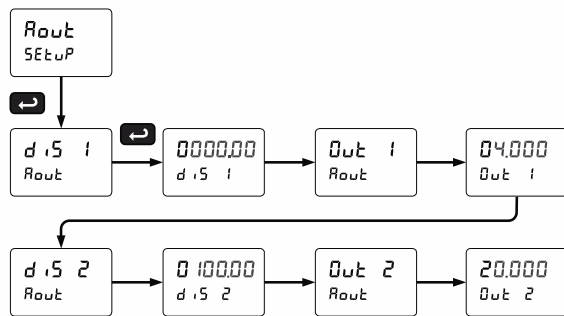

### Reset Menu (rESEt)

The *Reset* menu is used to reset the maximum or minimum reading (peak or valley) reached by the process; both may be reset at the same time by selecting “reset high & low” (rSEt HL). The tare value used to zero the display may be reset by selecting “reset tare” (rSEt tr).

### Manual Control Menu (Control)

The *Manual Control* menu is used to control the 4-20 mA analog output and the relays manually, ignoring the input. Each relay and analog output can be programmed independently for manual control. Selecting automatic control sets all relays and analog output for automatic operation.

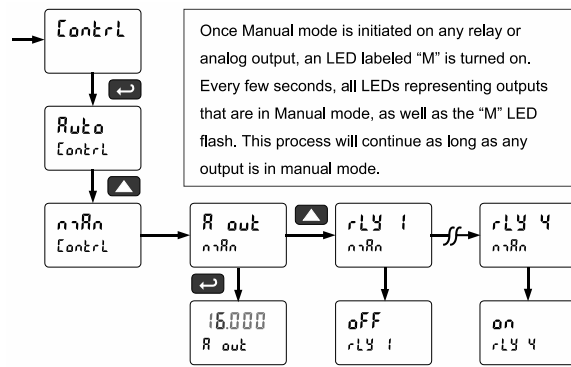

## Setting Up the Password (PR55)

The *Password* menu is used for programming three levels of security to prevent unauthorized changes to the programmed parameter settings.

- Pass 1: Allows use of function keys and digital inputs
- Pass 2: Allows use of function keys, digital inputs and editing set/reset points
- Pass 3: Restricts all programming, function keys, and digital inputs.

### Protecting or Locking the Meter

Enter the *Password* menu and program a six-digit password. For instructions on how to program numeric values see *Setting Numeric Values* on page 26.

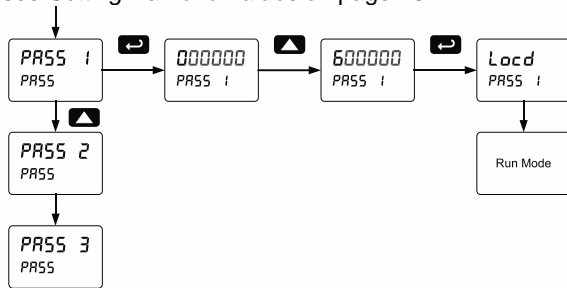

### Making Changes to a Password Protected Meter

If the meter is password protected, the meter will display the message *Locd* (*Locked*) when the Menu button is pressed. Press the Enter button while the message is being displayed and enter the correct password to gain access to the menu. After exiting the programming mode, the meter returns to its password protected condition.

## Disabling Password Protection

To disable the password protection, access the *Password* menu and enter the correct password twice, as shown below. The meter is now unprotected until a new password is entered.

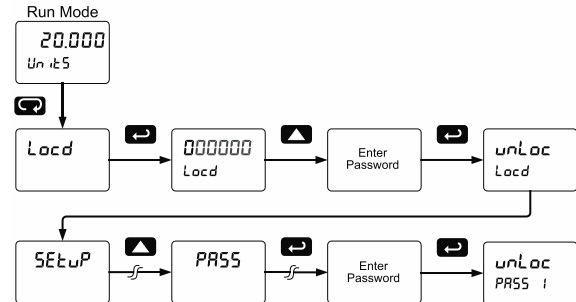

If the correct six-digit password is entered, the meter displays the message *unLoc* (*unlocked*) and the protection is disabled until a new password is programmed.

If the password entered is incorrect, the meter displays the message *Locd* (*Locked*) for about two seconds, and then it returns to Run Mode. To try again, press Enter while the *Locked* message is displayed.

### Did you forget the password?

The password may be disabled by entering a master password once. If you are authorized to make changes, enter the master password 508655 to unlock the meter.

### Advanced Features Menu

To simplify the setup process, functions not needed for most applications are located in the *Advanced Features* menu. Press and hold the Menu button for three seconds to access the advanced features of the meter.

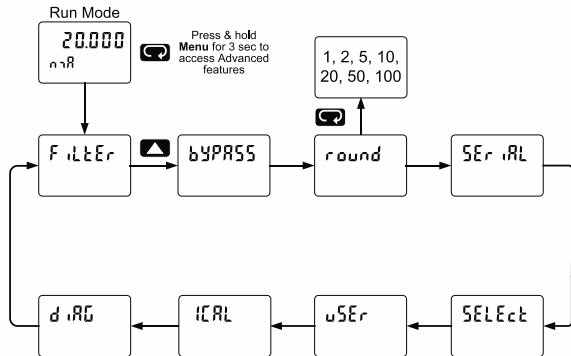

### Advanced Features Menu & Display Messages

The following table shows the functions and messages of the *Advanced Features* menu in the order they appear in the menu.

Advanced Features Menu & Display Messages		
Display	Parameter	Action/Setting
Filter	Filter	Set noise filter value
bYPASS	Bypass	Set filter bypass value
round	Round	Set the rounding value for display variables
SERIAL	Serial	Set serial communication parameters
Slave ID	Slave ID	Set slave ID or meter address
baud	Baud rate	Select baud rate
transmit delay	Transmit delay	Set transmit delay for serial communication
PARITY	Parity	Select parity Even, Odd, or None with 1 or 2 stop bits
time byte	Time byte	Set byte-to-byte timeout
SELECT	Select	Enter the Select menu (function, cutoff, out)
Function	Input signal conditioning	Select linear, square root, programmable exponent, or round horizontal tank function
Linear	Linear	Set meter for linear function and select number of linearization points
PV 1	PV1	Select PV1 number of linearization points
PV 2	PV2	Select PV2 number of linearization points

Advanced Features Menu & Display Messages		
Display	Parameter	Action/Setting
no PLS	Number of points	Set PV1 for 2 to 32-point linearization Set PV2 for 2 to 8-point linearization
SURF	Square root	Set meter for square root extraction
Pr o g E	Programmable exponent	Set meter for programmable exponent and enter exponent value
rh t	Round horizontal tank	Set meter for round horizontal tank volume calculation
inch	Dimension	Calculate volume in gallons
cm	Dimension	Calculate volume in liters
d i a m	Diameter	Enter the tank's diameter in inches
LEnGth	Length	Enter the tank's length in inches
Cutoff	Cutoff	Set low-flow cutoff
RoutPr	Analog output programming	Program analog output parameters
Source	Source	Select source for the 4-20 mA output
OverRng	Overrange	Program mA output for display overrange
UnderRng	Underrange	Program mA output for display underrange
brk	Break	Set analog output value if input loop break is detected
max	Maximum	Program maximum mA output allowed
min	Minimum	Program minimum mA output allowed
Cal	Calibrate	Calibrate 4-20 mA output (internal reference source used for scaling the output)
4 mA	4 mA output	Enter mA output value read by milliamp meter with at least 0.001 mA resolution
20 mA	20 mA output	Enter mA output value read by milliamp meter with at least 0.001 mA resolution
uSER	User I/O	Assign function keys and digital I/O
F1	F1 function key	Assign F1 function key
F2	F2 function key	Assign F2 function key
F3	F3 function key	Assign F3 function key
F4	F4 function	Assign F4 function (digital input)
d i 1	Digital input 1	Assign digital input 1 – 4
d o 1	Digital output 1	Assign digital output 1 – 4

Advanced Features Menu & Display Messages		
Display	Parameter	Action/Setting
Internal	Internal source calibration	Enter internal source calibration (used for scaling the meter without a signal source)
Current	Current calibration	Calibrate 4-20 mA current input (internal reference source used for scaling the input)
Current low	Current low	Calibrate low current input (e.g. 4 mA)
Current high	Current high	Calibrate high current input (e.g. 20 mA)
Voltage	Voltage calibration	Calibrate voltage input
Voltage low	Voltage low	Calibrate low voltage input (e.g. 0 V)
Voltage high	Voltage high	Calibrate high voltage input (e.g. 10 V)
Diagnostics	Diagnostics	Display parameter settings
LED test	LED test	Test all LEDs (press menu to exit test)
Info	Information	Display software number and version
Erase	Erase	Erase MeterView Pro SW stored in meter's memory

### Noise Filter (Filter)

The noise filter is available for unusually noisy signals that cause an unstable process variable display. The noise filter averages the input signal over a certain period. The filter level determines the length of time over which the signal is averaged. The filter level can be set between 2 and 199. The higher the filter level, the longer the averaging time and so the longer it takes the display to settle to its final value. Setting the filter level to zero disables the filter function.

### Noise Filter Bypass (Bypass)

The noise filter bypass changes the behavior of the meter so that small variations in the signal are filtered out but large abrupt changes in the input signal are displayed immediately. The bypass value determines the minimum amount of signal change to be displayed immediately. All signal changes smaller than the bypass value are filtered or averaged by the meter. The noise filter bypass may be set between 0.1 and 99.9% of full scale.

### Rounding Feature (Round)

The rounding feature is used to give the user a steadier display with fluctuating signals. Rounding is used in addition to the filter function.

Rounding causes the display to round to the nearest value according to the rounding selected. See examples below:

Rounding Selection	Actual Value	Display Value	Actual Value	Display Value
1	12.022	12.022	12.023	12.023
5	12.022	12.020	12.023	12.025
10	12.024	12.020	12.025	12.030

### Modbus RTU Serial Communications (Serial)

The meter is equipped with serial communications capability as a standard feature using Modbus RTU Serial Communication Protocol.

The meter may be connected to a PC for initial configuration via the on-board USB connection. For ongoing digital communications with a computer or other data terminal equipment, use the RS-485 connection with the appropriate serial converter; see *Ordering Information* on page 6 for details.

#### CAUTION

- DO NOT** connect any equipment to the RJ45 M-LINK connector. Otherwise damage will occur to the equipment and the meter.
- DO NOT** disconnect the RJ45 connector located to the left of the power terminal block. Doing so will disable the on-board digital I/O, and the RS-485 serial communications.

#### Notes:

- More detailed instructions are provided with each optional serial communications adapter.
- Refer to the Helios Modbus Register Tables located at [www.predig.com](http://www.predig.com) for details.

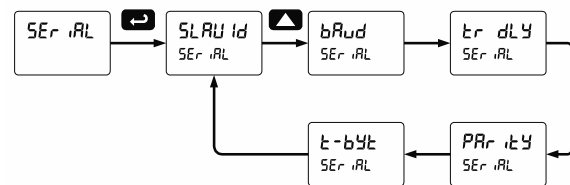

When using more than one meter in a multi-drop mode, each meter must be provided with its own unique address. The meter address (Slave ID) may be programmed between 1 and 247. The transmit delay may be set between 0 and 199 ms. The parity can be set to even, odd, or none with 1 or 2 stop bits.



### Select Menu (SELEct)

The *Select* menu is used to select the input signal conditioner applied to the input (linear, square root, programmable exponent, or round horizontal tank), low-flow cutoff, and analog output programming. The multi-point linearization is part of the linear function selection.

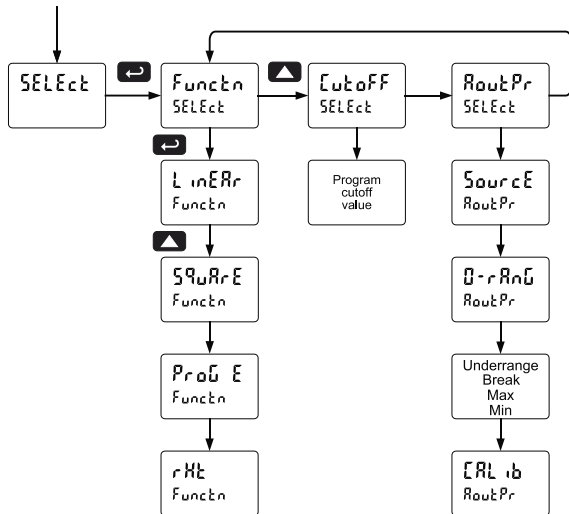

### Input Signal Conditioning (Functn)

The *Function* menu is used to select the input signal conditioner applied to the input: linear, square root, programmable exponent, or round horizontal tank volume calculation. The multi-point linearization is part of the linear function selection. Meters are set up at the factory for linear function with 2-point linearization. The linear function provides a display that is linear with respect to the input signal.

### Square Root Linearization (SQURrE)

The square root function can be used to linearize the signal from a differential pressure transmitter and display flow rate in engineering units.

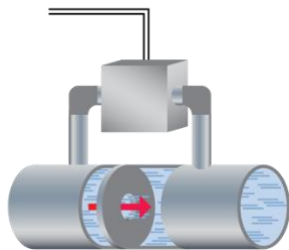

### Programmable Exponent Linearization (PrOG E)

The programmable exponent can be used to linearize the signal from level transmitters in open-channel flow applications using weirs and flumes. For more information on how the Programmable Exponent Linearization feature works, see the [PD6200](#) manual.

### Multi-Point Linearization (L inERr)

Meters are set up at the factory for linear function with 2-point linearization. Up to 32 linearization points can be selected for PV1 under the linear function. The multi-point linearization can be used to linearize the display for non-linear signals such as those from level transmitters used to measure volume in odd-shaped tanks or to convert level to flow using weirs and flumes with complex exponent. If the dual-scale level feature has been selected, the menus for PV1 & PV2 are enabled. PV2 can be programmed with up to 8 linearization points.

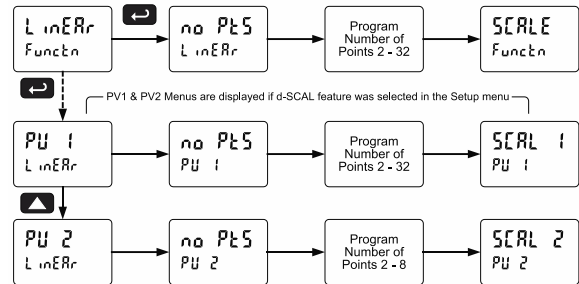

### Round Horizontal Tank Linearization (rHt)

This function automatically calculates the volume in a round horizontal tank with flat ends.

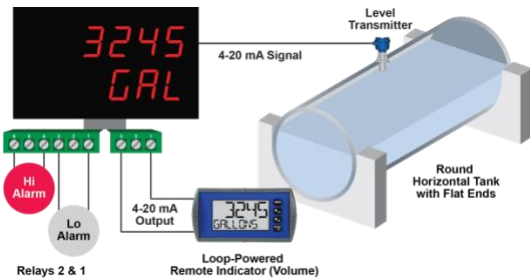

Set the display for the desired decimal point and engineering units before entering the round horizontal tank function. Select units, inches or cm for the tank dimensions. Enter the diameter and the length in inches and the results are calculated automatically in US gallons. Enter the diameter and length in cm and the results are calculated automatically in liters. The meter can be scaled to display the volume in any engineering unit.

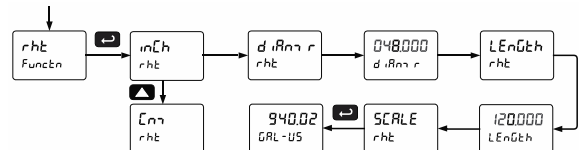

*Note: After Scale is displayed continue pressing the Enter button until the meter completes the scaling of the input and display values.*



**Changing the Volume from Gallons to Liters**

In the above graphic, entering 48" for the diameter and 120" for the length of the round horizontal tank, the meter automatically calculates that the volume of the tank is 940.02 gallons.

1. Convert gallons to liters  
 1 US gallon = 3.7854 L  
 940.02 gal = 3558.4 L
2. Go to the *Setup* menu and change the decimal point to 1 decimal.
3. Go to the *Program – Scale* menu and press Enter until 0.5 2 is shown on the main display.
4. Press Enter and change the display 2 value to 3558.4.
5. The meter is now displaying the volume in liters.

*Note: The display can be scaled to display the volume in any engineering units.*

Another way to display the volume in liters is to enter the dimensions in cm. The meter automatically calculates the volume in liters.

**Low-Flow Cutoff (Cutoff)**

The low-flow cutoff feature allows the meter to be programmed so that the often-unsteady output from a differential pressure transmitter, at low flow rates, always displays zero on the meter.

The cutoff value may be programmed from 0.1 to 999999. The meter will display zero below the cutoff value. Programming the cutoff value to zero disables the cutoff feature. The cutoff can be disabled to display negative values.

**Analog Output Programming (RoutPr)**

The *Analog Output Programming* menu is used to program the behavior of the 4-20 mA output. The following parameters and functions are programmed in this menu:

1. Source: Source for generating the 4-20 mA output (e.g. PV)
2. Overrange: Analog output value with display in overrange condition
3. Underrange: Analog output value with display in underrange condition
4. Break: Analog output value when loop break is detected
5. Max: Maximum analog output value allowed regardless of input
6. Min: Minimum analog output value allowed regardless of input
7. Calibrate: Calibrate the internal 4-20 mA source reference used to scale the 4-20 mA output

**Analog Output Source**

The source for generating the 4-20 mA output may be assigned to the process variable, maximum or minimum value reached by the process, one of the set points, or the Modbus PV input.

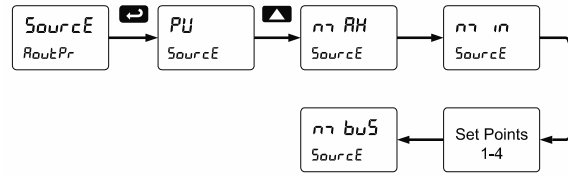

**Analog Output Value for Loss of 4-20 mA Input (Loop Break)**

The AoutPr - Break menu is used to force the analog output to go to a user-specified mA value if a break condition is detected in the 4-20 mA input loop. Selecting Ignore causes the mA output to go to the minimum value.

**Analog Output Calibration**

To perform the analog output calibration, it is recommended to use a milliamp meter with a resolution of at least 0.1 µA to measure the output current. The values saved internally during this procedure are used for scaling the 4-20 mA output in the *Setup* menu.

**Analog Output Calibration Procedure**

1. Wire the PD2-6000 4-20 mA output to a current loop that includes a power supply (internal or external 12 to 24 VDC), and the mA input on the digital meter. See *Figure 25. 4-20 mA Output Connections* on page 21 for details.
2. Turn on all devices. Allow for a 15 to 30 minute warm-up.
3. Go to the *Advanced Features* menu, and navigate to the *Analog Output Programming (RoutPr)* → *Calibration (CALIB)* menu and press **Enter**.
4. The display will show 4 mA. The PD2-6000 mA output should now be close to 4 mA. Press Enter and the display will show 04.000. Enter the actual value read by the digital mA meter and press **Enter**.
5. The display will show 20 mA. The PD2-6000 mA output should now be close to 20 mA. Press **Enter** and the display will show 20.000. Enter the actual value read by the digital mA meter and press **Enter**.
6. The meter will now calculate the calibration factors and store them.
7. Press **Menu** to exit and return to Run mode.

### Programmable Function Keys User Menu (uSEr)

The User menu allows the user to assign the front programming buttons function keys F1, F2, and F3, the digital input F4 (located on the input signal connector), and four digital inputs (located on the digital I/O connector) to access most of the menus or to activate certain functions immediately (e.g. reset max & min, hold relay states, etc.). This allows the meter to be greatly customized for use in specialized applications.

The four digital outputs can be assigned to a number of actions and functions executed by the meter (i.e. alarms, relay acknowledgement, reset max, min, or max & min, tare, and reset tare). The digital outputs can be used to trigger external alarms or lights to indicate these specific events.

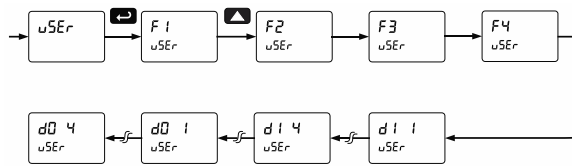

### Function Keys & Digital I/O Available Settings

Refer to the following table for descriptions of each available function key or digital I/O setting.

Display	Description
r 5t H i	Reset the stored maximum display value
r 5t L o	Reset the stored minimum display value
r 5t H L	Reset the stored maximum & minimum display values
t R r E	Capture tare and zero the display
r 5t t r	Reset captured tare and resume normal operation
r E L R Y	Directly access the relay menu
5 E t i *	Directly access the set point menu for relay 1 (*through 4)
r L Y d	Disable all relays until a button assigned to <i>enable relays (r L Y E)</i> is pressed
r L Y E	Enable all relays to function as they have been programmed
d H o l d	Hold current relay states and analog output as they are until a button assigned to <i>enable relays (r L Y E)</i> is pressed
d H o l d	Hold the current display value, relay states, and analog output momentarily while the function key or digital input is active. The process value will continue to be calculated in the background.
L n i H i	Display maximum display value on line 1

Display	Description
L n i L o	Display minimum display value on line 1
L n i H L	Display maximum & minimum display values on line 1
L n 2 H i	Display maximum display value on line 2
L n 2 L o	Display minimum display value on line 2
L n 2 H L	Display maximum & minimum display values on line 2
F O n i *	Force relay 1 (*through 4) into the on state. This function is used in conjunction with a digital input to achieve interlock functionality. See <i>Setting Up the Interlock Relay (Force On) Feature</i> on page 38 for details.
E n t e r L	Directly access the control menu
d i S A b L	Disable the selected function key or digital I/O
R c H	Acknowledge all active relays that are in a manual operation mode such as auto-manual or latching
r E S E t	Directly access the reset menu
n r E n u	Mimic the menu button functionality (digital inputs only)
r i G H t	Mimic the right arrow/F1 button functionality (digital inputs only)
u P	Mimic the up arrow/F2 button functionality (digital inputs only)
E n t e r	Mimic the enter/F3 button functionality (digital inputs only)
R L n i i *	Provide indication when alarm 1 (*through 4) has been triggered (digital outputs only)

### Tare (t R r E)

The tare function zero's out the display. In the case of scale weight, tare is used to eliminate container weight and provide net weight readings. There are two tare functions; Capture Tare and Reset Tare. When the capture tare function is used, the display reading is offset by the displayed amount to make the displayed value zero. This modified display value is the net value. The originally displayed value without the tare offset is the gross value. Both may be chosen as a display option.



Reset tare removes the display offset of the net value, and the gross and net values become the same until a new capture tare is entered.

### Internal Source Calibration (I<sub>ERL</sub>)

The meter is **factory calibrated** prior to shipment for milliamps and volts with calibration equipment that is certified to NIST standards.

The use of calibrated signal sources is necessary to calibrate the internal source of the meter. The meter's internal source is what allows the user to scale the meter without applying a signal. Check calibration of the meter at least every 12 months. Each input must be recalibrated separately.

**Notes:**

1. If meter is in operation and it is intended to accept only one input type (e.g. 4-20 mA), recalibration of other input is not necessary.
2. Allow the meter to warm up for at least 15 minutes before performing the internal source calibration procedure.

The *Internal calibration* menu is part of the *Advanced Features* menu.

1. Press and hold the Menu button for three seconds to access the advanced features of the meter.
2. Press the Up arrow button to scroll to the *Internal calibration* menu (I<sub>ERL</sub>) and press Enter.
3. The meter displays either current calibration (I<sub>ERL</sub>) or voltage calibration (V<sub>ERL</sub>), according to the input setup. Press Enter to start the calibration process.

**Example of Internal Calibration for current input:**

4. The meter displays *low* input current message (I<sub>Lo</sub>). Apply the low input signal and press Enter. The display flashes for a moment while the meter is accepting the low input signal.
5. After the display stops flashing, a number is displayed with the leftmost digit brighter than the rest. The bright digit is the active digit that can be changed by pressing the Up arrow button. Press the Right arrow button to move to the next digit.
6. Set the display value to correspond to the input signal being calibrated, typically 4.000 mA.
7. The display moves to the *high* input calibration (I<sub>Hi</sub>). Apply the high input signal and press Enter.
8. Set the display for the high input calibration, in the same way as it was set for the low input calibration, typically 20.000 mA.

The following graphic shows the calibration of the current input. The voltage input is calibrated in a similar way.

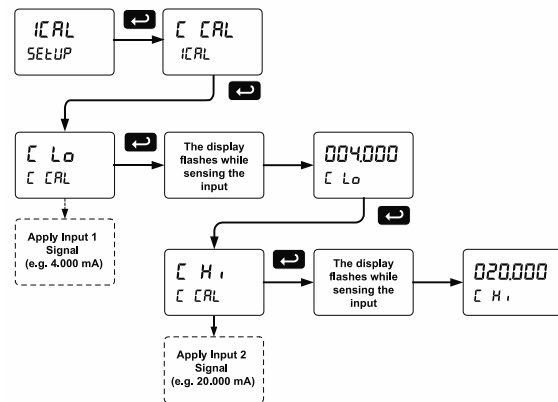

**Tips:**

- Low and high input signals can be any valid values within the range of the meter.
- Observe minimum input span requirements between input 1 and input 2.
- Low input should be less than high input signal. However, the low display can be higher than the high display (i.e. 4-20 mA = 100.0 to 0.0).

### Error Message (Error)

An error message indicates that the calibration or scaling process was not successful.

After the error message is displayed, the meter reverts to the input prior to the failure during calibration or scaling and to input 1 during internal calibration, allowing the appropriate input signal to be applied or programmed.

The error message might be caused by any of the following conditions:

1. Input signal is not connected to the proper terminals or it is connected backwards\*.
2. Wrong signal selection in *Setup* menu\*.
3. Minimum input span requirements not maintained.
4. Input 1 signal inadvertently applied to calibrate input 2\*.

\*Not relevant when scaling the meter.

### Minimum Input Span

The minimum input span is the minimum difference between input 1 and input 2 signals required to complete the calibration or scaling of the meter.

Input Range	Input 1 & Input 2 Span
4-20 mA	0.15 mA
±10 VDC	0.10 VDC

## Meter Operation

The meter is capable of accepting current (0-20 mA, 4-20 mA) and voltage signals (0-5 V, 1-5 V, 0-10 V, ±10 V) and displaying these signals in engineering units from -99999 to 999999 (e.g. a 4-20 mA signal could be displayed as -50.000 to 50.000).

The dual-line display can be customized for the user's specific application. Typically, the main display is used for the process variable; while the second display is used for engineering units, custom legend, or set point indication.

The analog input can be scaled to display the process in two different scales; for example: with  $d-5\text{[RL]}$  enabled, the main display could indicate level in feet and the second display could indicate the volume in gallons.

Additionally, the meter can be set up to display the analog input on the main display and the Modbus input on the second display. The relays and analog output can be programmed to operate from the Modbus PV input.

## Button Operation

Button Symbol	Description
	Press to enter or exit Programming Mode, view settings, or exit max/min readings
	Press to reset max/min readings or other parameter/function assigned through the User menu
	Press to display max/min readings or other parameter/function assigned through the User menu
	Press to acknowledge relays or other parameters/function assigned through the User menu

## Function Keys Operation

During operation, the programmable function keys operate according to the way they have been programmed in the *Advanced Features – User menu*. See *Programmable Function Keys User Menu (u5Er)* on page 45 for details.

The table above shows the factory default settings for F1, F2, and F3.

## Digital Inputs Operation

Five (5) digital inputs, F4, DI-1 to DI-4, come standard on the meter. These digital inputs are programmed identically to function keys F1, F2, and F3. The inputs are triggered with a contact closure to +5 in the case of digital inputs 1-4 or with an active high signal, see *Digital I/O Connections* on page 20 for details. The F4 is triggered with a contact closure to COM or with an active low signal. During operation, digital inputs operate according to the way they are programmed in the *Advanced Features – User menu*. See *Programmable Function Keys User Menu (u5Er)* on page 45 for details.

## Maximum/Minimum Readings

The max & min readings (peak & valley) reached by the process can be displayed either continuously or momentary:

1. Display briefly by assigning to the F1-F3 function keys or to the digital inputs in the *User menu*.
2. Display continuously by assigning either display to max/min through the *Display menu*.

Any of the F1-F3 function keys (buttons) and the digital inputs can be programmed to reset the max & min readings. The meters are set at the factory to display the max reading by pressing the Up arrow/F2 button and to use the Right arrow/F1 button to access the *Reset menu*.

### To display max reading using function key with factory defaults:

1. Press Up arrow/F2 button to display maximum reading since the last reset/power-up.
2. To reset max/min press Right arrow/F1 button to access the Reset menu. The max & min displays are reset to actual values.
3. Press Menu to exit max/min display reading.

### To display max/min readings continuously:

Assign either display to Max ( $d H i$ ), Min ( $d L o$ ), or toggle between Max and Min ( $d H L$ ) every 10 seconds.

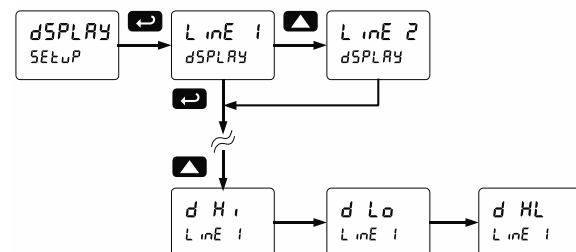

## Troubleshooting

The rugged design and the user-friendly interface of the meter should make it unusual for the installer or operator to refer to this section of the manual. However, due to the many features and functions of the meter, it's possible that the setup of the meter does not agree with what an operator expects to see. If the meter is not working as expected, refer to the *Diagnostics* menu and recommendations below.

### Diagnostics Menu (d rL)

The *Diagnostics* menu is located in the *Advanced Features* menu, to access *Diagnostics* menu see *Advanced Features Menu* on page 41.

This menu allows the user to test the functionality of all the meter LEDs, check the meter's software and version information, and erase the MeterView Pro software installation files from the meter. Press the Enter button to view the settings and the Menu button to exit at any time.

For a description of the diagnostic messages, see *Advanced Features Menu & Display Messages* on page 41.

### Testing the Display LEDs

To test all LEDs on the display:

1. Go to the *Diagnostics* menu (d rL) and press Enter button.
2. Press Up arrow button and scroll to *LED Test* menu (LEd t)
3. Press the Enter button to activate the LED Test. The meter will cycle through all digits, decimal points, and relay indicators to enable the operator to check that all LEDs are functioning properly.
4. Press the Enter button again to access the *Information* menu (InF o) or press the Menu button to return to Run Mode.

### Determining Software Version

To determine the software version of a meter:

1. Go to the *Diagnostics* menu (d rL) and press Enter button.
2. Press Up arrow button and scroll to *Information* menu (InF o).
3. Press Enter to access the software number (SF t) and version (vEr) information. Write down the information as it is displayed. Continue pressing Enter until all the information is displayed.
4. The meter returns to Run Mode after displaying all the settings.

## Reset Meter to Factory Defaults

When the parameters have been changed in a way that is difficult to determine what's happening, it might be better to start the setup process from the factory defaults.

### Instructions to load factory defaults:

1. Enter the *Advanced Features* menu. See *Advanced Features Menu* on page 41.
2. Press Up arrow to go to *Diagnostics* (d rL) menu
3. Press and hold Right arrow for three seconds, press Enter when display flashes rESEt.  
*Note: If Enter is not pressed within three seconds, the display returns to the Diagnostics menu.*
4. The meter goes through an initialization sequence (similar as on power-up), and loads the factory default settings.

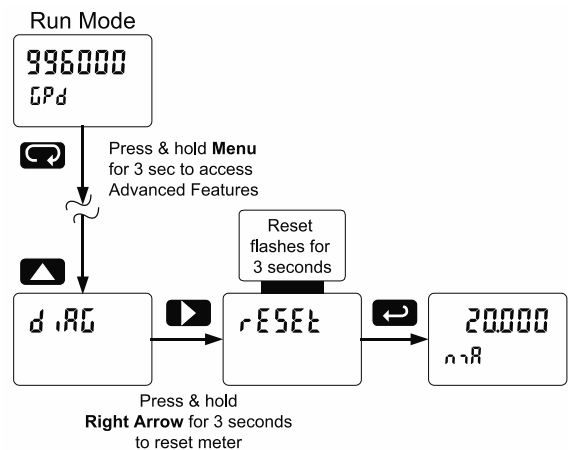

### Factory Defaults & User Settings

The following table shows the factory setting for most of the programmable parameters on the meter.

Parameter	Display	Default Setting
Input type	Input	4-20 mA
Dual-scale feature	dscale	No (Single scale)
Filter	Filter	70
Bypass	bypass	0.2
Function	Function	Linear
Number of points	nopts	2
Programming	Prog	Scale
Input 1	inp 1	4.000 mA
Display 1	dis 1	4.000
Input 2	inp 2	20.000 mA
Display 2	dis 2	20.000
Decimal point	dddd	3 places
Cutoff value	cutoff	0.0 (disabled)
Display assignment	display	
Display Line 1	line 1	PV: Process variable
Display Line 2	line 2	Eng unit default= mA
Display intensity	diint	6
Relay 1 action	rel 1	Automatic
Relay 1 set point	set 1	1.000
Relay 1 reset point	rst 1	0.500
Relay 2 action	rel 2	Automatic
Relay 2 set point	set 2	2.000
Relay 2 reset point	rst 2	1.500
Relay 3 action	rel 3	Automatic
Relay 3 set point	set 3	3.000
Relay 3 reset point	rst 3	2.500
Relay 4 action	rel 4	Automatic
Relay 4 set point	set 4	4.000
Relay 4 reset point	rst 4	3.500
Fail-safe relay 1	fls 1	Off
Fail-safe relay 2	fls 2	Off
Fail-safe relay 3	fls 3	Off
Fail-safe relay 4	fls 4	Off
On delay relay 1	on 1	0.0 sec
Off delay relay 1	off 1	0.0 sec
On delay relay 2	on 2	0.0 sec
Off delay relay 2	off 2	0.0 sec

Parameter	Display	Default Setting
On delay relay 3	on 3	0.0 sec
Off delay relay 3	off 3	0.0 sec
On delay relay 4	on 4	0.0 sec
Off delay relay 4	off 4	0.0 sec
Loop break relay 1	lbrk 1	Ignore
Loop break relay 2	lbrk 2	Ignore
Loop break relay 3	lbrk 3	Ignore
Loop break relay 4	lbrk 4	Ignore
Display 1 analog out	dis 1	4.000
Output 1 value	out 1	4.000 mA
Display 2 analog out	dis 2	20.000
Output 2 value	out 2	20.000 mA
Source analog output	source	Process Variable
Overrange output	orrng	21.000 mA
Underrange output	urrng	3.000 mA
Loop break output	lbrk	1.000 mA
Maximum output	max	23.000 mA
Minimum output	min	1.000 mA
Slave ID (Address)	slvid	247
Baud rate	brud	9600
Transmit delay	tr dly	50 ms
Parity	prty	Even
Byte-to-byte timeout	b-byt	010 (0.1 sec)
F1 function key	F1	Reset max & min
F2 function key	F2	Line 1: Max (Hi)
F3 function key	F3	Acknowledge relays
F4 function	F4	Acknowledge relays
Digital input 1	di 1	Menu
Digital input 2	di 2	Right arrow
Digital input 3	di 3	Up arrow
Digital input 4	di 4	Enter
Digital output 1	do 1	Alarm 1
Digital output 2	do 2	Alarm 2
Digital output 3	do 3	Alarm 3
Digital output 4	do 4	Alarm 4
Password 1	prsw 1	000000 (unlocked)
Password 2	prsw 2	000000 (unlocked)
Password 3	prsw 3	000000 (unlocked)



## Troubleshooting Tips

This meter is a highly sophisticated instrument with an extensive list of features and capabilities. If the programming buttons are used to program the meter, it may be a difficult task to keep everything straight. That is why we strongly recommend the use of the free [MeterView Pro](#) software for all programming activities. A USB cable is provided with the meter for programming with MeterView Pro software.

If you have programmed the meter with the programming buttons and it is not working as intended, try re-programming the meter using MeterView Pro software.

Symptom	Check/Action
No display at all	Check power at power connector
Not able to change setup or programming, <b>L o c k</b> is displayed	Meter is password-protected, enter correct six-digit password to unlock or Master Password of 508655.
Meter does not respond to input change	If a <i>Low-Flow Cutoff</i> Value has been programmed, the meter will display zero below that point, regardless of the input – which can appear like the meter is not responding to an input change. Check to make sure the problem is not being caused by an undesired low-flow cutoff value. To prevent the display from showing a negative value, set the low-flow cutoff to a value greater than zero.
Meter displays error message during calibration ( <b>E r r o r</b> )	Check: 1. Signal connections 2. Input selected in <i>Setup</i> menu 3. Minimum input span requirements
Meter displays 1. <b>999999</b> 2. <b>-99999</b>	Check: 1. Input selected in <i>Setup</i> menu 2. Corresponding signal at Signal connector
Display is unstable	Check: 1. Input signal stability and value 2. Display scaling vs. input signal 3. Filter and bypass values (increase)
Display response is too slow	Check filter and bypass values
Display reading is not accurate	Check: 1. Input signal conditioner selected: Linear, square root, etc. 2. Scaling or calibration
Display does not respond to input changes, reading a fixed number	Check: 1. Display assignment, it might be displaying max, min, or set point.
Display alternates between 1. <b>H i</b> and a number 2. <b>L o</b> and a number	Press Menu to exit max/min display readings.
Relay operation is reversed	Check: 1. Fail-safe in <i>Setup</i> menu 2. Wiring of relay contacts
Relay and status LED do not respond to signal	Check: 1. Relay action in <i>Setup</i> menu 2. Set and reset points
Flashing relay status LEDs	Relays in manual control mode or relay interlock switches opened.
Meter not communicating with application programs	Check: 1. Serial adapter and cable 2. Serial settings 3. Meter address and baud rate
If the display locks up or the meter does not respond at all	Cycle the power to reboot the microprocessor.
Other symptoms not described above	Call Technical Support for assistance.

*Note: Certain sequences of events can cause unexpected results. To solve these issues, it is best to start fresh from factory defaults and use the manual as a step by step programming guide, rather than a random approach to programming. To reset the meter to factory defaults, see [Reset Meter to Factory Defaults](#) on page 48. In addition, for best results, we recommend using the free [MeterView Pro](#) software for all programming needs.*



## Contact Precision Digital

### Technical Support

Call: (800) 610-5239 or (508) 655-7300

Fax: (508) 655-8990

Email: [support@predig.com](mailto:support@predig.com)

### Sales Support

Call: (800) 343-1001 or (508) 655-7300

Fax: (508) 655-8990

Email: [sales@predig.com](mailto:sales@predig.com)

### Place Orders

Email: [orders@predig.com](mailto:orders@predig.com)

For the latest version of this manual please visit

[www.predig.com](http://www.predig.com)

### PRECISION DIGITAL CORPORATION

233 South Street • Hopkinton MA 01748 USA

Tel (800) 343-1001 • Fax (508) 655-8990

[www.predig.com](http://www.predig.com)

