

Eliminate Deposits from Your Heavy Duty System



viscosity grades
ISO 150-320



flashpoint
216°C

PROTECTION FOR YOUR MACHINE AND FLUID

DECON HD is a blend of Group IV and Group V chemistries. DECON HD is ideally suited for lubricants within the viscosity ranges of **ISO 150-320** with treat rates of **6-10%**. In addition to having outstanding solubility characteristics, DECON HD also has:

- Rapid reduction of the oil's varnish potential as measured by MPC, UC and Particle Counts.
- Excellent oxidation stability and deposit control characteristics.
- No adverse impact on the in-service oil's performance (i.e. air release, foam, demulsibility, etc.).

ELIMINATE DEPOSITS FROM YOUR FLUID AND SYSTEM

Decontamination

- Provides efficient cleaning of systems in between fluid changes.
- Quickly and safely dissolves organic deposits from the machine internals.

Deposit Control

- Enhances the deposit control performance of in-service fluids.
- Long-term system protection against deposits, sludge & varnish.

DECON HD WORKS BY RAPIDLY DISSOLVING OIL DEGRADATION DEPOSITS

with **SOLVANCER**[®]
A PATENT PENDING TECHNOLOGY

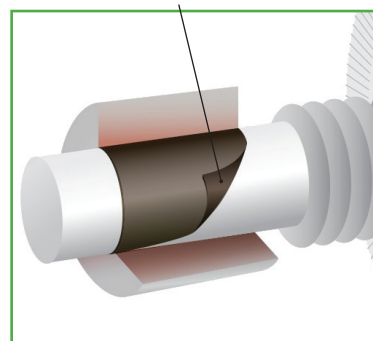

KEY FEATURES

DECON HD dissolves varnish.

DECON HD provides an immediate impact on system Decontamination.

DECON HD protects the oil from forming varnish, providing long-term Deposit Control performance.

decon[™] HD

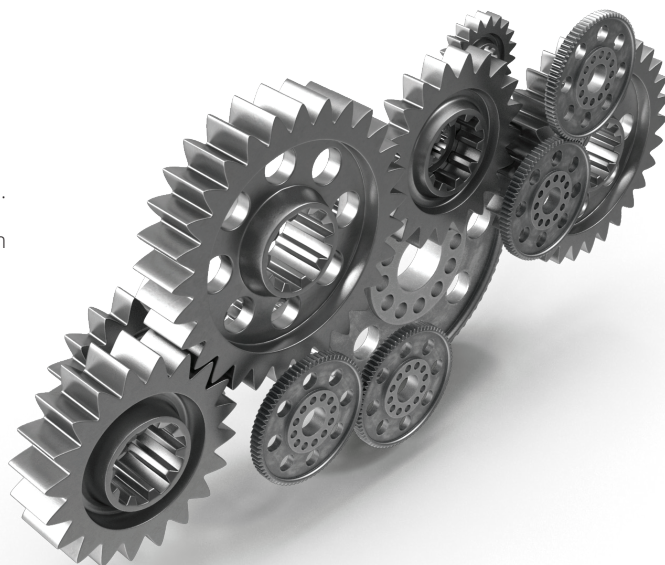

USING DECON HD WILL AID IN ELIMINATING FLUSHING TIME & ASSOCIATED COSTS BY DECONTAMINATING GEARBOXES BETWEEN OIL CHANGES.

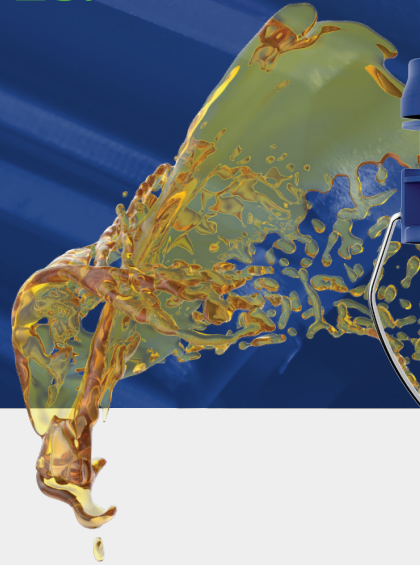

DECON HD is for gearboxes and other applications which utilize viscosity grades of **ISO 150-320**.

OIL SPECIFICATIONS

Test	Method	DECON HD Value
Color	D1500	L 0.5
Appearance	Visual	Bright and Clear
Flash Point (COC)	D92	216°C

HS CODE

3811.29.0000

PACKAGING

Size	Weight	Dimensions
Pail 5 gal (19 L)	41 lbs 19 kg	13 x 13 x 16 (inches) 33 x 33 x 40.7 (cm)
Drum 55 gal (208 L)	462 lbs 210 kg	23 x 23 x 36 (inches) 58.5 x 58.5 x 91.5 (cm)



DECON is warranted to have no compatibility impact on the chemistry of the in-service oil.



Fill4Life™

HELPING YOUR COST CONTROLS MAXIMIZING ASSET LIFE

We're on a journey to deliver value to our customers by maximizing the life of their rotating equipment assets (not only of their fluids) through our **Fill4Life™** program. This program not only extends the life of their capital equipment and their fluids but also aims to support our customers' quality and maintenance programs by minimizing their overall costs and waste. The program leverages the entire Fluitec product and service portfolio.



decon™ HD
with **SOLVANCER®**
A PATENT PENDING TECHNOLOGY