



TEK-BAR 3800XP

Multivariable Transmitter / Flow Computer

Instruction Manual

Document Number: IM-3800XP



www.tek-trol.com

NOTICE

Read this manual before working with the product. For personal and system safety, and for optimum product performance, make sure you thoroughly understand the contents before installing, using, or maintaining this product.

For technical assistance, contact

Customer Support

796 Tek-Drive

Crystal Lake, IL 60014

USA

Tel: +1 847 857 6076

© **COPYRIGHT Tek-Trol LLC 2021**

No part of this publication may be copied or distributed, transmitted, transcribed, stored in a retrieval system, or translated into any human or computer language, in any form or by any means, electronic, mechanical, manual, or otherwise, or disclosed to third parties without the express written permission. The information contained in this manual is subject to change without notice.

Table of Contents

1	Safety Instructions	3
1.1	Intended Use	3
1.2	Certifications	3
1.3	Manufacturer Safety Instructions	3
1.3.1	Disclaimer	3
1.3.2	Product Liability and Warranty	3
1.3.3	Information Concerning the Documentation	3
1.4	Safety Precautions	3
1.5	Packaging, Transportation and Storage	4
1.5.1	Packaging	4
1.5.2	Transportation	4
1.5.3	Storage	4
1.5.4	Nameplate	5
2	Product Description	5
2.1	Introduction	5
2.2	Components of Tek-Bar 3800XP Multivariable Transmitter / Flow Computer	5
2.3	Specifications	6
2.4	Dimensional Drawings	7
2.5	3800XP Models	7
3	Installation	8
3.1	General Instructions	8
3.2	Enclosure Cap Locking Screw	9
3.3	Pole Mounting	9
3.4	Installation for Wet or Dry Gas Flow	10
4	Electrical Connection	10
4.1	Jumper Locations	11
4.2	Bootloader Protect and Bluetooth Disable Jumpers	13
4.3	Battery Backup Memory Jumper (Disable Battery for Storage)	13
4.4	Bluetooth (BT) OTA Update and BT Development Jumpers	14
4.5	Main Board Switch Location (SW1)	14
4.6	Grounding	15
4.7	Wire Gauges	15
4.8	Wiring Instructions	16
4.9	Communication	18
4.9.1	Local Serial Communication Port	18
4.9.2	Bluetooth LE	18
4.9.3	RS232 Mode	18
4.9.4	RS485 Mode	18
4.9.5	Ethernet Port	18
4.9.6	Bluetooth Operation	19
4.9.7	HART Communication	19
5	Operations	20
5.1	Device Set Up Menu	20
5.2	Process Variable Menu	20

5.2.1	Configuration Process Variable Menu.....	21
5.3	Diagnostics or Service Menu	21
5.4	Status Info Menu	21
5.5	Loop Test.....	22
5.6	D/A Trim	23
5.7	Input Calibration.....	25
5.8	Basic Set Up Menu	28
5.9	Device Information Menu	28
5.10	Range Value Menu.....	29
5.11	Detailed Set UP Menu.....	29
5.11.1	System Info Menu	29
5.11.2	System Configure Menu	29
5.11.3	Differential Press	31
5.11.4	Static Pressure Menu	31
5.11.5	RTD Temperature Menu.....	31
6	Menu Tree.....	32
7	Troubleshooting	32

1 Safety Instructions

1.1 Intended Use

Tek-Bar 3800XP Multivariable Transmitter / Flow Computer is designed to use for gas and liquid in harsh environments.

1.2 Certifications

Class 1 Div 1 and Div 2 Approval.

1.3 Manufacturer Safety Instructions

1.3.1 Disclaimer

The manufacturer will not be held accountable for any damage that happens by using its product, including, but not limited to direct, indirect, or incidental and consequential damages.

Any product purchased from the manufacturer is warranted in accordance with the relevant product documentation and our Terms and Conditions of Sale.

The manufacturer has the right to modify the content of this document, including the disclaimer, at any time for any reason without prior notice, and will not be answerable in any way for the possible consequence of such changes.

1.3.2 Product Liability and Warranty

The operator shall bear authority for the suitability of the device for the specific application. The manufacturer accepts no liability for the consequences of misuse by the operator. Wrong installation or operation of the devices (systems) will cause the warranty to be void. The respective Terms and Conditions of Sale, which forms the basis for the sales contract shall also apply.

1.3.3 Information Concerning the Documentation

To prevent any injury to the operator or damage to the device it is essential to read the information in this document and the applicable national standard safety instructions. This operating manual contain all the information that is required in various stages, such as product identification, incoming acceptance and storage, mounting, connection, operation, and commissioning, troubleshooting, maintenance, and disposal.

1.4 Safety Precautions

You must read these instructions carefully prior to installing and commissioning the device. These instructions are an important part of the product and must be kept for future reference. Only by observing these instructions, optimum protection of both personnel and the environment, as well as safe and fault-free operation of the device can be ensured.

For additional information that are not discussed in this manual, contact the manufacturer.

Warnings and Symbols Used

The following safety symbol marks are used in this operation manual and on the instrument.



WARNING

Indicates a potentially hazardous situation which, if not avoided, could result in death or severe injury



CAUTION

Indicates a potentially hazardous situation which, if not avoided, may result in minor or moderate injury. It may also be used to alert against unsafe practices.



NOTE

Indicates that operating the hardware or software in this manner may damage it or lead to system failure.

1.5 Packaging, Transportation and Storage

1.5.1 Packaging

The original package consists of

1. Tek-Bar 3800XP Multivariable Transmitter
2. Documentation



NOTE

Unpack and Check the contents for damages or sign of rough handling. Report damage to the manufacturer immediately. Check the contents against the packing list provided.

1.5.2 Transportation

- Avoid impact shocks to the device and prevent it from getting wet during transportation.
- Verify local safety regulations, directives, and company procedures with respect to hoisting, rigging, and transportation of heavy equipment.
- Transport the product to the installation site using the original manufacturer's packing whenever possible.

1.5.3 Storage

If this product is to be stored for a long period of time before installation, take the following precautions:

- Store your product in the manufacturer's original packing used for shipping.
- Storage location should conform to the following requirements:
 1. Free from rain and water
 2. Free from vibration and impact shock
 3. At room temperature with minimal temperature and humidity variation

- Properties of the instrument can change when stored outdoors.

1.5.4 Nameplate

The nameplate lists the order number and other important information, such as design details and technical data.

i NOTE

Check the device nameplate to ensure that the device is delivered according to your order. Check for the correct supply voltage printed on the nameplate.

2 Product Description

2.1 Introduction

Tek-Trol's Tek-Bar 3800XP (MVT) Multivariable Transmitter / Custody Transfer Flow Computer is designed to provide the highest flexibility. It features a complete suite of measurement calculations and control functions that enable customers to take control of their flow metering requirements. The Tek-Bar 3800XP Multivariable Transmitter is configured for both gas and liquid applications and designed for harsh environments seen in major oil and gas field applications. The device meets both Class 1, Div 1 and Div 2 hazardous safety requirements and meets CSA/ATEX/IECEX. The Tek-Bar 3800XP Multivariable Transmitter (MVT) is designed to provide reliable and accurate Differential Pressure, Static Pressure, and in-Line Temperature Measurements plus flow calculations compatible with the API MPMS 21.1 electronic flow metering standard.

2.2 Components of Tek-Bar 3800XP Multivariable Transmitter / Flow Computer

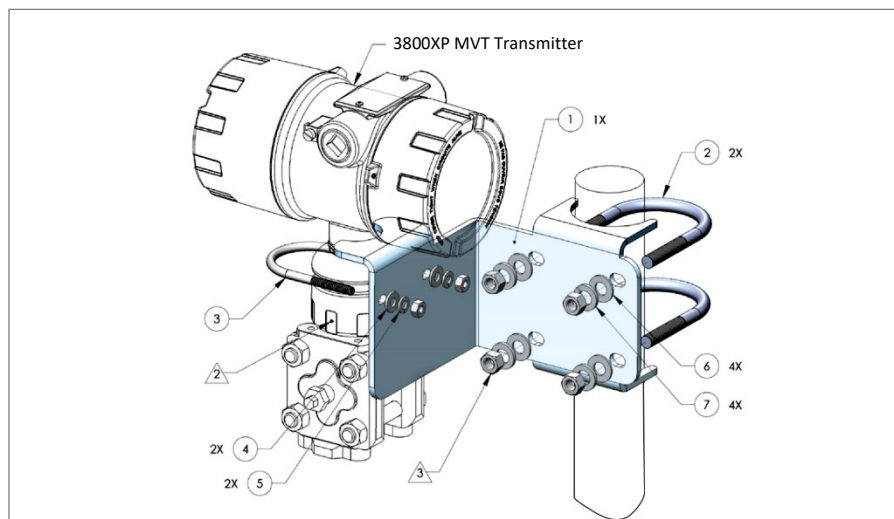

Fig 1: Components of Tek-Bar 3800XP Multivariable Transmitter (MVT)

Mounting Hardware

- | | |
|--|--------------------------|
| 1. Bracket, Pole Mounting | 5. Washer split lock |
| 2. U-bolt 2 ½" ID, 5/16-18 THD with nuts | 6. Washer 3/8 ID flat |
| 3. U-bolt 2" ID, 1/4-20 THD with nuts | 7. Washer split lock 3/8 |
| 4. Washer ¼ ID x 5/8 OD flat | |

2.3 Specifications

Alarm Log Storage	User configurable, defaulting to 200 alarm events
Audit Trails	User configurable, defaulting to 200 audit events
Certifications/Compliance	CSA/C-US Class I, Div 1, Groups B, C, D; ambient temperature range of -40°C to +85°C (-40°F to +185°F), temperature code T6 (-40°C to 75°C) T5 (-40°C to 85°C) EN 61326-1: 2013 (Industrial Criteria); FCC 47 CFR Part 15, Subpart B; ICES 003: 2016; Measurement Canada pending
Data Memory	2 MB Static Random-Access Memory (SRAM)
Description	3800 XP - MVT / Flow Computer for Gas and Liquids
Diagnostic	AGA 10 Speed of Sound (Comparison with GC SOS Prediction)
Differential Meters	(DP, Orifice) AGA 3/ANSI/API 2530-1992 Method 2; AGA 3/ANSI/API 2530-1985; ISO 5167 pt5; DP Cone meters; Averaging Pitot; GOST: Venturi Meters - Steam Flow IF97
Display	128 x 65 backlit LCD display; User programmable scroll list and menus
Enclosure Rating	NEMA 4X/IP67
Energy	AGA 5; GPA 2172; ISO 6976
Ethylene Density Calculation	API 2565 (Ch 11.3.2.1); Ethylene NBS 1045
Input Power	10VDC to 30VDC
Keypad	4 IR sensors through glass key input (hazardous area isolation method).
Linear Meters	(Turbine) AGA 7; AGA 9; AGA 11
Live Density Input	Sarasota liquid density meter, Solartron, UGC, 4-20mA & density meters.
Operating Humidity	0-95% RH, (non-condensing)
Operating Temperature Range	-40° to +185°F (-40° to +85°C)
Processor	32 Bit
Program Memory	4 MB of flash memory
Propylene Density Calculation	API Ch 11.3.3.2
Super Compressibility	(Fpv) AGA 8 Gross-1992; AGA 8 Detail-1992; AGA 8 Short-1988; NX-19; NX-19 Analysis; GERG (ISSN 0178-9414 -2004/8 - European Gas Research Group)
Turbine Meter Linearization	10 Point Frequency/K-factor Table
Volume Correction Factors	Consistent with API 2540/ASTM D1250-80/IP 200; 5/6 A/B; 23/24 A/B; 53/54 A/B; 6/24/54 C; CH 11.1 2004; Note: natural gas liquids (NGL) and liquefied petroleum gases (LPG): OLD 23/24, OLD 53/54; (Note: Table E is new standard to replace the Older version 23/24)

2.4 Dimensional Drawings

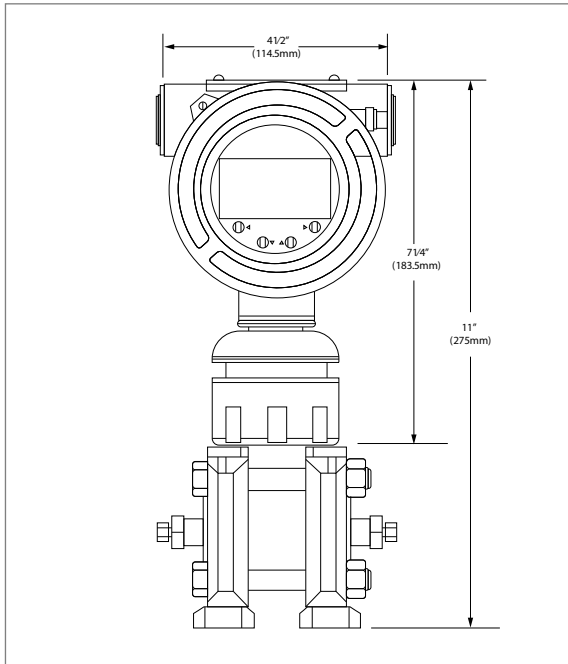

Fig 2: 3800XP MTV Front View

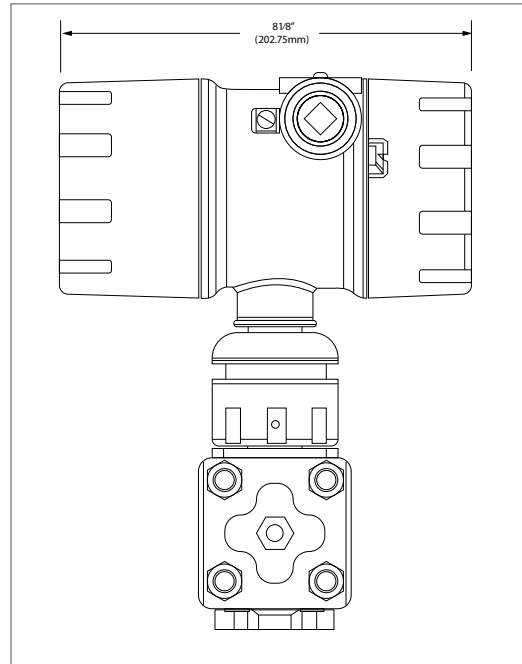

Fig 3: 3800XP MTV Side View

2.5 3800XP Models

3800XP Basic CID1	
3800XP-B-15CS-1	3800XP, Basic, 1500PSIA CS HW, CSA, CID1
3800XP-B-45CS-1	3800XP, Basic, 4500PSIG CS HW, CSA, CID1
3800XP Advanced CID1	
3800XP-A-15CS-1	3800XP, Adv, 1500PSIA CS HW, CSA, CID1
3800XP-A-45CS-1	3800XP, Adv, 4500PSIG CS HW, CSA, CID1
3800XP Basic CID2	
3800XP-B-15CS-4	3800XP, Basic, 1500PSIA CS HW, CSA, CID2
3800XP-B-15SS-4	3800XP, Basic, 1500PSIA SS HW, CSA, CID2
3800XP-B-45CS-4	3800XP, Basic, 4500PSIG CS HW, CSA, CID2
3800XP-B-45SS-4	3800XP, Basic, 4500PSIG SS HW, CSA, CID2
3800XP Advanced CID2	
3800XP-A-15CS-4	3800XP, Adv, 1500PSIA CS HW, CSA, CID2
3800XP-A-15SS-4	3800XP, Adv, 1500PSIA SS HW, CSA, CID2
3800XP-A-45CS-4	3800XP, Adv, 4500PSIG CS HW, CSA, CID2
3800XP-A-45SS-4	3800XP, Adv, 4500PSIG CS HW, CSA, CID2

3 Installation

This section covers instructions on installation and commissioning. Installation of the device must be carried out by trained; qualified specialists authorized to perform such works.



CAUTION

-
- When removing the instrument from hazardous processes, avoid direct contact with the fluid and the MVT wetted parts unless wearing PPE suitable for the environment.
 - All installations must comply with local installation requirements and local electrical code.
-



WARNING

-
- This section offers instructions for installation, wiring, operation, and troubleshooting. The user must read this manual carefully before installation and operation because improper installation may cause incorrect measurement and even damage the Transmitter.
-



NOTE

-
- Improper installation has the potential to cause injury and to damage instrument.
 - Periodically inspect the power cables, transducer cables, cable glands and the enclosure for signs of damage. Inspect transducer installation and mounting hardware for loose connections.
-

3.1 General Instructions

- Installation should be according to ANSI/ISA RP 12.6 and the NEC ANSI/NFPA 70, or Canadian Electrical Code Part 1.
- All wiring requires a minimum of 85°C insulation rating.
- Approved conduit seals should be installed within 18 ¼" (457mm) of the housing.
- Equipment must be installed by qualified personnel.
- Do not disconnect equipment unless power has been turned off or the area is known to be non-hazardous.
- Service connections can be used when the atmosphere is known to be safe and non-hazardous.
- Open enclosure when the location is known to be non-hazardous and remove power from the meter to perform servicing.

3.2 Enclosure Cap Locking Screw

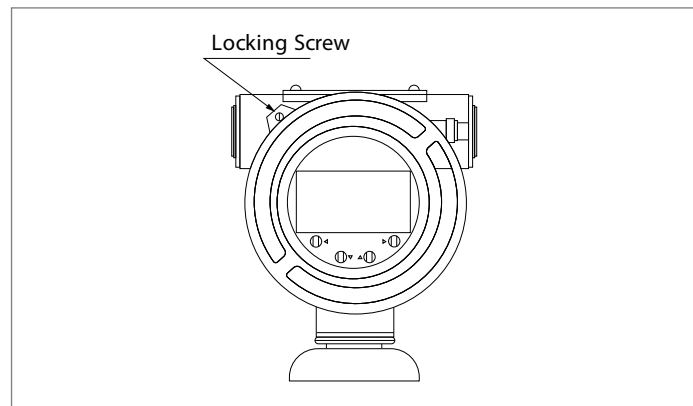

Fig 4: Enclosure Cap Locking Screw

- List of required tools for Enclosure Cap Locking Screw:
 - Flat Head Screwdriver
 - ¼" Wrench or Socket
 - 3/8" Wrench
 - 3/64" Allen Wrench
 - 1.5mm Allen Wrench
 - Strap Wrench

3.3 Pole Mounting



WARNING

-
- Ensure the power is off and the area is non-hazardous before performing this procedure.
 - Installation must be carried out in accordance with local site requirements and regulations.
-

The Tek-Bar 3800XP Multivariable Transmitter can be directly mounted to the orifice fitting or a 2" support pole. Please refer to the following instructions for mounting the enclosure onto a 2" pole and pole mounting (as shown in Figure 1).

- Please align the holes of the single tab mounting bracket with the groove on the enclosure when the enclosure is vertical.
- Facing the enclosure's front, use item 3 (Figure 1) to hold the enclosure against the bracket. Place flat and lock washers over the threads on item 3 (Figure 1) when facing the enclosure's rear and join with nuts.
- Install the two pipe clamps on the pole using the provided hardware.
- Loosen set screw as shown in figure 1 to adjust meter orientation, maximum 180° rotation from starting point.

3.4 Installation for Wet or Dry Gas Flow

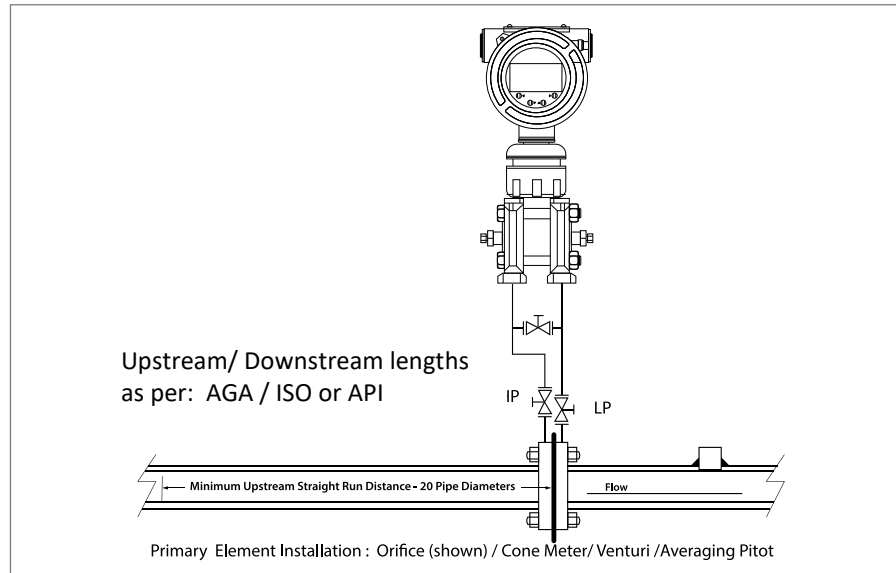

Fig 5: Installation for Wet or Dry Gas Flow

4 Electrical Connection

This section covers all electrical connection requirement. Electrical connection of the device must be carried out by trained; qualified specialists authorized to perform such work by the installation site.



WARNING

- Connect all electrical cables when the power is switched off. If the device does not have switch-off elements, then, overcurrent protection devices, lightning protection and/or energy isolating devices must be provided by the customer.
- The device must be grounded to a spot in accordance with regulations in order to protect personnel against electric shocks.



NOTE

- Improper installation has the potential to cause injury and to damage instrument.
- Periodically inspect the power cables, transducer cables, cable glands and the enclosure for signs of damage. Inspect transducer installation and mounting hardware for loose connections.

4.1 Jumper Locations

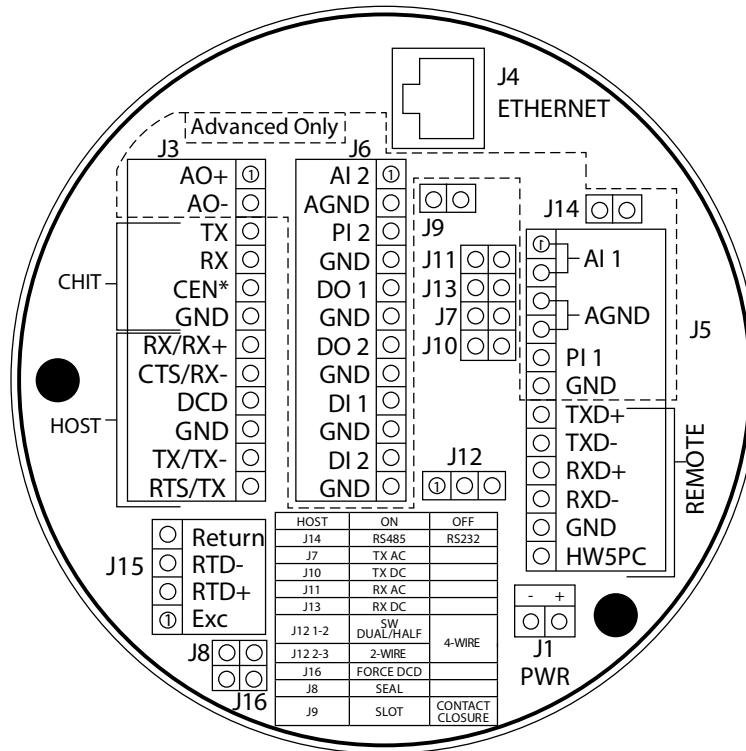

Fig 6: Terminal Board Jumper Locations

Table 1: Terminal Board Jumper Locations

Host	ON	OFF
J14	RS485	RS232
J7	TX AC	
J10	TX DC	
J11	RX AC	
J13	RX DC	
J12 1-2	SW Dual/ Half	4 Wire
J12 2-3	2-Wire	
J16	Force DCD	
J8	Seal	
J9	SLOT	Contact Closure

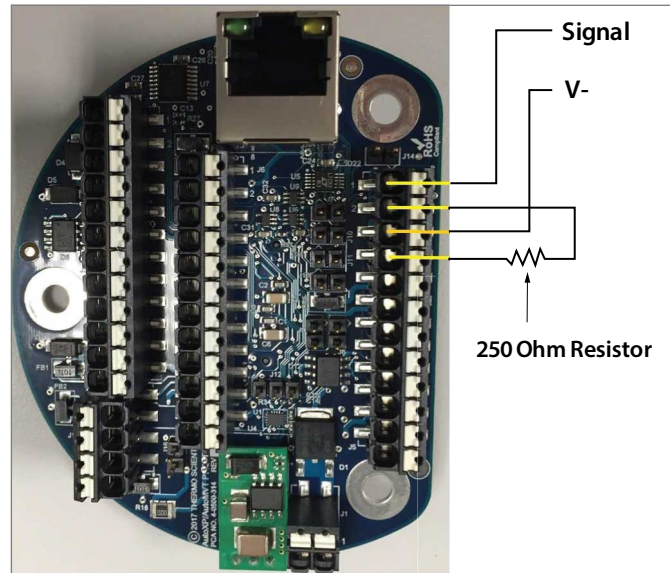

Fig 7: Low Power Transmitter and Local Analog Inputs (4-20mA)

Figure 7 shows typical connections between the low-power transmitter and local analog inputs. Tek-Trol offers an optional 250Ω, high precision, axial lead resistor, P/N 5-1270-250, for converting the 4-20mA current signal to the 1-5V voltage signal, connecting to instrument analog inputs.

Table 2: Typical Switch Configurations

Board	Designator	Description	ON	OFF	Default
HMI	JP2	Bluetooth Development	Development	Auto-Run	OFF
HMI	JP3	Over the Air Bluetooth Update	OTA Mode	Disable	ON
CPU	JP1	Bootloader Protect	Protect	Write	ON
CPU	JP2	Bluetooth Disable	Disable	Enable	OFF
CPU	SW1	Battery Disconnect Switch	Battery Backup	Storage/Cold Start	OFF
Terminal	J7	Host TX AC Termination	Terminated	Unterminated	OFF
Terminal	J8	Sealing Jumper	Sealed	Open	OFF
Terminal	J9	Pulse Mode	Slot	Contact	OFF
Terminal	J10	Host TX DC Termination	Terminated	Unterminated	OFF
Terminal	J11	Host RX AC Termination	Terminated	Unterminated	OFF
Terminal	J12 1-2	Host Duplex Setting	Software Control	4-Wire	OFF
Terminal	J12 2-3		2- Wire		ON
Terminal	J13	Host RX DC Termination	Terminated	Unterminated	OFF
Terminal	J14	Host Mode	RS485	RS232	OFF
Terminal	J16	Force DCD	Forced On	From User	OFF
I/O	JP3	HART Processor Configuration	Not Used	Normal Operation	OFF

4.2 Bootloader Protect and Bluetooth Disable Jumpers

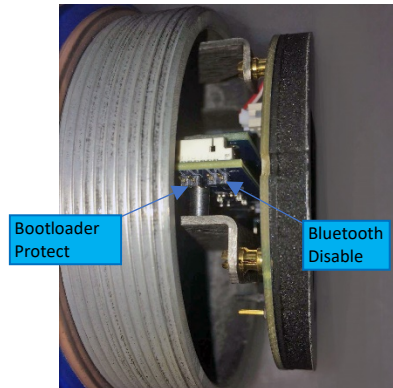

Fig 8: Bootloader Protect and Bluetooth Disable

4.3 Battery Backup Memory Jumper (Disable Battery for Storage)

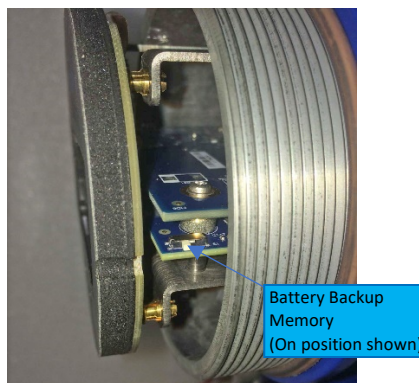

Fig 9: Battery Backup Memory Jumper (ON position)

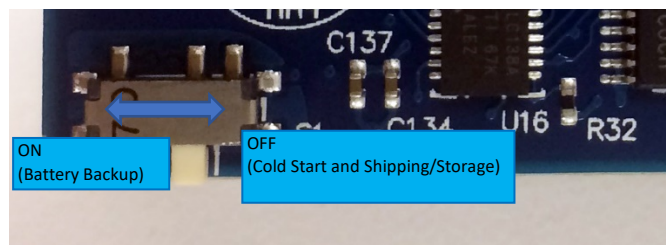

Fig 10: Battery Backup (ON and OFF position)

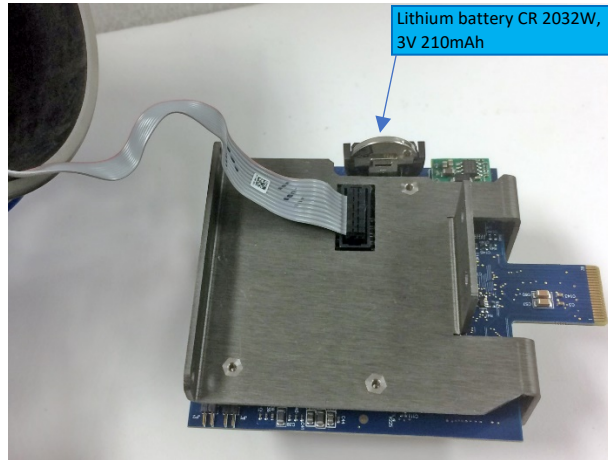

Fig 11: Backup Battery

4.4 Bluetooth (BT) OTA Update and BT Development Jumpers

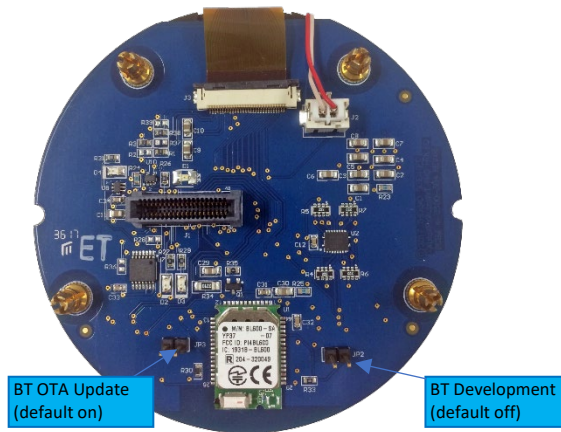

Fig 12: BT OTA Update and BT Development Jumpers

Table 6: Terminal Board

J7	OFF
J8	OFF
J9	OFF
J10	OFF
J11	OFF
J12	ON Position 2-3
J13	OFF
J14	OFF
J16	OFF

Table 3: HMI Board

JP2	OFF
JP3	ON

Table 4: CPU Board

JP1	ON
JP2	OFF

Table 5: I/O Board

JP3	OFF
-----	-----

4.5 Main Board Switch Location (SW1)

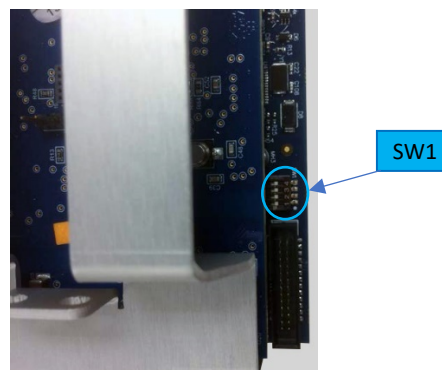

Fig 13: Main Board Switch Location (SW1)

Table 7: Main Board Switch SW1 Default Conditions

SW1	Description	Function	Default
1	Boot loader selection	CPU runs the boot loader upon power-up when the switch is on	OFF
2	Debugger selection	CPU runs the debugger upon power-up when the switch is on. Function not available	OFF
3	Continuous power on	System stays in wake-up mode when the switch is on	OFF
4	System reset	Momentarily switch on to reset the system	OFF

4.6 Grounding

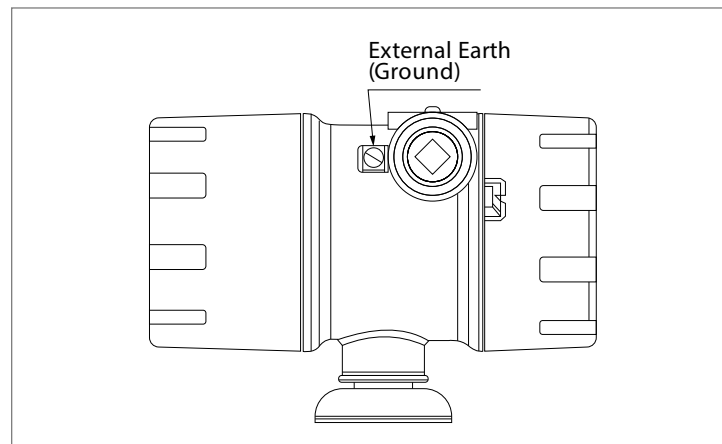

Fig 14: Grounding Connection

- Use copper stranded 12 AWG minimum wire for grounding, as shown in figure 14.
- Connect a grounding wire from enclosure ground lug to earth ground.
- The grounding wire length should be as short as possible.
- Ensure the earth and power ground are connected together, either internally or externally.

4.7 Wire Gauges

Table 8 provides the recommended wire gauges to be used for the Tek-Bar 3800XP Multivariable Transmitter installation:

Table 8: Connection Data

Conductor cross section solid minimum	0.2mm ²
Conductor cross section solid maximum	1.5mm ²
Conductor cross section flexible minimum	0.2mm ²
Conductor cross section flexible maximum	1.5mm ²
Conductor cross section flexible with ferrule, without plastic sleeve minimum	0.2mm ²
Conductor cross section flexible with ferrule, without plastic sleeve maximum	1.5mm ²

Conductor cross section flexible with ferrule, with plastic sleeve minimum	0.2mm ²
Conductor cross section flexible with ferrule, with plastic sleeve maximum	0.75mm ²
Conductor cross section AWG minimum	24/0.2mm ²
Conductor cross section AWG maximum	16/1.3mm ²

4.8 Wiring Instructions

Table 9 provides the wiring instructions used for the Tek-Bar 3800XP Multivariable Transmitter installation:

Table 9: Wiring Instruction

Function	Pin Number	Details
Input Power	J1-1 (+) J1-2 (-)	10 to 30VDC @ 2Watt minimum; Customer supply must include 2A slow blow fuse.
Serial Host port	J3	Configurable: J3-pin 7-12 (RS232); J3-pin 7-10, 11-12 (RS485 4-wire); J3-pin 7-10, 11-12 (RS485 2-wire; Jumped TX+/RX+, TX-/RX-) recommended 26 AWG; Twisted pair for RS485
Local serial port or CHIT	J3	J3-pin 3-6
Ethernet	J4	CAT 5 shield cable
RTD	J15	J15-pin 1-4; 4-wire J15-pin 1-3; 3-wire; with pin 3 and 4 jumped
AO (Analog output)	J3-1 and 2	4-20mA; loop power customer supply; minimum 10VDC, maximum 30VDC

<p>DO (Digital Out)</p>	<p>J6-4-6</p>	<p>DO1-pin 5-6; open drain; customer supply power DO2-pin 7-8; open drain; customer supply power</p> <p>The diagram shows two pin headers for DO1 and DO2. The first header has pins DO 1, GND, DO 2, and GND. The second header has pins DO1/DO2* and GND. Two circuit diagrams are provided: the top one shows a 'Discrete Output' from a 'Customer Device' connected to 'Customer Power' (+) and 'Output Return' (-), with an 'Input Signal' line to the DO1/DO2* pin; the bottom one shows an 'Open Drain' output from 'Customer Equipment' connected to 'Customer Power' (+) through a 'Pull up resistor (10K Typical)' and 'Output Return' (-), with an 'Output Signal' line to the DO1/DO2* pin.</p>
<p>AI (analog input)</p>	<p>J5; J6</p>	<p>AI1, J5-pin 1-4 (power/signal+; signal-/ground) AI2, J6-pin 1-2 (signal+; ground)</p> <p>The diagram shows two pin headers for AI1 and AI2. The AI1 header has pins 1, AI 1, AGND, and 2. The AI2 header has pins AI 2 and AGND. A circuit diagram for AI1 shows a 'Low Power Transmitter' connected to 'Customer Power' (+) and 'Transmitter Ground' (-), with a 'Transmitter Signal' line to the AI pin and a 'Transmitter Shield' connected to the AGND pin.</p>
<p>PI (pulse input)</p>	<p>J5; J6</p>	<p>PI1, J5-pin 5-6 (slot sensor 5KHz; contact closure 300Hz) PI2, J6-pin 3-4</p> <p>The diagram shows two pin headers for PI1 and PI2. The PI1 header has pins PI 1 and GND. The PI2 header has pins PI 2 and GND. Two circuit diagrams are provided: the top one shows a 'Pulse Input' from a 'Customer Device' connected to 'Input Signal' and 'Signal Return' lines, with the 'Signal Return' line connected to the GND pin; the bottom one shows a 'Pulse Input' from 'Customer Equipment' connected to 'Input Signal ± 15V Max' and 'Signal Return' lines, with the 'Signal Return' line connected to the GND pin.</p>

4.9 Communication

4.9.1 Local Serial Communication Port

The terminal board provides one RS232 compatible local communication port (CHIT) for calibration and configuration of the unit using a laptop and configuration software.

Table 10: Cable assemblies for CHIT connector

Assembly P/N	Description
3-0446-090	DB9S connector with 15-ft cable for use with the six-position connector
3-0446-090B	DB9S connector with 25-ft cable for use with the six-position connector

4.9.2 Bluetooth LE

Bluetooth Low Energy connection is available. A Bluetooth Low Energy Dongle is required to operate this function (Contact Tek-Trol for this device).

4.9.3 RS232 Mode

- If not used internally, the communication port can interface to any RS232 compatible customer device, such as a radio.
- Do not exceed +15VDC on any of the communication lines.
- Host communication port RS232 connections are identified in the following Table 11.

Table 11: Host communication port RS232 connections

Signal	J3 on Terminal Board
RX (Receive)	J3-7
CTS (Clear to Send)	J3-8
TX (Transmit)	J3-11
RTS (Request to Send)	J3-12
DCD (Data Carrier Detect)	J3-9
GND (Ground)	J3-10

*Note:

For RS232 mode, do not install jumper J14.

For RS232 mode without DCD signal, install jumper J16.

4.9.4 RS485 Mode

- The host communication port supports RS485 communication.
- To use RS485 mode, jumpers J14 and J16 must be installed.
- Select RS485 2-wire mode by installing a jumper on J12 pins 2-3.
- Remove the jumper for 4-wire mode.

4.9.5 Ethernet Port

Jumper J4 on the main board is a 10M/100M Ethernet port supports standard TCP/IP protocol.

4.9.6 Bluetooth Operation

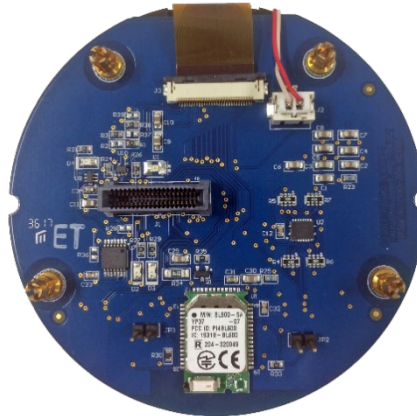

Fig 15: Bluetooth Operation JP2 and JP3

Table 12: Bluetooth Pin Description

JP2	OFF	Factory Default - Self Run Mode
	ON	Bluetooth Disable (Must Power Cycle after Jumper set)
JP3	ON	OTA (Over the Air Mode) - Factory Default Mode
	OFF	Manufacturing Use Only

4.9.7 HART Communication

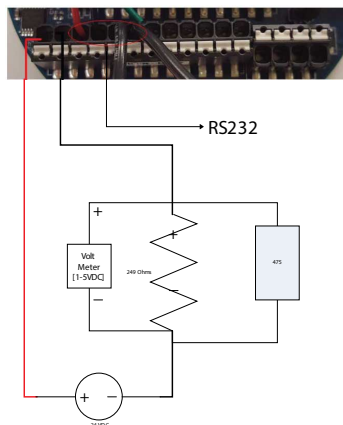

Fig 16: HART connection for the 4-20mA current loop

- The 4 to 20mA output represents the digital Primary Variable [PV].
- The primary variable can be setup for Differential Pressure, Static Pressure or Line Temperature, for Tek-Bar 3800XP Multivariable Transmitter.
- By default, the 4-20mA output is set for Differential Pressure with a Range of 0 to 100" H₂O.
- This can be modified to suit customer requirements using a HART master such as a 475 HHT or AMS PC based system.
- The 4-20mA output can have a damping value applied to smooth out any sudden changes on the current loop, if required.
- Damping is entered as an integer representing seconds.

- The output will then reply to a step change and the output will achieve 66% of final value after the number of seconds entered.
- The current loop for the Tek-Bar 3800XP Multivariable Transmitter has an operating range of 3.8 to 20.8mA. This allows for an over and under-range of the Primary Variable on the current loop.

5 Operations

This section describes the menu structure. The menu structure is based on the LCD display of the HHT Online Menu.

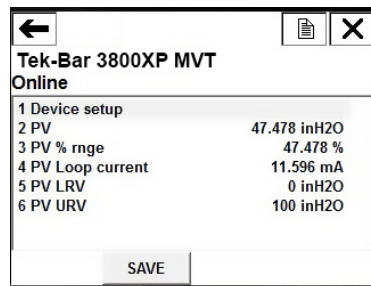

Fig 17: Initial Online Menu

5.1 Device Set Up Menu



The Device Set UP Menu allows access to the configuration, live information, and diagnostics for Tek-Bar 3800XP Multivariable Transmitter.

5.2 Process Variable Menu

The Process Variables Menu displays the Primary Variable [PV], Secondary Variable [SV], Tertiary Variable [TV] and Quaternary Variable [QV] supported by Tek-Bar 3800XP Multivariable Transmitter.

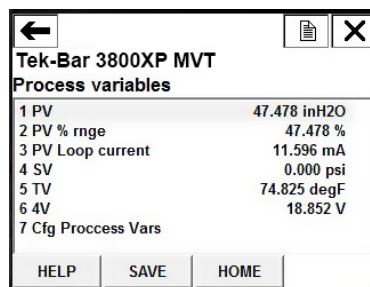

5.2.1 Configuration Process Variable Menu

The Configuration Process Variable Menu is used to configure or allocate each of the process variables to items within the Tek-Bar 3800XP Multivariable Transmitter.

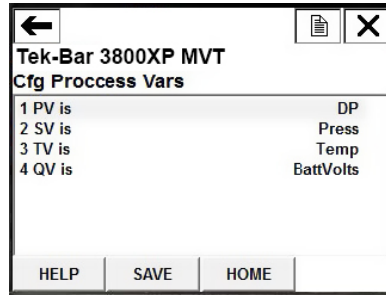

Each process variable PV, SV, TV, or QV can be allocated to one of the following parameters:

- Differential Pressure
- Static Pressure
- RTD Temperature
- Battery Voltage

5.3 Diagnostics or Service Menu

The Diagnostics or Service Menu is used to verify the status of the Tek-Bar 3800XP Multivariable Transmitter. It also performs calibration or verification of the analog inputs and 4 to 20mA output.

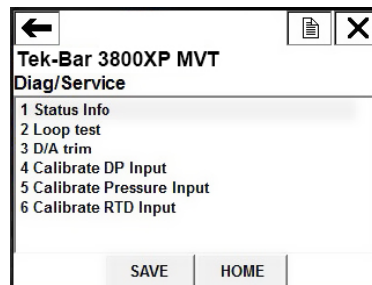

5.4 Status Info Menu

Status Info Menu allows the user to monitor the alarm status of DP, SP, RTD Temperature.

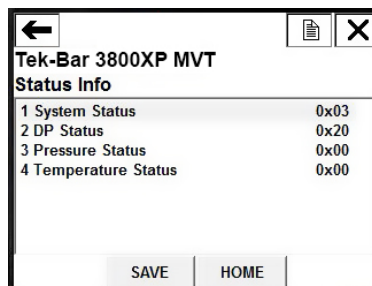

5.5 Loop Test

- Loop Test is used to verify the 4-20mA current output of the Tek-Bar 3800XP Multivariable Transmitter.
- The associated method automatically run and can supply any required mA value from between 4 and 20mA, therefore the current loop can be verified when connecting to a host device.
- After selection of the required input for calibration a warning is provided to remove the Tek-Bar 3800XP Multivariable Transmitter output from any automatic control.



- Select required output to force onto the 4-20mA loop:

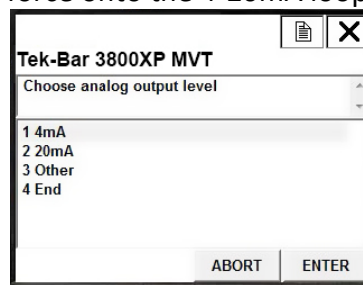

- Enter required value to output.

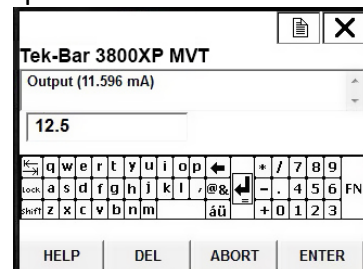

- Required output is fixed to the 4 to 20mA current loop.

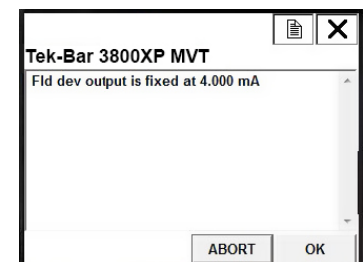

- Press OK to return to second step or press abort to exit the Loop Test.
- Current Loop Test is complete.

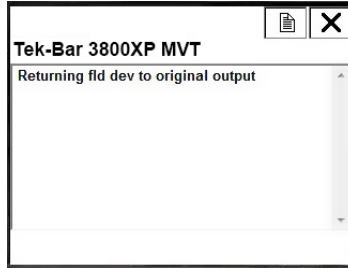

5.6 D/A Trim

- D/A Trim is used to calibrate the 4 to 20mA output of the Tek-Bar 3800XP Multivariable Transmitter.
- The associated method automatically run and request a user to connect a reference meter to measure the current on the 4 to 20mA current loop.
- Points are calibrated at 4mA and 20mA as follows:
 1. After selection of D/A Trim, a warning is provided to remove the Tek-Bar 3800XP Multivariable Transmitter output from any automatic control.



2. The user is requested to connect a reference meter for Loop calibration.

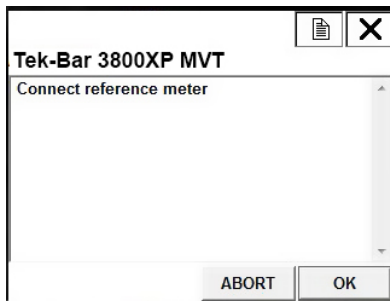

3. 4mA is fixed to the current Loop.

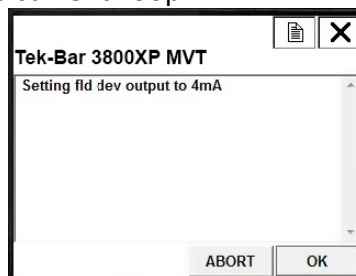

4. User enters actual measured value.

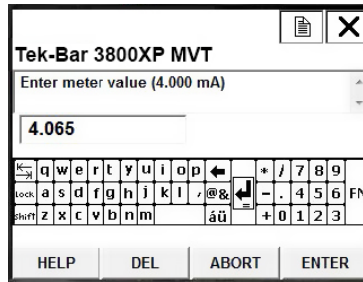

5. Tek-Bar 3800XP Multivariable Transmitter will modify the output to provide 4mA. If the output goes to 4mA, proceed to step 6 below. If the output is not 4mA, go back to step 4.

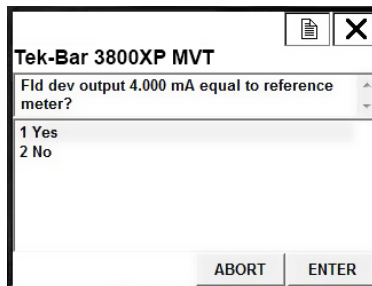

6. 20mA is fixed to the current loop.



7. User enters actual measured value.

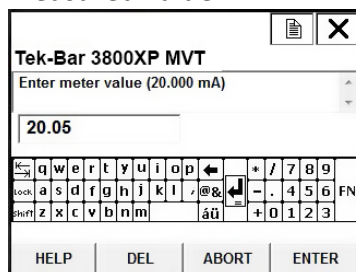

8. Tek-Bar 3800XP Multivariable Transmitter will modify the output to provide 20mA. If the output goes to 20mA, proceed to step 9 below. If the output is not 20mA, go back to step 7.

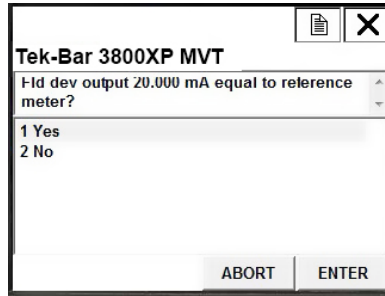

9. D/A Trim is complete. The 4-20mA output will be returned to its original value.

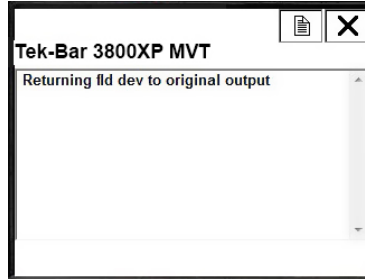

5.7 Input Calibration

Differential Pressure, Static Pressure and RTD Temperature inputs can be calibrated from the Diagnostics or Service Menu.

Calibration Method:

1. After selection of the required input for calibration, a warning is provided to remove the Tek-Bar 3800XP Multivariable Transmitter output from any automatic control.

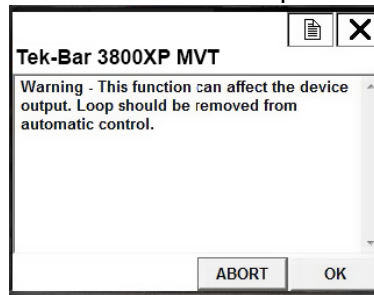

2. Select the required number of calibration points.

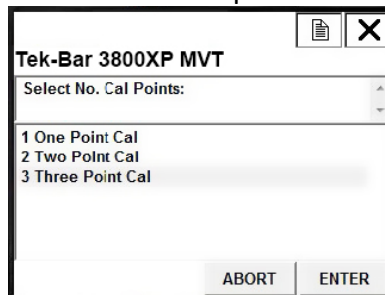

3. Supply minimum input to RTD.



4. Display live object update of actual input value.
5. Press ENTER when value is stable.

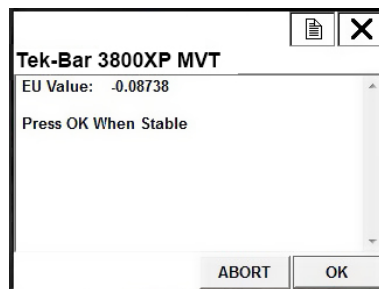

6. Enter actual value supplied to input.

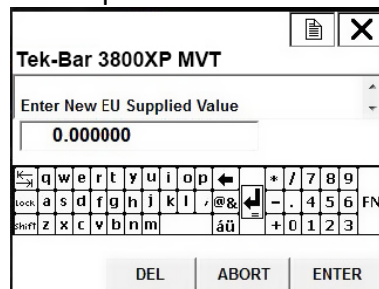

7. If a 1-point calibration is required, go to step 17 below.
8. If a 2-point calibration is required, go to step 13 below. For a 3-point calibration, supply a mid-range value to the input.

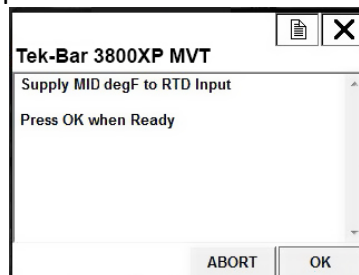

- 9. Display live updates of actual input value.
- 10. Press ENTER when value is stable.

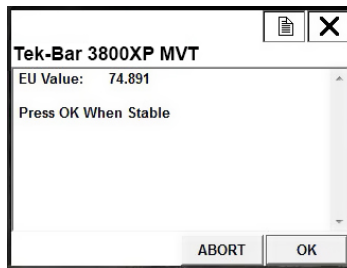

- 11. Enter actual Mid value supplied to the input.

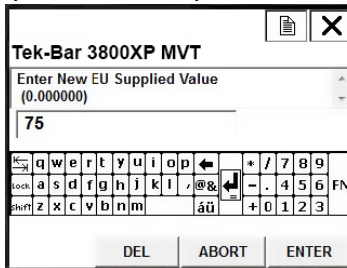

- 12. Supply a full-scale/Max value to the input.

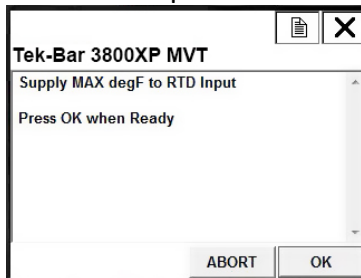

- 13. Display live updates of actual input value.
- 14. Press ENTER when value is stable.

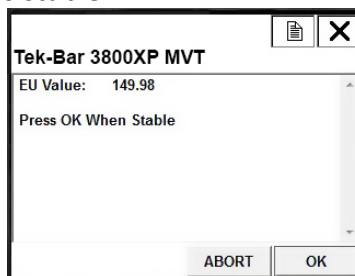

- 15. Enter actual Max value.



16. Update Calibration.

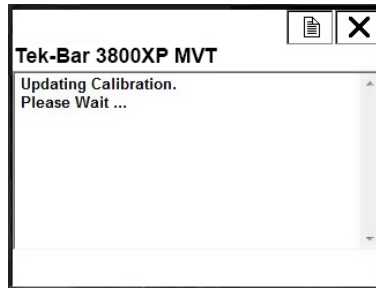

17. Calibration is complete and user can return to the Diagnostics or Service Menu.



5.8 Basic Set Up Menu

The Basic Setup Menu is used to configure standard HART variables such as Tag, P Units and Damping. The sub menu allows device information and PV range values to be configured.

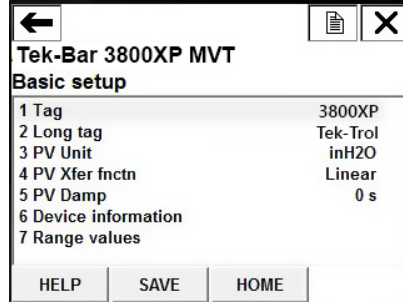

5.9 Device Information Menu

Device Information Menu allows a user to configure or view the HART variables such as Distributor, Model, Loop Current Mode, Poll Address, Device ID, Configure Change Count, Tag, Long Tag, Date, Write Protect Mode, Descriptor, Message, Final Assembly Number, Revision Info.

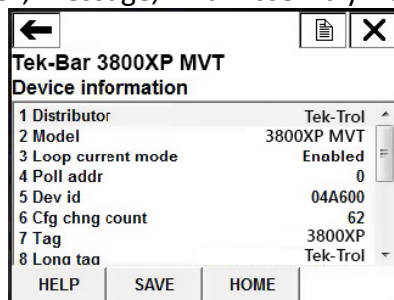

5.10 Range Value Menu

Range Values Menu allows a user to configure PV lower and upper range value. These values are effectively the 4-20mA Zero and Full-Scale values.

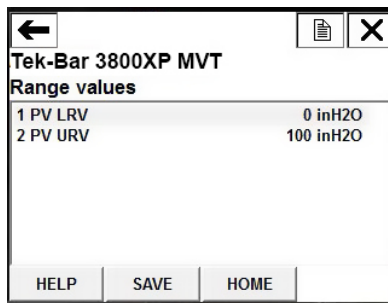

5.11 Detailed Set UP Menu

The Detailed Setup Menu is used to configure or view the Tek-Bar 3800XP specific variables.

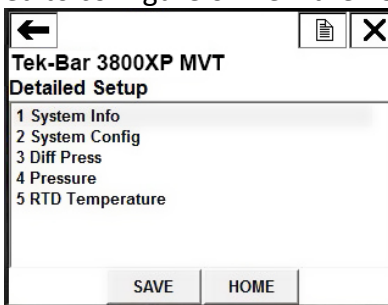

5.11.1 System Info Menu

System Info Menu provides general information about Tek-Bar 3800XP Multivariable Transmitter such as, Start Date, Start Time, RTU Version, Thermo ID, And Different Inputs and Outputs.

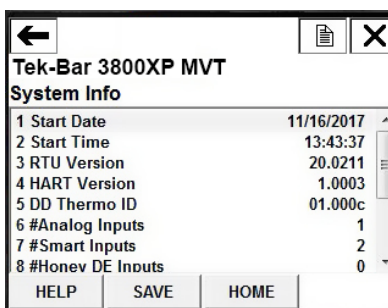

5.11.2 System Configure Menu

System Configure Menu allows a user to configure the RTC, Display and Input Units Selection for the Tek-Bar 3800XP Multivariable Transmitter. This menu also allows various reset commands.

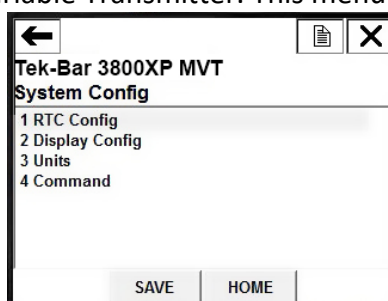

5.11.2.1 RTC Configure Menu

RTC Configure Menu is used to display or configure the RTC time and date within the Tek-Bar 3800XP Multivariable Transmitter. The date format is always in mm/dd/yyyy format.

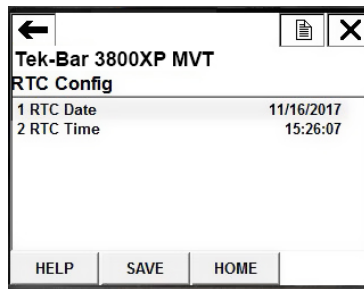

5.11.2.2 Display Configure Menu

Display Configure Menu is used to configure the scroll time, contrast, and date format of display.



5.11.2.3 Unit Menu

Units Menu is used to display or configure the units for the DP, SP and RTD Temperature units.

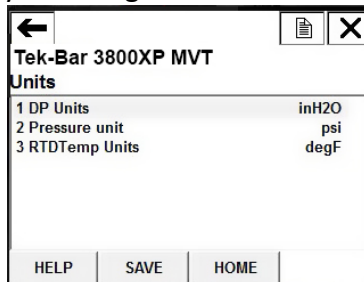

5.11.2.4 Command Menu

Command Menu is used to access the reset method for the Tek-Bar 3800XP Multivariable Transmitter.

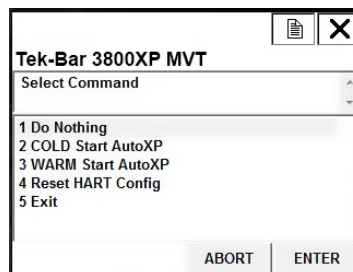

5.11.3 Differential Press

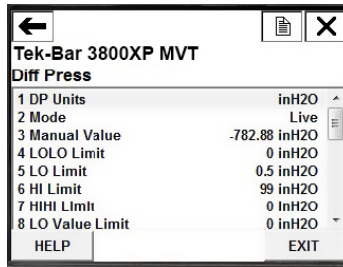

5.11.4 Static Pressure Menu

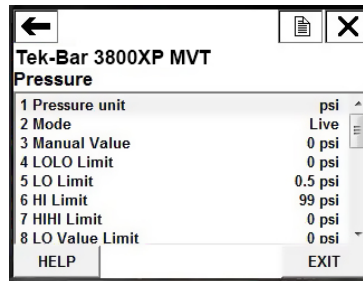

5.11.5 RTD Temperature Menu

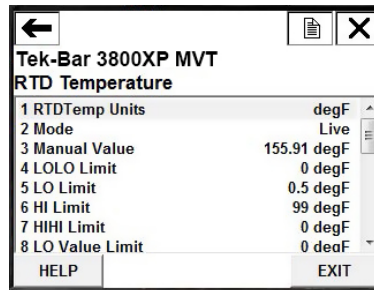

6 Menu Tree

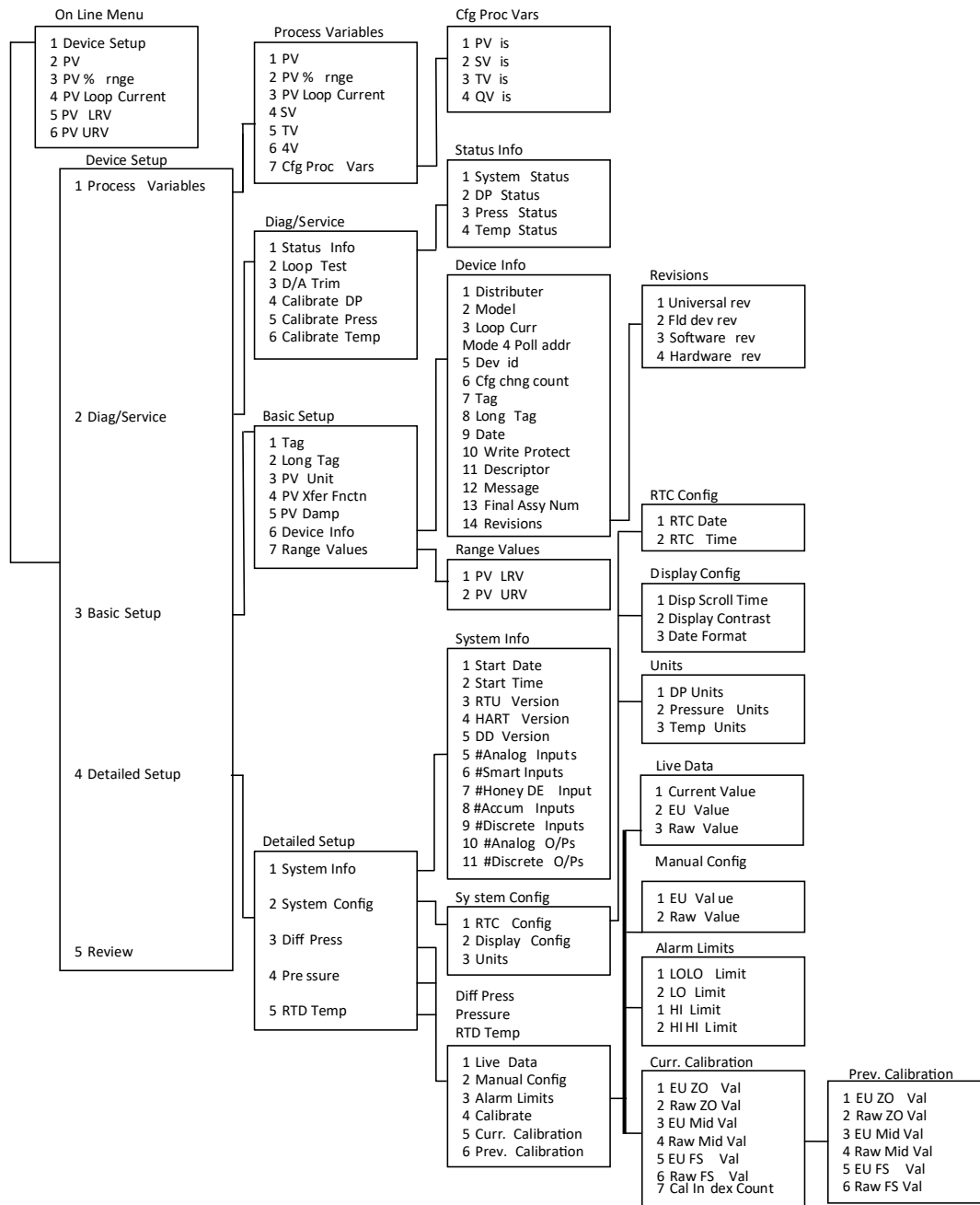

7 Troubleshooting

Symptom	Solution
Instrument is not working and/or LCD not displaying	<ul style="list-style-type: none"> • Press wakeup button on the display. • Check input voltage polarity. • Check input voltage level to be 10 to 30volts. • Replace Terminal board



TEKMATION LLC reserves the right to change the designs and/or materials of its products without notice. The contents of this publication are the property of TEKMATON and cannot be reproduced by any other party without written permission. All rights reserved. Copyright © 2020 TEKMATON LLC
DOC:TEK/PO/WW/210225/3900XP/100
TEKMATION LLC



www.tek-trol.com

Tek-Trol LLC

796 Tek Drive Crystal Lake, IL 60014, USA
Sales: +1 847-857-6076

Tek-DPro Flow Solutions

PO Box 121 Windsor, Colorado 80550,
USA
Sales: +1 847-857-6076

Tek-Trol Solutions BV

Florijnstraat 18, 4879 AH Etten-Leur,
Netherlands
Sales: +31 76-2031908

Tek-Trol Middle East FZE

SAIF Zone, Y1-067, PO BOX No.
21125, Sharjah, UAE
Sales: +971-6526-8344

Support: +1 847-857-6076

Email: tektrol@tek-trol.com

www.tek-trol.com

Tek-Trol is a fully owned subsidiary of TEKMATON LLC. We offer our customers a comprehensive range of products and solutions for process, power and oil & gas industries. Tek-Trol provides process measurement and control products for Flow, Level, Temperature & Pressure Measurement, Control Valves & Analyzer systems. We are present in 15 locations globally and are known for our knowledge, innovative solutions, reliable products and global presence.

Flow | Level | Temperature | Pressure | Valves | Analyzers | Accessories | TekValSys