

Sage Paramount™ User Manual

Sage Model 401 and 402 Thermal Mass Flow Meters

This document is the user manual for Sage Paramount™ Models 401 (integral) and 402 (remote) thermal mass flow meters. In addition to the typical sections of a user manual, contained within is a quick start guide and illustrations.



*Choose Wisely.
Sage Flow Meters*

SAGE METERING, INC.

8 Harris Court, Bldg. D Monterey, CA 93940

1-866-677-SAGE (7243)

1-831-655-4965

www.SageMetering.com

Revision History

Revision	Date	Revision Description
1.0	8/26/2019	Paramount Manual – Initial Document
8.0	2/24/2021	Paramount Manual – Class I Div 1 and other changes
9.0	11/12/2021	Paramount Manual – Insertion of Appendix A (Mechanical Drawings)

Table of Contents

Revision History	2
Quick Start Guide	5
Welcome	8
SECTION A: Getting Started	9
Unpacking Your Sage Meter	10
Maintenance	10
Calibration.....	10
Installation and Mounting.....	11
EN60079-14 Standard for Electrical Installations	11
Locating Proper Wiring Diagram.....	11
Insertion Flow Meter Application	12
Flow Profile and Installation Considerations	12
Sage Valve Assembly Operation	12
Flow Conditioning and Straight Run	12
Compression Fitting Operation.....	13
Captive Flow Conditioners	14
Probe Insertion Guideline	15
1/2-Inch Probe Diameter Installation	16
3/4-Inch Probe Diameter Installation	17
Recommended Probe Lengths Data Sheet	18
Inline Flow Meter Application.....	19
SECTION B: Styles and Features	20
Principle of Operation of the Thermal Mass Flow Meter	21
Approvals	22
Class I Div 2 Hazardous Location ¹	22
Class I Div 1 Hazardous Location ¹	23
Paramount Remote Sensor CID1 Approved LABEL COMPLIANCE	24
CID1 THREAD REQUIREMENTS.....	25

DIAGRAM: CID1 THREAD CALLOUTS..... 26

SECTION C: Diagnostics 32

 Paramount Diagnostics 33

 RMA (Return Merchandise Authorization) 36

APPENDIX A: Mechanical 37

 A1: EXTERNAL DIMENSIONS FLOW METER 37

 A2: EXTERNAL DIMENSIONS SENSOR PROBE LENGTH..... 37

APPENDIX B: Electrical Wiring..... 39

 B1: 24VDC Powered—15VDC or 24VDC 4–20mA—15VDC Pulse Output..... 40

 B2: 24VDC Powered—15VDC or 24VDC 4–20mA—mA Pulse Output 41

 B3: 24VDC Externally Powered—12VDC–24VDC 4–20mA—12VDC–4VDC 42

 B4: 24VDC Externally Powered—12VDC–24VDC 4–20mA—mA Pulse 43

 B5: 110VAC—24VDC 4–20mA—24VDC Pulse Output 44

 B6: 110VAC—24VDC 4–20mA—mA Pulse Output..... 45

 B7: Externally Powered Isolated—12–24VDC—HART Enabled—Loop Powered 46

 B8: 24VDC Isolated—HART Enabled—Loop Powered 47

 B9: 110 VACS Isolated—HART Enabled—Loop Powered..... 48

 B10: Remote Cable Wiring Connections 49

 B11: REMOTE SENSOR OPTION HARDWARE INSTALLATION GUIDE..... 50



APPENDIX C: Modbus, BACnet, and Hart..... 51



 C1: Modbus Register Map..... 52



 C2: BACnet PICs..... 54

 C3: HART Fast Keys..... 57

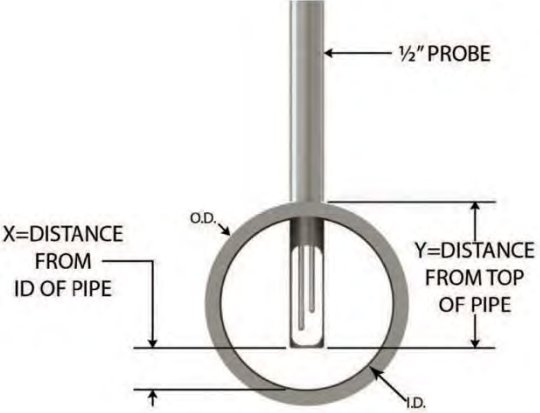
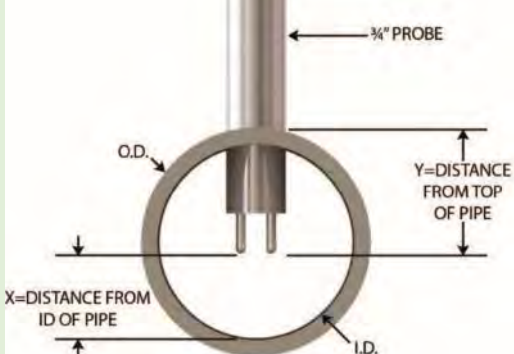
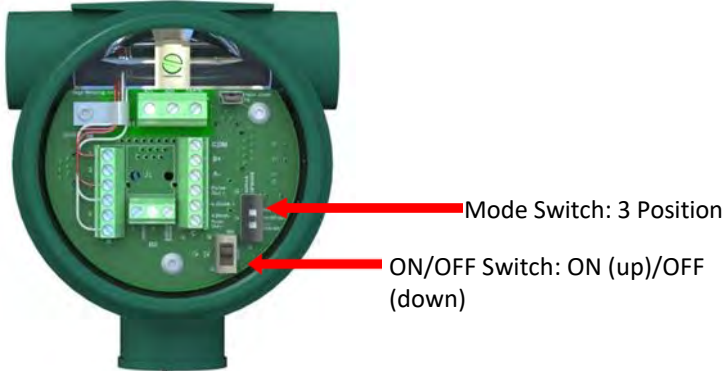
Quick Start Guide

Step	Description	P & ID Diagram																							
<p>1</p>	<p>PACKAGE CONTENTS:</p> <p>Ascertain that your order has all equipment and accessories; refer to the packing list.</p>																								
<p>2</p>	<p>INSERTION-TYPE FLOW METER DIAMETER CHECK:</p> <p>Check that the internal pipe diameter (ID) matches the pipe ID shown on the Sage Calibration Certificate.</p>																								
<p>3</p>	<p>FLOW DIRECTION:</p> <p>Verify the straight-run requirements based upon pipe ID and meter type style.</p>	<p>IMPORTANCE OF FLOW CONDITIONING Recommended Pipe Diameters Upstream</p> <table border="1"> <thead> <tr> <th rowspan="2">DISTURBANCE</th> <th>Without Flow Conditioning</th> <th>With Flow Conditioning¹</th> </tr> <tr> <th>Minimum Industry Recommendation</th> <th>Sage Recommendation</th> </tr> </thead> <tbody> <tr> <td>One 90° Elbow</td> <td>25</td> <td>3</td> </tr> <tr> <td>Two 90° Elbows in the Same Plane</td> <td>36</td> <td>5</td> </tr> <tr> <td>Two 90° Elbows in Different Planes</td> <td>62</td> <td>9</td> </tr> <tr> <td>4:1 Area Reduction</td> <td>18</td> <td>3</td> </tr> <tr> <td>4:1 Area Expansion</td> <td>84</td> <td>10</td> </tr> <tr> <td>Multiple Disturbance</td> <td>TBD</td> <td>TBD</td> </tr> </tbody> </table> <p>¹ This column applies to in-line flow meters, which come standard with built-in flow conditioners, as well as insertion meters, when installed with upstream Captive Flow Conditioners.</p>	DISTURBANCE	Without Flow Conditioning	With Flow Conditioning ¹	Minimum Industry Recommendation	Sage Recommendation	One 90° Elbow	25	3	Two 90° Elbows in the Same Plane	36	5	Two 90° Elbows in Different Planes	62	9	4:1 Area Reduction	18	3	4:1 Area Expansion	84	10	Multiple Disturbance	TBD	TBD
DISTURBANCE	Without Flow Conditioning	With Flow Conditioning ¹																							
	Minimum Industry Recommendation	Sage Recommendation																							
One 90° Elbow	25	3																							
Two 90° Elbows in the Same Plane	36	5																							
Two 90° Elbows in Different Planes	62	9																							
4:1 Area Reduction	18	3																							
4:1 Area Expansion	84	10																							
Multiple Disturbance	TBD	TBD																							

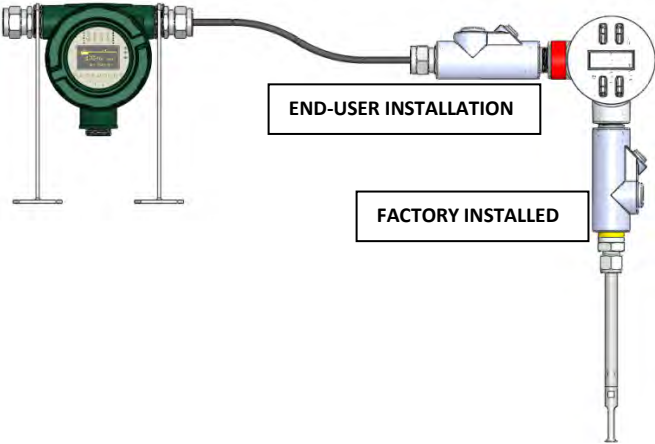
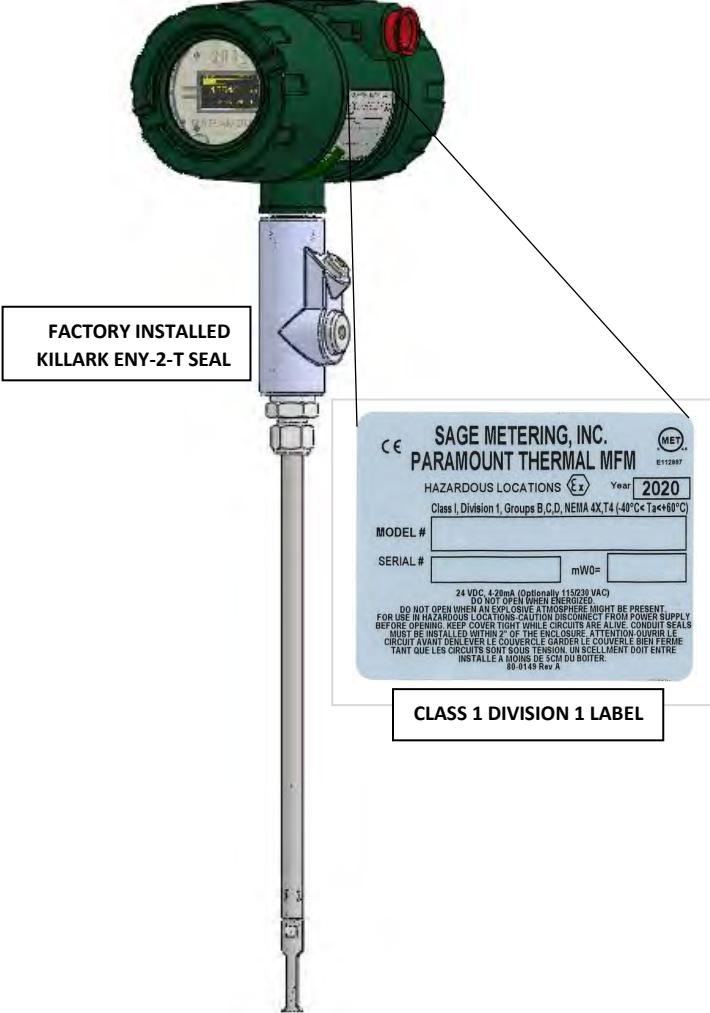
<p>4a</p>	<p>VERIFY CORRECT PROBE DEPTH SETTING:</p> <p>1/2-Inch Probe</p> <p>See 1/2" Probe Diameter Installation (page 16).</p>	
<p>4b</p>	<p>VERIFY CORRECT PROBE DEPTH SETTING:</p> <p>3/4-Inch Probe</p> <p>See 3/4" Probe Diameter Installation (page 17).</p>	
<p>5</p>	<p>POWER SOURCE and 4–20mA WIRING:</p> <p>Remove the flow meter back cover and verify the wiring connectivity; see Appendix B (page 39).</p> <p>POWER SWITCH "ON": Set the power switch in the "up" position.</p>	 <p>Mode Switch: 3 Position</p> <p>ON/OFF Switch: ON (up)/OFF (down)</p>
<p>6</p>	<p>REMOTE-SENSOR WIRING:</p> <p>Remove the flow meter back cover and remote-sensor probe front cover and verify wiring connectivity; see B10 on page 49.</p> <p>POWER SWITCH "ON": Set the power switch in the "up" position.</p>	

<p>7</p>	<p>REMOTE-SENSOR CID1 APPROVAL (HARDWARE):</p> <p>To maintain CID1 Approval category field applications, a Killark seal hardware must be installed. see pages 27–31.</p>	
<p>8</p>	<p>PARAMOUNT METER CID1 APPROVAL (HARDWARE):</p> <p>To maintain CID1 Approval category field applications, a Killark seal hardware must be installed. see pages 27–31.</p>	 <p>FACTORY INSTALLED KILLARK ENY-2-T SEAL</p> <p>CLASS 1 DIVISION 1 LABEL</p> <p>SAGE METERING, INC. PARAMOUNT THERMAL MFM HAZARDOUS LOCATIONS  Year 2020 Class 1, Division 1, Groups B,C,D, NEMA 4X,T4 (-40°C< Ta<+60°C) MODEL # _____ SERIAL # _____ mWG= _____ 24 VDC, 4.20mA (Optionally 115/230 VAC) DO NOT OPEN WHEN ENERGIZED. DO NOT OPEN WHEN AN EXPLOSIVE ATMOSPHERE MIGHT BE PRESENT FOR USE IN HAZARDOUS LOCATIONS CAUTION DISCONNECT FROM POWER SUPPLY BEFORE OPENING. KEEP COVER TIGHT WHILE CIRCUITS ARE ALIVE. COUVERTS SEALS MUST BE INSTALLED WITHIN 2" OF THE ENCL. OSGING. ATTENTION COUVERTS CIRCUIT AVANT D'ENLEVER LE COUVERT. GARDER LE COUVERT BIEN FERMÉ TANT QUE LES CIRCUITS SONT SOUS TENSION. UN SCELLLEMENT DOIT ÊTRE INSTALLÉ À MOINS DE 5CM DU BOITIER. 99-0149 Rev. A</p>

Welcome

We are pleased that you have chosen a Sage Metering mass flow meter for your industry requirement. You'll be satisfied with the performance, operation, and design of our highly precise, NIST-traceable thermal gas mass flow meter.

Sage Paramount™ is the latest addition to our family of high-performance thermal mass flow meters. Your new meter is supplied with a complimentary copy of the SageCom™ Validation and Configuration Software. The meter features a bright graphical display of flow rate, total and temperature, a robust industrial enclosure, and easy to access power and output terminals. Sage Paramount has a dual-compartment windowed enclosure featuring a very high contrast photo-emissive OLED display.

The rear compartment, separated from the electronics, has large, easy to access and well-marked terminals, for ease of customer wiring, including an on/off power switch and USB and cable that easily connect to a PC to start the SageCom software. The meter is powered by 24 VDC (optionally 115/230 VAC), and is extremely energy efficient with a power dissipation under 2.5 watts (e.g., under 100 mA at 24 VDC for the DC version).

Sage Paramount has recently been awarded a Division 1 approval status in addition to its prior Division 2 approval. You now have the choice to use the flow meter either in a Division 2 or Division 1 environment. **However, there are certain necessary requirements for wiring and fittings that you will need to adhere to if you are using the flow meter as a Division 1 device. See page numbers 22 and 23.**

Please let us know if we can assist you in any way with your Sage meter. If you have any questions regarding installation, operation, or features, call 866-677-SAGE (7243), or [visit our website](http://www.sagemetering.com) to contact a factory representative in your area. This manual is available to download with other product literature under Doc-Downloads at <https://sagemetering.com/product-literature-downloads/>.

Sincerely,



Bob Steinberg
President



SECTION A:

Getting Started

Unpacking Your Sage Meter

Your Sage flow meter is a sensitive, yet rugged, precision-built electronic instrument. Upon delivery, take care when opening the shipping container and removing your meter. Inspect the meter for any damage that may have occurred during transit. If there is any damage, please contact the carrier immediately to place a claim for damaged goods.

Check the contents of the container against the packing list for any discrepancies. If there are any questions as to the configuration of the equipment including calibration ranges, or mounting hardware, contact Sage Metering for assistance. Please save the shipping container and packaging materials (including PVC tube probe protector on Sage insertion flow meters) in case the unit needs to be returned for any reason.

Maintenance

Sage thermal mass flow meters require little or no maintenance. While the sensing element is somewhat resistant to dirt and particulate build-up, it may become necessary to clean it from time to time if mounted in exceptionally unclean environments. **Note: Always remove the power before any cleaning or**

maintenance. A detergent or appropriate non-corrosive solvent for removing the buildup may be required. A soft brush can be used to gently clean the sensing element's surface, using caution to avoid damaging the sensor elements (the RTDs). If any disassembly is necessary, contact Sage Metering for instructions. **When the meter requires cleaning, repair, or recalibration, returning the equipment to the factory has historically proven to be the most cost-effective and reliable choice.**

Calibration

Sage Paramount has continuous diagnostics. The raw calibration milliwatts (mW) is always displayed in the upper left-hand corner of the meter's display. At any time, you can check this reading at a "no flow" condition and compare the reading to the original reported "zero flow" value noted on the last few lines of your meter's Certificate of Conformance or the flow meter's data tag. This diagnostic procedure not only checks the sensor performance and the "live zero" calibration point, but it verifies that the sensor is clean. It principally provides a means to validate the meter's performance, verifies that there is no shift or drift. This simple field diagnostic procedure also verifies that the sensor is free from contamination, even without inspection.



CAUTION—The cable glands shipped with the unit are for shipping purposes only. Remove shipping cable glands before installing.



CAUTION— The installer must supply proper ground and bond wire for the transmitter and the sensor per appropriate electrical codes.

Installation and Mounting

EN60079-14 Standard for Electrical Installations

Check the Certificate of Conformance included with your Sage thermal mass flow meter for system pressure, temperature, gas composition, power input, and signal output.

Insert the flow meter in a location providing maximum straight run. Refer to Flow Conditioning and Straight Run on page 12. Note that obstructions such as valves, blowers, expanders, and PVC and HDPE pipes require additional straight run (contact the factory for assistance).

Check the display orientation—The standard calibration flow direction is left to right when facing the flow meter. Gas flow direction is marked by an arrow on inline flow meters, while **upstream** is marked on insertion probes. If the enclosure is facing *incorrectly*, rotate the enclosure 180°, but **never** rotate the probe, or errors may occur. The **upstream** mark still needs to be facing upstream.¹

Hook up the system by referring to the wiring diagram provided with your Sage flow meter

(see the inside of the rear compartment cover for silk-screened terminal designation). Verify that the wiring for the power and signal connections are correct.

Inspect that all the plumbing and electrical hook-ups comply with OSHA, NFPA, and all other safety requirements.

For remote-style meters (Model 402), **be sure the remote electronics match with the transmitter's junction box and its attached probe or flow body**. Match the serial numbers of the transmitter and remote electronics enclosure (on metal tags). **Do not mismatch the serial numbers or calibration errors occur.**

Locating Proper Wiring Diagram

See Appendix B on page 39 for electrical wiring of the Sage Paramount. The silk-screening on the terminal board under the back cover defines the wiring connections.

Note: Do not open the display side of the enclosure as there are no user-serviceable parts on that side.

¹ The integral-style Sage Paramount insertion meter has the display oriented as shown in Figure 6 on page 15. If the enclosure needs to be rotated, this can be performed in the field (see below). If, however, the display needs to be rotated, **do not** attempt this in the field and return the meter to Sage for modification. Complete an RMA form before returning the meter (see instructions on page 36).

The procedure for rotating the *enclosure* is:

1. Clamp the enclosure of the Paramount in a vise with the probe pointing up at the ceiling.
2. Take a 7/8" wrench and turn the probe to the proper orientation.
3. Lock the probe into its new position with a set screw (not provided).

Insertion Flow Meter Application

Flow Profile and Installation Considerations

Insertion flow meters are generally easier to install than inline flow meters; however, to perform correctly, they require proper installation and a well-developed flow profile. Please refer to the following sections, Probe Insertion Guideline (page 15), 1/2" Installation Depth Chart (page 16), and 3/4" Probe Installation Depth Chart (page 17).

Sage Valve Assembly Operation

Valve assemblies (SVA05LP, SVA05, and SVA07) are optional mounting hardware for insertion-style flow meters (see Figure 1). The hardware allows the removal of insertion-style meters for service, cleaning, recalibration, and relocation without the need to shut down the process. The probe insertion depth is adjustable to permit the sensor to be situated at the center, which optimizes measurement accuracy (refer to Figures 8 and 10 on pages 16 & 17). The ball valve seals off leaks of the process gas at the insertion point after removing the probe assembly. The assembly includes a valve, threadolet, compression fitting with Teflon ferrule, as well as a cable restraint, and two collar clamps (except for SVA05LP).

A threaded half coupling, as subsequently defined, must be fitted to the pipe/duct to which the insertion probe inserts. *Avoid T-fittings since they disturb the flow profile and reduce the measurement area.* Direct threading together (or with necessary bushings) of the retractor assembly may be required. In other cases, the threadolet must be welded in place, and a clearance hole must be drilled through the pipe/duct to accept the probe assembly. If the pipe/duct is under pressure during

installation, a hot tap drill (not available through Sage Metering) may be required.

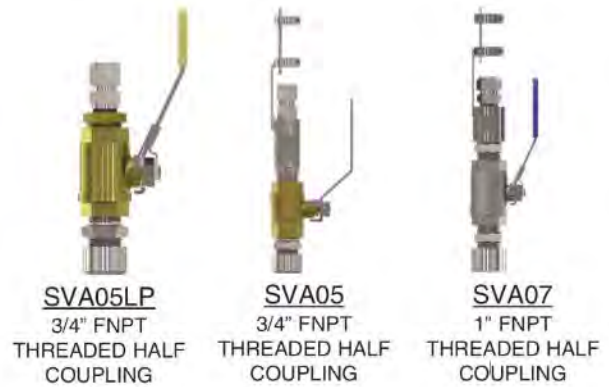

Figure 1

Flow Conditioning and Straight Run

To absolutely assure that the flow profile is well developed at the measurement point, either use flow conditioners (standard in Sage inline flow meters, 1/2" and larger, and optional assemblies for insertion flow meters) or consider an additional straight run. Figure 2 shows the amount of straight run needed to assure there are no flow disturbances at the measurement point.

IMPORTANCE OF FLOW CONDITIONING Recommended Pipe Diameters Upstream		
DISTURBANCE	Without Flow Conditioning	With Flow Conditioning ¹
	Minimum Industry Recommendation	Sage Recommendation
One 90° Elbow	25	3
Two 90° Elbows in the Same Plane	36	5
Two 90° Elbows in Different Planes	62	9
4:1 Area Reduction	18	3
4:1 Area Expansion	84	10
Multiple Disturbance	TBD	TBD

¹ This column applies to in-line flow meters, which come standard with built-in flow conditioners, as well as insertion meters, when installed with upstream Captive Flow Conditioners.

Figure 2

Compression Fitting Operation

A bored-through tube fitting, adequately sized to accommodate an insertion probe's particular OD, can be optionally purchased from Sage or provided by the user. Before installation, drill a clearance hole to accommodate the insertion probe assembly in the pipe/duct. A fitting (1/2" FNPT) is then welded in place or threaded into the half-threadolet which has been welded to the pipe/duct. The probe insertion depth is adjustable to permit the sensor to be located at the center, to optimize measurement accuracy. (Refer to Probe Insertion Guideline Drawing and Charts, pages 15–17.)



Figure 3 - Insert the probe shaft tubing into the compression fitting to the position indicated in the probe insertion guidelines.

Installation Instructions

1. Insert tubing into the tube fitting.
2. Make sure the tubing is adequately positioned per the Probe Insertion Guideline Drawing and Charts on pages 15–17.
3. Due to the variations of tubing diameters, a common starting point is desirable. Therefore, tighten the nut until the tubing does not turn by hand or move axially in the fitting.
4. Scribe the nut at the six o'clock position.
5. While holding the fitting's body steady, tighten the nut 1 1/4 turns to the nine o'clock position.



Figure 4 - While holding the fitting's body steady, tighten the nut one and one-quarter turns to the 9 o'clock position.

Captive Flow Conditioners

Captive Flow Conditioners are used with insertion-style flow meters.

IMPORTANT—The location of the probe must be one pipe ID diameter (such as 4" in a 4" pipe; 6" in a 6" pipe) downstream of the flow conditioner or errors occur. The Captive Flow Conditioners are always designed to be separated by one pipe diameter. See Figure 5.

IMPORTANT—When using Captive Flow Conditioners, it is essential to calibrate the accompanying Sage Flow Meter with the flow conditioner. **Do not** order a flow conditioner separate from the flow meter, unless the flow meter part number is “-FC.”

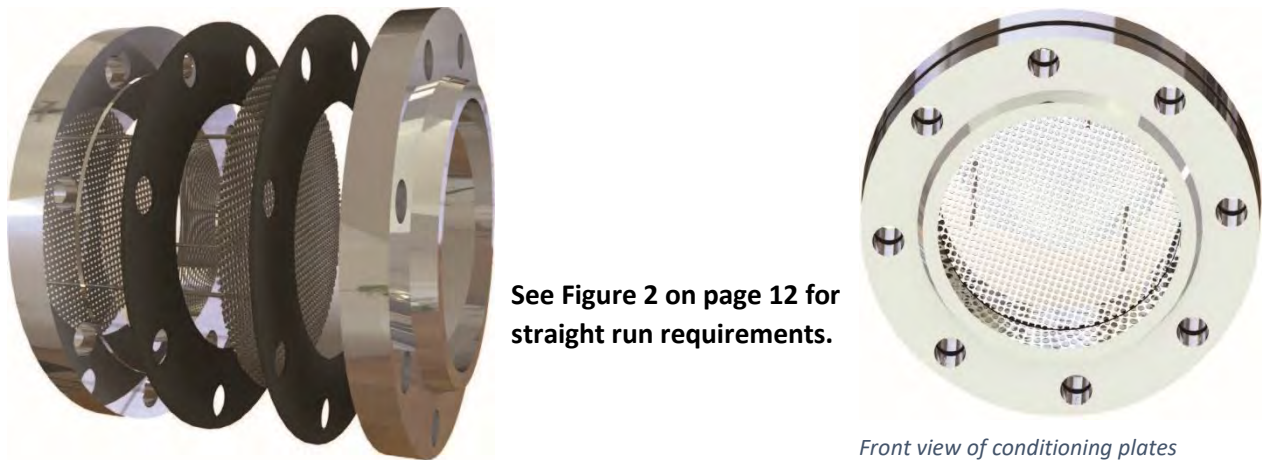
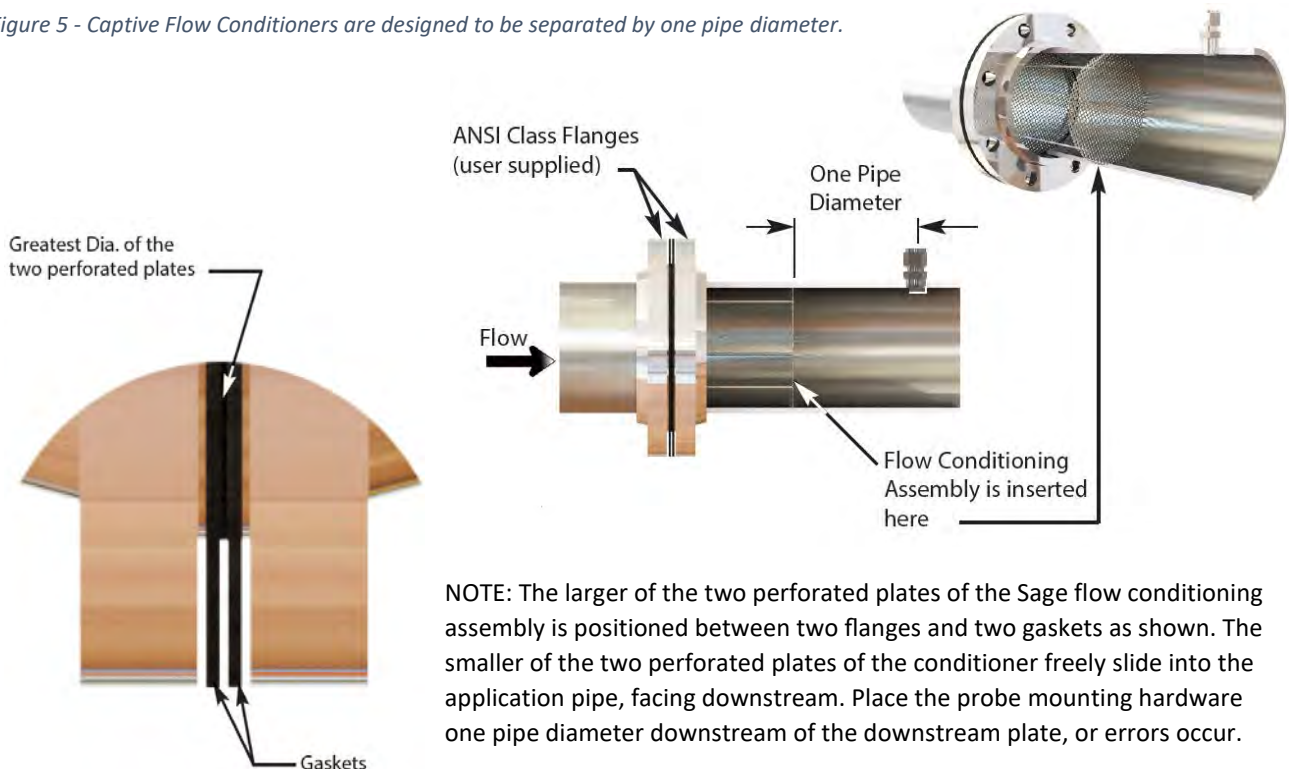

Figure 5 - Captive Flow Conditioners are designed to be separated by one pipe diameter.



NOTE: The larger of the two perforated plates of the Sage flow conditioning assembly is positioned between two flanges and two gaskets as shown. The smaller of the two perforated plates of the conditioner freely slide into the application pipe, facing downstream. Place the probe mounting hardware one pipe diameter downstream of the downstream plate, or errors occur.

Probe Insertion Guideline

Choose the longest straight-run section of pipe available to allow a uniform, well-developed flow profile. See Figure 2 on page 12 for recommended upstream pipe diameters. Note, obstructions such as valves, blowers, expanders, and PVC and HDPE pipes require additional straight run (contact the factory for assistance). Avoid, if possible, installations immediately downstream of bends, fans, nozzles, heaters and especially valves, or anything else installed in the line that may cause non-uniform flow profiles and swirls. Otherwise, signal output errors could result unless significantly more straight run is provided, or, flow conditioners are installed (contact Sage for assistance if needed). Refer to page 14 for the benefits of incorporating flow conditioners.

Insertion styles are available with a standard 1/2" OD probe support assembly. Standard probe lengths are 6", 12", 15", 18", 24", and 30". Optionally, 3/4" OD probes are available with standard probe lengths, as well as 36" and 48" lengths. A common method of mounting the probe assembly through a pipe wall or duct (if ambient air) is using a compression fitting (STCF05). A Sage valve assembly (SVA05) is useful and highly recommended for pressurized applications or other gases, and a natural gas flange mounting is optionally available.

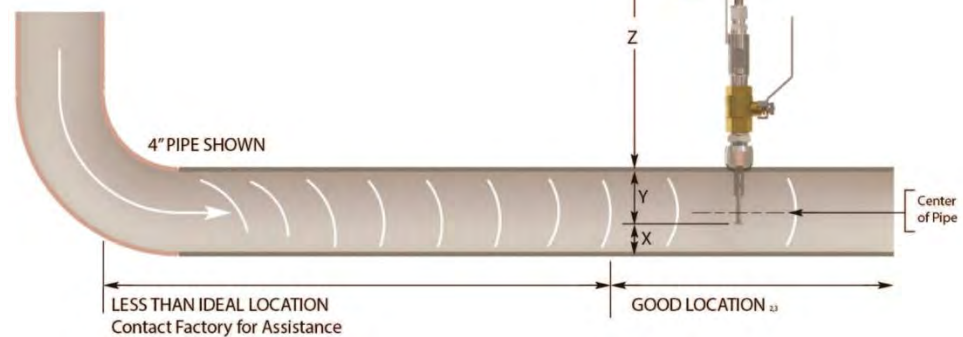

Figure 6

Sage insertion-style flow meters can be assembled and calibrated for use in virtually any size pipe or duct (as small as 1"). Sage insertion flow meters include a probe assembly that supports the sensing element (a self-heated flow sensor and a temperature/reference sensor); a sensor drive circuit; a microprocessor meter board, and transmitter enclosure. The probe assembly must be inserted into the correct position in the process gas flow conduit to allow the gas to flow through the sensor "window" across the sensor element. Position the "sensing point" or active part of the sensor (0.5" from the end of the probe) per Figure 6 and the Installation Depth Charts on pages 16 and 17.

Installation Depth

1. Figure 6 shows the Paramount Model 401 insertion meter.
2. The probe should be inserted per Installation Depth Chart (Figure 8 and 10) so that the sensors are in the center of the pipe.

1/2-Inch Probe Diameter Installation

Method 1

Using the chart (Figure 8), select pipe size (column 1) and determine X. Insert probe until the end touches the bottom of the pipe (ID), mark the probe as it exits the top of the fitting. Lift probe distance “X” and tighten the compression fitting.

Method 2

Using the chart below, select pipe size (column 1) and insert probe distance Y.

Please Note:

1. The 1” pipe size needs to have the probe “Bottomed Out” (option “BOT”).
2. For other pipe, such as Schedule 10, contact Sage; however, the Y dimension is the same for any schedule of pipe.

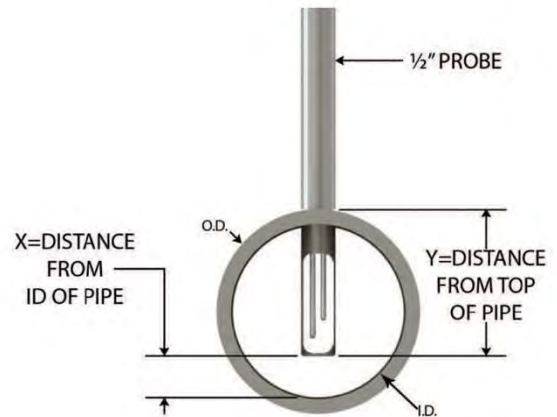

Figure 7

Figure 8 - 1/2” Probe Diameter Installation Chart

SCHEDULE 40 PIPE ²					
PIPE SIZE	OD	ID	X	Y	PIPE AREA
1” ¹	C O N S U L T F A C T O R Y				
1.5”	1.900	1.610	.20”	1.56”	0.0141
2”	2.375	2.067	.40”	1.82”	0.0233
2.5”	2.875	2.469	.60”	2.07”	0.0332
3”	3.500	3.068	.90”	2.38”	0.0513
4”	4.500	4.026	1.40”	2.86”	0.0884
6”	6.625	6.065	2.40”	3.95”	0.2006
8”	8.625	7.981	3.40”	4.90”	0.3474
10”	10.750	10.020	4.40”	6.00”	0.5476
12”	12.750	11.938	5.50”	7.00”	0.7773
14”	14.000	13.124	6.00”	7.50”	0.9394
16”	16.000	15.000	7.00”	8.60”	1.2272
18”	18.000	16.876	8.00”	9.60”	1.5533
24”	24.000	22.625	10.75”	12.60”	2.7919

SCHEDULE 80 PIPE ²					
PIPE SIZE	OD	ID	X	Y	PIPE AREA
1” ¹	C O N S U L T F A C T O R Y				
1.5”	1.900	1.500	.15”	1.56”	0.0123
2”	2.375	1.939	.35”	1.82”	0.0205
2.5”	2.875	2.323	.55”	2.07”	0.0294
3”	3.500	2.900	.80”	2.38”	0.0459
4”	4.500	3.826	1.30”	2.86”	0.0798
6”	6.625	5.761	2.25”	3.95”	0.1810
8”	8.625	7.625	3.25”	4.90”	0.3171
10”	10.750	9.750	4.25”	6.00”	0.5185
12”	12.750	11.374	5.13”	7.00”	0.7056
14”	14.000	12.500	5.70”	7.50”	0.8522
16”	16.000	14.312	6.60”	8.60”	1.1172
18”	18.000	16.124	7.50”	9.60”	1.4180
24”	24.000	21.562	10.25”	12.60”	2.5357

3/4-Inch Probe Diameter Installation

Method 1

Using the chart (Figure 10), select the pipe size (column 1) and determine X. Carefully insert the probe until the end touches the bottom of the

Please Note:

For other Pipe Schedules, such as Schedule 10, contact Sage; however, the Y dimension is the same for any schedule of pipe.

pipe (ID), mark the probe as it exits the top of the fitting. Lift the probe distance “X” and tighten the compression fitting.

Method 2

Using the chart below, select pipe size (column 1) and insert probe distance Y.

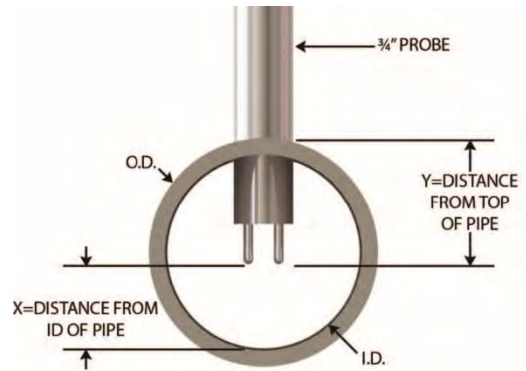

Figure 9

Figure 10 - 3/4" Probe Diameter Installation Chart

SCHEDULE 40 PIPE						SCHEDULE 80 PIPE					
PIPE SIZE (inches)	OD (inches)	ID (inches)	X (inches)	Y (inches)	PIPE AREA (ft ²)	PIPE SIZE (inches)	OD (inches)	ID (inches)	X (inches)	Y (inches)	PIPE AREA (ft ²)
1.5	1.900	1.610	0.63	1.10	0.0141	1.5	1.900	1.500	0.57	1.10	0.0123
2	2.375	2.067	0.86	1.34	0.0233	2	2.375	1.939	0.80	1.34	0.0205
2.5	2.875	2.469	1.07	1.59	0.0332	2.5	2.875	2.323	0.99	1.59	0.0294
3	3.500	3.068	1.37	1.90	0.0513	3	3.500	2.900	1.28	1.90	0.0459
4	4.500	4.026	1.85	2.40	0.0884	4	4.500	3.826	1.75	2.40	0.0798
6	6.625	6.065	2.87	3.47	0.2006	6	6.625	5.761	2.72	3.47	0.1810
8	8.625	7.981	3.83	4.47	0.3474	8	8.625	7.625	3.66	4.47	0.3171
10	10.750	10.020	4.85	5.53	0.5476	10	10.750	9.750	4.72	5.53	0.5185
12	12.750	11.938	5.81	6.53	0.7773	12	12.750	11.374	5.53	6.53	0.7056
14	14.000	13.124	6.41	7.15	0.9394	14	14.000	12.500	6.09	7.15	0.8522
16	16.000	15.000	7.35	8.15	1.2272	16	16.000	14.312	7.00	8.15	1.1172
18	18.000	16.876	8.28	9.15	1.5533	18	18.000	16.124	7.91	9.15	1.4180
24	24.000	22.625	11.16	12.15	2.7919	24	24.000	21.562	10.63	12.15	2.5357

Recommended Probe Lengths Data Sheet

SAGE - Revised May 2018	1/2" PROBE (- 05)	1/2" PROBE (- 05)	1/2" PROBE (- 05)	3/4" PROBE (- 07X)
	STCF05 height	SVA05LP height	SVA05 height	SVA07 height
Pipe size	Recommended probe length	Recommended probe length	Recommended probe length	Recommended probe length
1	6	12	15	N/A
1 1/2	6	12	15	18
2	6	12	15	18
2 1/2	6	12	15	18
3	6	12	15	18
3 1/2	6	15	15	18
4	6	15	15	18
6	12	15	18	18
8	12	15	18	24
10	12	18	18	24
12	12	18	24	24
14	12	18	24	24
16	12	20	24	24
18	15	20	24	24
20	15	22	24	30
24	18	24	30	30
36	24	30	36	36

Figure 11

Inline Flow Meter Application

Inline mounting styles are available in sizes 1/4" through 4" pipe. Threaded male NPT ends are standard up to 2 1/2" with ANSI 150 lb. flanged ends recommended for 3" and 4" models. Contact Sage Metering if optional end mounting styles are required. Pipe sizes over 4" require the insertion-style mass flow meter.

The inline-style flow meter assembly flow section is typically specified to match the user's flow conduit and plumbed directly in the flow line by threading, flanging, or welding. **Do not**

use reducers. The meter includes the sensing element (a self-heated flow sensor and a temperature/reference sensor) mounted directly in the specified flow section for exposure to the process gas; a sensor drive circuit; microprocessor meter board, and transmitter enclosure.

All inline flow meters, 1/2" and up have built-in flow conditioners. See Figure 2 on page 12 for upstream straight run requirements. Note, the 1/4", and 3/8" do not have flow conditioners and thus require more straight run.

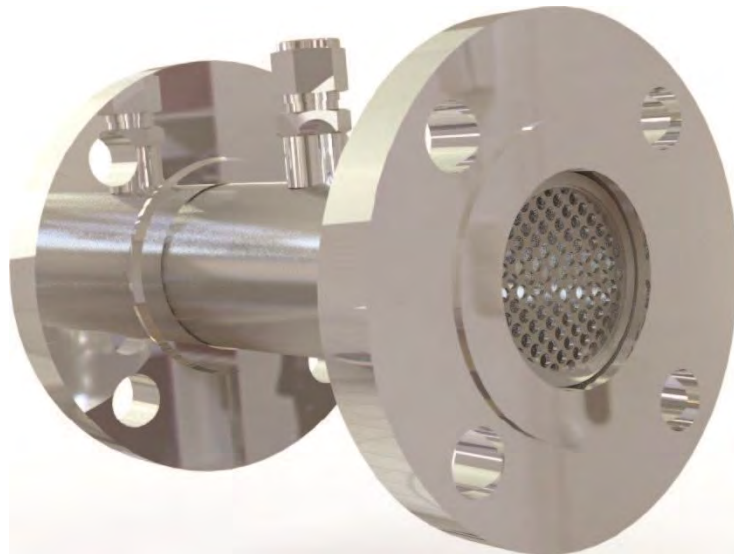

Figures 12 – Above image shows screens with NPT fitting

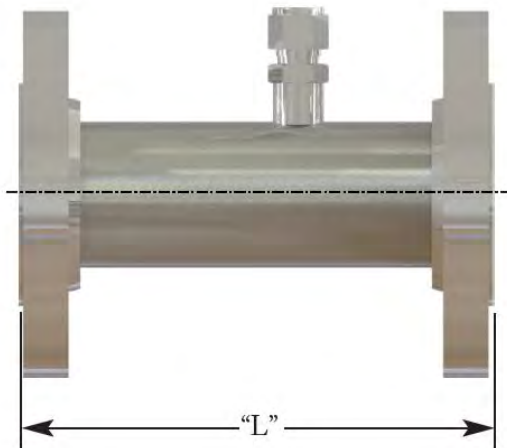

IN-LINE METER DIMENSIONS MNPT/FLANGE	
PIPE SIZE (DIAMETER) x "L" (LENGTH)	
1/8" x 6"	1-1/4" x 10"
1/4" x 6"	1-1/2" x 12"
1/2" x 7"	2" x 12"
3/4" x 7"	2-1/2" x 12"
1" x 8"	3" x 12"
	4" x 12"



Figure 13 – The length of the flanged-flow body is the same as the NPT-flow body.

SECTION B:

Styles and Features

Principle of Operation of the Thermal Mass Flow Meter

Sage thermal mass flow meters have two sensors constructed of reference-grade platinum windings (RTDs). The two RTDs are clad in a protective 316SS or Hastelloy C sheath and driven by a proprietary sensor drive circuit. One of the sensors is self-heated (flow sensor), and the other sensor (temperature/reference sensor) measures the gas temperature. The pair is referred to as the sensing element and is either installed in a probe as an Insertion style or inserted into a pipe section as an inline-style flow meter.

As gas flows by the flow sensor, the gas molecules carry heat away from the surface, and the sensor cools down as it loses energy. The sensor drive circuit replenishes the lost energy by heating the flow sensor until it is a constant temperature differential above the reference sensor. The electrical power required to maintain a

constant temperature differential is directly proportional to the gas mass flow rate and is linearized to be the output signal of the meter.

This constant temperature differential must be maintained, even if there are wide fluctuations in gas temperature. It is the function of the Sage hybrid-digital proprietary sensor drive circuit to keep the differential, whether or not the gas temperature changes, or however quickly molecules cool off the flow sensor. It is also necessary to properly calibrate the device with the actual gas (or close equivalent with certain gases), in the Sage National Institute of Standards certified (NIST) calibration facility. By accomplishing these two critical objectives, the Sage meters provide an extremely repeatable (0.2% of Full Scale) and accurate output directly proportional to the mass flow rate of the gas being measured.



Figure 14 - One of the sensors is self-heated, and the other sensor measures the gas temperature.

Approvals

Class I Div 2 Hazardous Location¹

All 24 VDC-powered Sage Paramount Meters (401 Integral Insertion, 401 Inline, 402 Remote Insertion, 402 Remote Inline) are either Class I, Div 2, Groups B, C, D, T4 and ATEX: Ex nA IIC T4 or Class I Div 1 approved.

AC-powered meters are not CID2 approved.

Testing under the following safety standards:

- ANSI 12.12.01, Electrical Equipment for Use in Class I and II, Division 2, and Class III Hazardous (Classified) Locations
- CSA C22.2 No. 213-M1987 (R1999), First Edition, Nonincendive Electrical Equipment for Use in Class I, Division 2 Hazardous Locations
- UL/CSA 61010-1, Second Edition, Safety Requirements for Electrical Equipment for Measurement, Control, and Laboratory Use—Part 1: General Requirements

The following is required to comply with the approvals mentioned above:

1. Repair of the product (or replacement of components) is not possible by the user
2. As noted on the label shown above, there are the following markings: Ex symbol, nA symbol IIC, temperature class
3. All Paramount 24 VDC meters are marked with “X” which means that these Special Conditions of Use applies:
 - a) The completed meter must be installed with a rigid or flexible metal conduit to satisfy approval conditions.



Figure 15

b) The meter is approved for use with the electronics enclosure in ambient temperature from $-40^{\circ}\text{C} < T_a < 65^{\circ}\text{C}$.

Conformance

Class I Div 1 & Class I Div 2

All AC & DC Powered Sage Metering Series 400 (Sage Paramount 401), and Series 402 (Sage Paramount- 402) are CE Compliant for the following CE directives:

- EN61000-6-4 for Electromagnetic compatibility
- EN61000-3-2 for Harmonics
- EN61000-3-3 for Flicker
- EN61000-6-2 for Electromagnetic Compatibility (Immunity for Industrial Environments), which includes EN61000-4-2 for ESD
- EN61000-4-3 for Radiated Immunity
- EN61000-4-4 for EFT/B; EN61000-4-5 for Surge
- EN61000 for Conducted Immunity
- EN61000-4-8 for Magnetic Immunity
- EN61000-4-11 for Voltage Interruptions

¹ CRN approval is optional on certain models. Contact Sage

Class I Div 1 Hazardous Location¹

All Sage Paramount Meters are Class I Div 1 approved - 24VDC as well as 110VAC.

Testing was conducted under the following safety standards:

- UL 913
- 7th edition
- IEC 60079 series

The following is required to comply with the approvals mentioned above:

4. Repair of the product (or replacement of components) is not possible by the user.
 - a) The completed meter must be installed with fittings and connections as defined on pages 23 & 24.



¹ CRN approval is optional on certain models. Contact Sage

Paramount Remote Sensor | CID1 Approved LABEL COMPLIANCE

In order to maintain the Class I Division 1 approval, the CID1 edict has defined compliance for the completion of the Paramount Meter and the Remote Sensor assembly as, *(1) completed meter must be installed with seal fittings and connections defined as follows:*

Install the Killark seal hardware per Killark assembly instructions (package enclosed) or in this Manual on pages 27–31. After the set-up period, thread Killark seal hardware to Remote sensor with Teflon tape (*polytetrafluoroethylene (PTFE)*). Attach discrete conductor wires to Remote Sensor PCBA. Insert a cable gland onto the cable, threads facing Killark seal. Insert a second cable gland onto the cable, threads facing LEFT/RIGHT meter port. Slide first cable gland to Killark seal of Remote Sensor. Route cable per field requirements and connect discrete conductor wires of cable to Terminal block PCBA of your Paramount Meter. Tighten both cable glands.

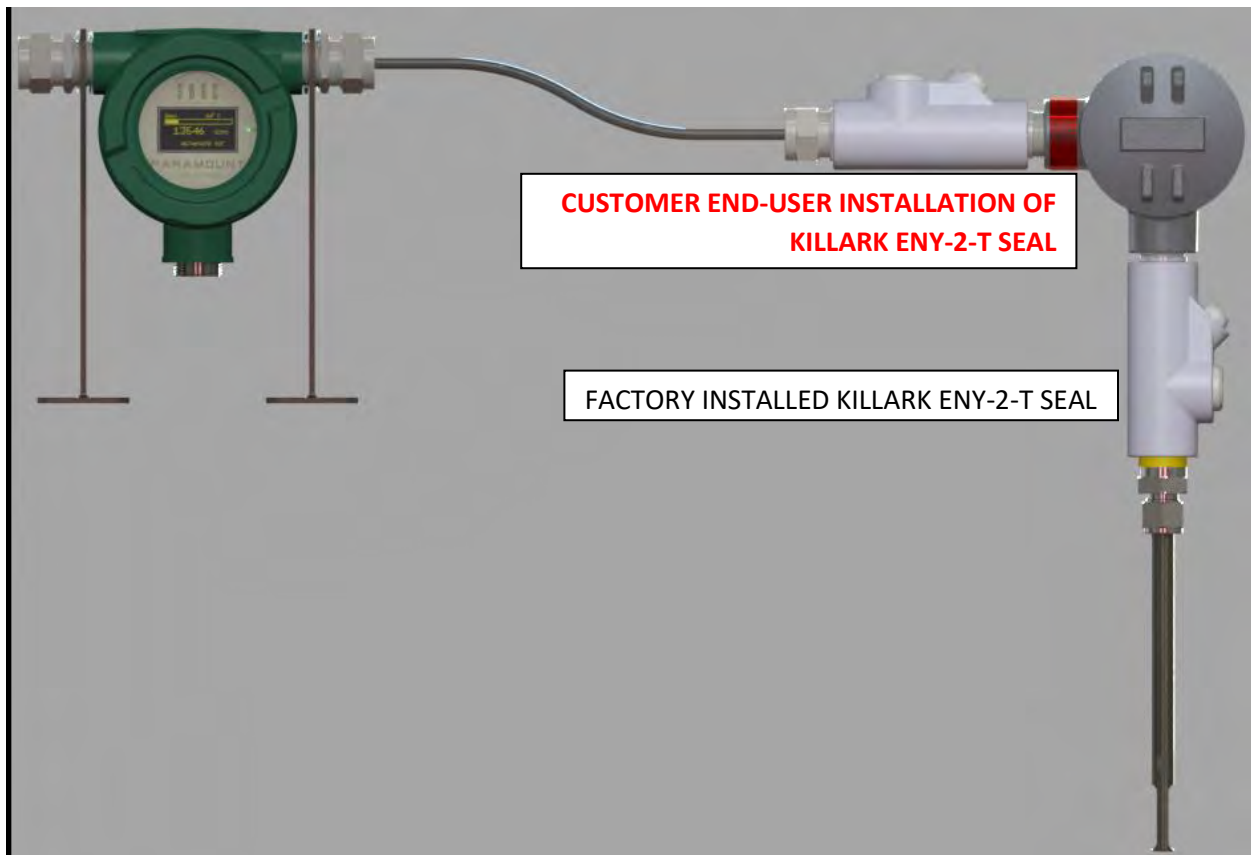

CID1 THREAD REQUIREMENTS

Lp.	Connection type		Requirements of FM 3615 CSA C22.2 No. 30 60079-1	Achieved values			
1	M100×2 6H/6g		threads engaged ≥ 7	9			
			width of engagement ≥ 12,5mm	18,5mm			
2	D ₁ proces opening	M20×1.5 6H M24×1.5 6H M25×1.5 6H	class 2 fit	l ₁	6g of male thread should be ensured by customer	L ₁	6H/6g
			threads engaged ≥ 5		should be ensured by customer, possible to reach: 12,5		6,5
			depth of engagement ≥ 8 mm		should be ensured by customer, possible to reach: 19mm		10mm
		M27×2 6H	class 2 fit	l ₁	6g of male thread should be ensured by customer	L ₁	6H/6g
			threads engaged ≥ 5		should be ensured by customer, possible to reach: 9		5
			depth of engagement ≥ 8 mm		should be ensured by customer, possible to reach: 19mm		10mm
	½NPTmod ¾NPTmod	threads engaged ≥ 5	l ₁	should be ensured by customer, possible to reach: 5,0 ÷ 5,5	L ₁	5	
	3	D ₂ , D ₃ conduit openings	M20×1.5 6H M24×1.5 6H M25×1.5 6H	class 2 fit	l ₂ , l ₃	6g of male thread should be ensured by customer	L ₂ , L ₃
threads engaged ≥ 5				should be ensured by customer, possible to reach: 12,5		6,5	
depth of engagement ≥ 8 mm				should be ensured by customer, possible to reach: 19mm		10mm	
½NPTmod ¾NPTmod			threads engaged ≥ 5	l ₂ , l ₃	should be ensured by customer, possible to reach: 5,0 ÷ 5,5	L ₂ , L ₃	5
4		Cemented joint		min. joint length 10mm	11mm		
5	Cilindrical joint Ø22H8		NOT tested as a flameproof joint.				

NPT threads are modified to reach 5+5,5 engaged threads and can create flameproof joint with threaded male part with standard cutting tolerance.

Only NPT threads can be used for CSA Division, in all openings.

DIAGRAM: CID1 THREAD CALLOUTS

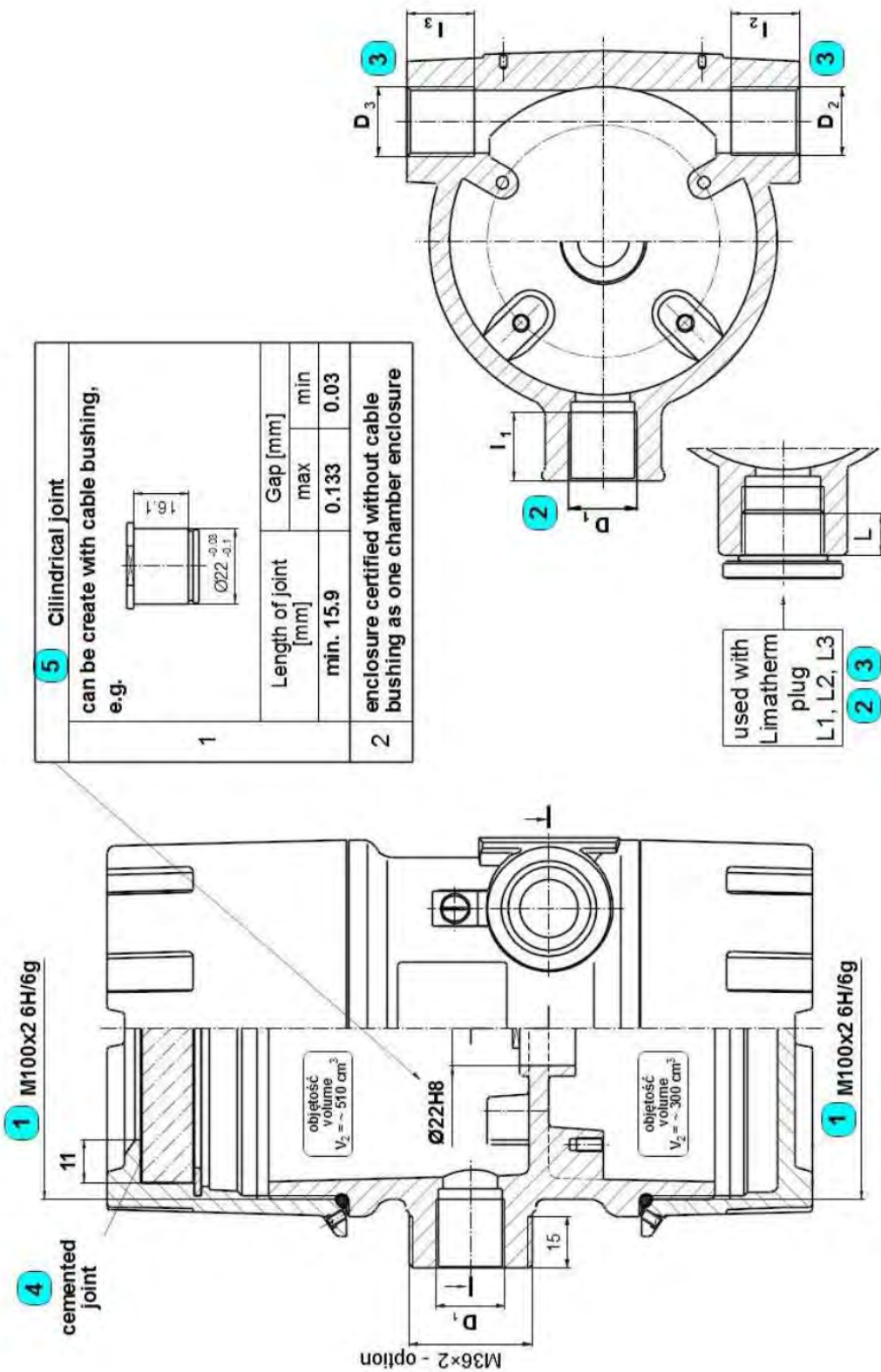



HUBBELL ELECTRICAL PRODUCTS
 A Division of HUBBELL INC. (Delaware)
 2112 Fenton Logistics Park Blvd.
 Fenton, Missouri 63028 USA

**INSTALLATION, OPERATION &
 MAINTENANCE DATA SHEET
 ENY SEAL FITTINGS**

For use in Zone Classified Hazardous Locations

ENY SEALING FITTINGS

CAUTION: Before installing, make sure you are compliant with area classifications, failure to do so may result in bodily injury, death and property damage. Do not attempt installation until you are familiar with the following procedures. All installation must comply with the applicable Electrical Code.

Make sure that the circuit is De-energized before starting installation or maintenance.

Verify that the installation is grounded. Failure to ground will create electrical shock hazards, which can cause serious injury and or death.

Technical information, advice and recommendations contained in these documents is based upon information that Killark believes to be reliable. All the information and advice contained in these documents is intended for use only by persons having been trained and possessing the requisite skill and know-how and to be used by such persons only at their own discretion and risk. The nature of these instructions is informative only and does not cover all of the details, variations or combinations in which this equipment may be used, its storage, delivery, installation, check out, safe operation and maintenance. Since conditions of use of the product are outside of the care, custody and control of Killark, the purchaser should determine the suitability of the product for his intended use and assumes all risk and liability whatsoever in connection therewith.

- For vertical and horizontal conduit installations use Killark "PF" Packing Fiber to build a dam at each conduit hub except for upper hubs in the vertical position as shown in Installation Drawings. Use a wooden stick to force the wires apart and pack the fiber tightly around all wires. The dam must be tight and strong enough to keep the sealing compound from leaking out before it sets up. The completed dam should be even with the conduit stops as shown.
- When using Killark Type "SC" Sealing Compound, mix the sealing compound with water at a rate of 3.3 parts of compound to 1-part water by volume (4 to 1 by weight). Use a clean mixing vessel for each batch. Sprinkle the sealing compound into water while stirring; continue mixing for at least 3 MINUTES. The proper consistency is just fluid enough to pour SLOWLY, like thick gravy (NOT WATERY) and should have a smooth silky shimmer in appearance when mixed correctly. Do not mix more material than can be poured in 15 minutes. Discard any sealing compound that has become too stiff to use. Never attempt to restore workability by stirring in more water. After the compound is mixed properly, slowly pour it into the sealing fitting. Make sure the wires are separated so the compound will completely surround them. Pour slowly to avoid trapping air bubbles in the compound and fill to the required level shown in Table 1.

CAUTION: FOR GROUPS A, B, C & D
 Sealing compound to be mixed at a temperature no lower than 40°F/4°C and ONLY poured into fittings that have been brought to a temperature of 40°F/4°C. Seals must NOT be exposed to temperatures below 40°F/4°C for at least 72 hours. Compound MUST be allowed 72 hours to cure to full strength before energizing system.

CAUTION: FOR GROUPS C & D
 Sealing compound to be mixed at a temperature no lower than 35°F/2°C and ONLY poured into fittings that have been brought to a temperature of 35°F/2°C. Seals must NOT be exposed to temperatures below 35°F/2°C for at least 8 hours.

SC SEALING COMPOUND

CATALOG NO.	CONDUIT SIZE	POUR DEPTH (MIN.)	REQUIRED AMOUNT MIXED (OZ.)
ENY-1	½"	¾"	1.0
ENY-2	¾"	¾"	1.5
ENY-3	1"	1"	2.5
ENY-4	1 ¼"	1 ¼"	5.5
ENY-5	1 ½"	1 ½"	7.5
ENY-6	2"	2"	10.5

TABLE 1



HUBBELL ELECTRICAL PRODUCTS
 A Division of HUBBELL INC. (Delaware)
 2112 Fenton Logistics Park Blvd.
 Fenton, Missouri 63026 USA

INSTALLATION, OPERATION & MAINTENANCE DATA SHEET
ENY SEAL FITTINGS
 For use in Zone Classified Hazardous Locations

- When using Killark QQS "CELOX" Sealing Compound, remove cap by twisting 90° counterclockwise for 50mL cartridge. For larger 250mL cartridge unscrew cap counterclockwise and remove plug (Plug can be saved for re-use of cartridge). Place mixing nozzle onto cartridge and lock into place by twisting 90° for 50mL and screw clockwise for 250mL cartridge. Place 50mL cartridge into the dual dispensing applicator and 250mL cartridge into a high ratio caulking tool. Prime mixing nozzle by depressing handle and pump a small amount of sealing compound through nozzle until a uniform mixture is dispensed.
- Insert mixing nozzle into the seal fitting and fill to the required level shown in Table 2. Make sure the wires are well separated so the compound completely surrounds them. Dispense slowly to avoid trapping air bubbles in the compound. Immediately wipe any spilled compound from conduit and threads, and close the fitting with close-up plug.

CAUTION: FOR GROUPS A, B, C & D (LOW AMBIENT TEMPERATURES)

QQS Sealing Compound is to be dispensed at temperatures no lower than 40°F/4°C and ONLY poured into fittings that have been brought to a temperature of 40°F/4°C. Seals must not be exposed to temperatures below 40°F/4°C for at least 8 hours. Compound MUST be allowed 8 hours to cure (See QQS Cure Time vs. Temperature Chart 1).

CAUTION: TO PREVENT PERSONAL INJURY & IGNITION OF HAZARDOUS ATMOSPHERES

QQS sealing compound releases heat energy from exothermic reaction after dispensing. The sealing compound is to be fully cured before handling and exposing to hazardous atmospheres. (See QQS Cure Time vs. Temperature Chart 1)

QQS SEALING COMPOUND

CATALOG NO.	CONDUIT SIZE	POUR DEPTH MINIMUM (in)
ENY-1	½"	1.38
ENY-2	¾"	1.62
ENY-3	1"	1.94
ENY-4	1 ¼"	2.19
ENY-5	1 ½"	2.90

TABLE 2

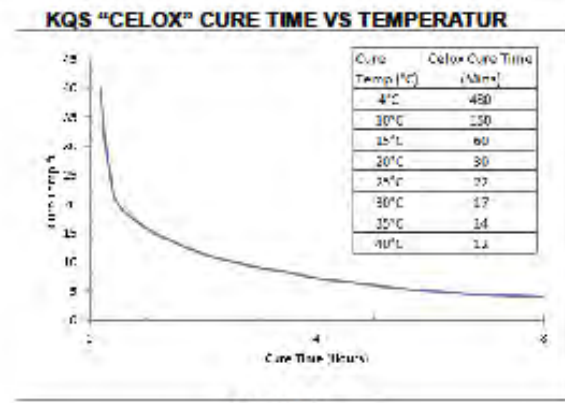
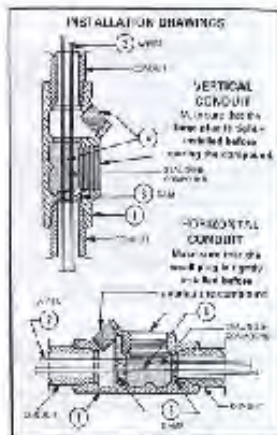

CHART 1



KILLARK

HUBBELL ELECTRICAL PRODUCTS
A Division of HUBBELL INCORPORATED (Delaware)
3940 Dr. Martin Luther King Drive
St. Louis, Missouri 63113 USA

INSTALLATION, OPERATION & MAINTENANCE DATA SHEET

**SUPPLEMENTAL DATA SHEET
Sealing Fittings for Use in Hazardous
(Classified) Locations**

SUPPLEMENTAL DATA SHEET

Table 102.1

**RECOMMENDED MAXIMUM NUMBER OF WIRES
THAT CAN BE PROPERLY SEALED IN A SEALING FITTING IN THE FIELD**

The maximum number of wires^{a,b} that can be sealed in a sealing fitting are as follows:

Size AWG or kcmil	1/2 Inch 16 Metric Designator		3/4 Inch 21 Metric Designator		1 Inch 27 Metric Designator		1-1/4 Inch 35 Metric Designator		1-1/2 Inch 41 Metric Designator		2 Inch 53 Metric Designator		2-1/2 Inch 63 Metric Designator		3 Inch 78 Metric Designator		3-1/2 Inch 91 Metric Designator		4 Inch 102 Metric Designator		5 Inch 129 Metric Designator		6 Inch 155 Metric Designator		
	A	B	A	B	A	B	A	B	A	B	A	B	A	B	A	B	A	B	A	B	A	B	A	B	
10	7	11	12	20	12	20	20	33	35	58	49	60	60	131	115										
16	8	8	10	16	17	27	17	27	30	47	41	54	18	100	88										
14	8	8	8	15	10	24	10	24	18	48	25	58	41	161	58	80			121						
12	8	8	8	14	8	18	8	18	15	32	21	43	34	71	50	102	25	103							
10	1	1	1	7	7	11	10	20	10	20	20	27	29	45	41	65	64	100	36	104	110				
8	1	2	2	4	4	6	7	11	9	16	9	16	16	26	22	37	35	56	47	70	60	100	91		
6	1	1	1	2	2	4	4	7	6	9	10	16	16	23	18	23	23	28	32	47	41	61	64	96	
4	1	1	1	1	1	2	3	4	5	6	8	9	12	14	18	21	18	21	24	29	31	37	40	60	
3						2	3	3	4	6	7	8	10	12	16	18	16	18	21	24	28	31	44	60	
2						1	3	3	3	4	6	7	9	10	14	15	14	15	14	20	24	26	38	42	
1						1	1	1	1	1	1	1	1	1	1	1	1	1	1	1	1	1	1	1	
0						1	1	1	1	1	1	1	1	1	1	1	1	1	1	1	1	1	1	1	
2/0						1	1	1	1	1	1	1	1	1	1	1	1	1	1	1	1	1	1	1	
3/0						1	1	1	1	1	1	1	1	1	1	1	1	1	1	1	1	1	1	1	
4/0						1	1	1	1	1	1	1	1	1	1	1	1	1	1	1	1	1	1	1	
150						1	1	1	1	1	1	1	1	1	1	1	1	1	1	1	1	1	1	1	
300						1	1	1	1	1	1	1	1	1	1	1	1	1	1	1	1	1	1	1	
350						1	1	1	1	1	1	1	1	1	1	1	1	1	1	1	1	1	1	1	
400						1	1	1	1	1	1	1	1	1	1	1	1	1	1	1	1	1	1	1	
500						1	1	1	1	1	1	1	1	1	1	1	1	1	1	1	1	1	1	1	
600						1	1	1	1	1	1	1	1	1	1	1	1	1	1	1	1	1	1	1	
700						1	1	1	1	1	1	1	1	1	1	1	1	1	1	1	1	1	1	1	
750						1	1	1	1	1	1	1	1	1	1	1	1	1	1	1	1	1	1	1	
800						1	1	1	1	1	1	1	1	1	1	1	1	1	1	1	1	1	1	1	
900						1	1	1	1	1	1	1	1	1	1	1	1	1	1	1	1	1	1	1	
1000						1	1	1	1	1	1	1	1	1	1	1	1	1	1	1	1	1	1	1	
1250						1	1	1	1	1	1	1	1	1	1	1	1	1	1	1	1	1	1	1	
1500						1	1	1	1	1	1	1	1	1	1	1	1	1	1	1	1	1	1	1	
1750						1	1	1	1	1	1	1	1	1	1	1	1	1	1	1	1	1	1	1	
2000						1	1	1	1	1	1	1	1	1	1	1	1	1	1	1	1	1	1	1	

^a Col. A = Types RPH, RH, RHH, RHW, THW, TW, XHHW (AWG 14 - 6), FEPR (AWG 6 - 2)
Col. B = FEP, THHN, THWN, TEN, PE, PGE, XHHW (AWG 4 - 2)(00 kcmil), FEPR (AWG 14 - 6)
^b Any combination of these wires not exceeding 25 percent of a cross section of the conduit for the fitting they fill may be used.





Killark Electric Manufacturing Company
 A Subsidiary of Hubbell Incorporated
 3940 Dr. Martin Luther King Drive
 St. Louis, MO 63113

INSTALLATION, OPERATION & MAINTENANCE DATA SHEET
TYPE "ENY" HORIZONTAL / VERTICAL SEALING FITTING
 SUITABLE FOR CLASS I, DIV. 1 & 2, GROUPS A, B, C & D
 AND CLASS II, DIV. 1 & 2, GROUPS E, F & G HAZARDOUS LOCATIONS.

Sealing fittings are installed in conduit runs to minimize the passage of gases, vapors, or flames from one portion of the electrical installation to another through the conduit, as well as to prevent precompression or "pressure-piling" of vapors or gases in conduit systems.

NOTE: Seals should be made only by experienced, careful persons in strict compliance with these instructions. Even slight variations can cause serious field problems. Read directions completely.

DIRECTIONS FOR INSTALLATION

- ① Using the drawings and chart at the right as a guide, install the sealing fitting into the conduit system. Refer to the National Electrical Code, Articles 501-5 and 502-5 for the regulations covering your specific application.
 - ② Pull the conductors (wires) through the conduit system.
 - ③ Using Killark Type "PF" Packing Fiber, build a dam at each conduit hub (except upper hubs in vertical seals.) Use a wooden stick to force the wires apart, and pack the fiber tightly around all wires. The dam must be tight and strong enough to keep the liquid sealing compound from leaking out before it sets up. The completed dam should be even with the conduit stop.
 - ④ Use **ONLY** Killark Type "SC" Sealing Compound with these fittings. The sealing compound is mixed with water at the rate of three (3) parts of sealing compound to one (1) part of water by volume. See chart to determine the amount of compound required for a specific fitting. Use a clean mixing vessel for each batch. Sprinkle the sealing compound into the water while stirring, until a thick paste is formed. Continue mixing for **AT LEAST THREE (3) MINUTES**. The proper consistency is just fluid enough to pour **SLOWLY**, like thick gravy, from an inverted container, **NOT WATERY**. Do not mix more material than can be poured in 15 minutes. Discard any material that becomes too stiff to use. Never attempt to restore workability by stirring in more water.
- After the compound is mixed, slowly pour it into the sealing fitting to the required level. Make sure that the wires are well separated, so the compound completely surrounds them. Pour slowly to avoid trapping air bubbles in the compound. Immediately wipe any spilled compound from conduits and threads, and close the fitting with the close-up plug. Make sure the plugs are tight.
- ⑤ Initial set of the sealing compound will occur within thirty (30) minutes. However, the compound requires a minimum of 8 hours above 32° F to develop sufficient strength to withstand explosion pressures.

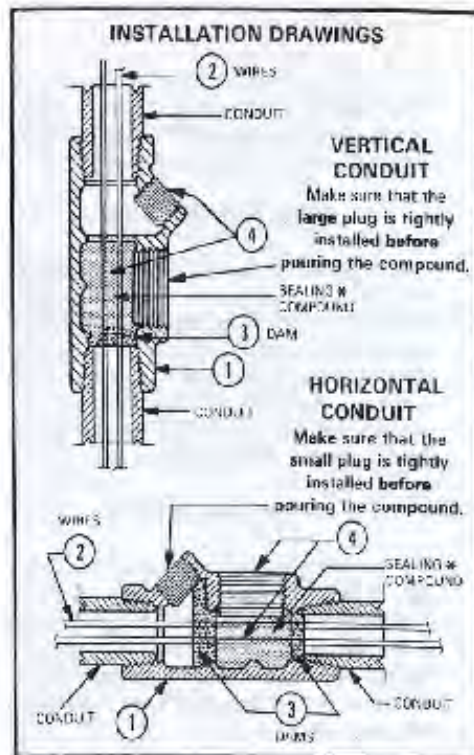

*NOTE: These fittings are approved for use only with Killark "SC" Sealing Compound.

CAT. NO.	CONDUIT SIZE	MIN. POUR DEPTH	APPROX. AMOUNT MIXED COMPOUND REQ'D. (OZ.)
ENY-1	½"	¾"	1.0
ENY-2	¾"	1"	1.5
ENY-3	1"	1"	2.5
ENY-4	1¼"	1¼"	5.5
ENY-5	1½"	1½"	7.5
ENY-6	2"	2"	10.5

IOM - "ENY" Sealing Fitting

OPERATIONAL DATA

In humid atmospheres or wet locations, where it is likely that water could enter the interior enclosures or conduit runs, or where temperature and/or barometric changes can produce condensation or moisture within the conduit system, raceways should be inclined so that the water will not collect in seals. It is recommended that Killark "EYD" draining seals be utilized to properly drain the system.

MAINTENANCE DATA

ENY sealing fittings require no special maintenance, other than a periodic inspection to be sure the close-up plugs are tight. In the event that a sealing fitting would be subjected to damage, the damaged parts should be replaced immediately to ensure the safety of the conduit system. Refer to the parts drawing at the right for replacement parts.

MAINTENANCE MANAGER: Please record the following information for your records:

COMPLETE CATALOG NO. _____
(As shown on package)

DATE OF INSTALLATION _____

REMEMBER TO SAVE A COPY OF THIS INFORMATION FOR MAINTENANCE PERSONNEL.

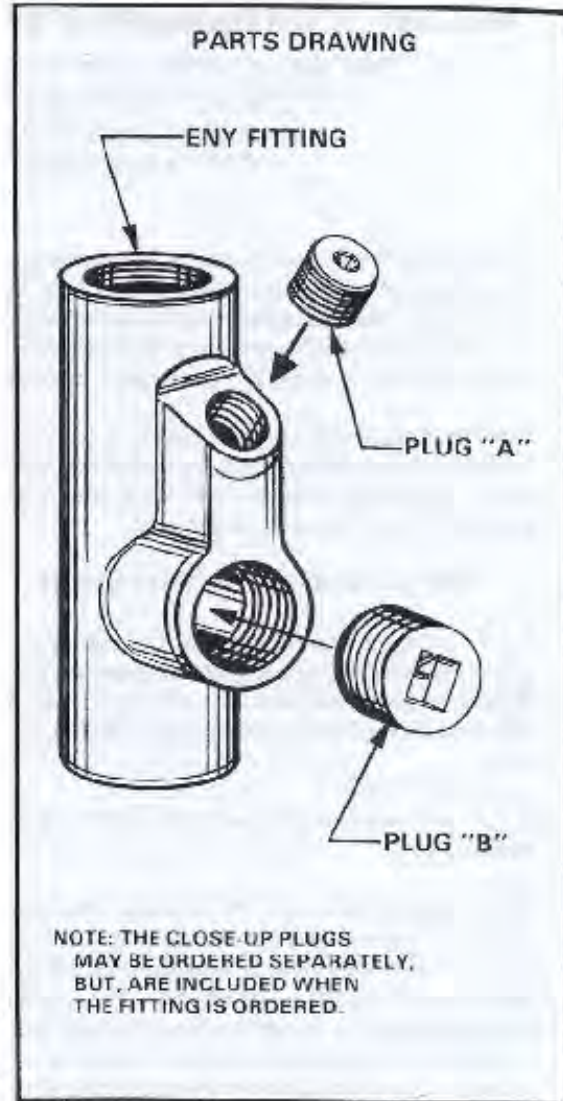

ALUMINUM FITTING CAT. NO.	PLUG "A" CAT. NO.	PLUG "B" CAT. NO.
ENY-1	CUP-250	CUP-2
ENY-2	CUP-375	CUP-2
ENY-3	CUP-375	CUP-3
ENY-4	CUP-1	CUP-4
ENY-5	CUP-1	CUP-5
ENY-5	CUP-2	CUP-5
IRON FITTING CAT. NO.		
ENY-1M	19861AAAB	PLUG 2
ENY-2M	19862AAAB	PLUG 2
ENY-3M	19862AAAB	PLUG 3
ENY-4M	PLUG 1	PLUG 4
ENY-5M	PLUG 1	PLUG 5
ENY-6M	PLUG 2	PLUG 6

SECTION C:

Diagnostics

Paramount Diagnostics

Symptom: Erratic readings

Possible Causes: If a large motor or generator or variable-frequency drive (VFD) is near the enclosure, it may be inducing sufficient analog noise into the circuitry to temporarily corrupt the data.

Suggested Corrective Action:

- a) If a power-restart temporarily solves the problem, then the noise source was likely the problem.
- b) To prevent subsequent problems, if using a remote-style meter, move the enclosure as far away as possible from the noise source (the motor or VFD).
- c) If using an integral-style meter, mount the meter in a different location (further from the source) or move the noise source away from the meter.

Symptom: Erratic readings on a remote meter

Possible Cause: In some cases, analog noise induced into the remote cable causing erratic, or climbing readings.

Suggested Corrective Action:

- a) Be sure the remote cable is installed in metal conduit and grounded on the transmitter end only.
- b) Avoid coiled cable, especially if not in metal conduit.
- c) Also, if extra cable exists, move the extra cable as far away as possible from any source of analog noise, such as large motors or VFDs.

Symptom: The meter is reading zero continuously, or full scale continually, or temperature reading is abnormally low (hundreds of degrees below zero).

Possible Causes/Suggested Corrective Action:

- a) A wire is likely loose. However, in rare cases, a sensor could fail if it exceeds a process temperature of 450°F.
- b) Check for continuity to be sure the wiring is making good contact at the terminals of the junction box.
- c) Verify that the electronics and the sensor serial numbers are the same. The sensor's serial number appears on the display during power-up, right after initializing. If the serial number doesn't agree with the junction box labels, that affects calibration (in other words, sensors and electronics are a matched pair and mixing them up causes false readings). Note—there are metal serial number tags fastened to the electronics and the junction box.
- d) It is easy to use the junction box on a remote style meter to check if a sensor has failed. To do so, you must power down (shut off power), but you do not need to remove the probe from the pipe. Refer to B10 page 39.
- e) An ohmmeter is required to check across the sensor leads of the flow sensor. Look at the drawing of the junction box. Disconnect the red wires on the factory side to isolate and measure the resistance. If the reading is infinity or a short, it means that the sensor failed.
- f) Now check the temperature sensor. Disconnect the white wires on the factory side to isolate and measure the resistance. If you have infinity or a short, it means that the sensor is burned out. Note: Normally the sensors read approximately 110 ohms at 70°F. At higher temperatures, they should read a high-

er resistance, but both sensors should have a similar value.

- g) On integral-style meters (Model 401), there is no junction box. In that case, refer to the Paramount integral terminals and check the sensor wires. Remove the appropriate wires first (the red pair for flow, then the white pair for temperature). Measure their resistance. If reading infinity or short, it means that the sensor has failed.

Symptom: Meter railing (pegging) or reading high

Possible Cause/Suggested Corrective Action:

- a) There is insufficient straight run (i.e., flow profile is disturbed, causing errors)
- b) A possible jet effect may exist if the upstream pipe is smaller than the meter flow body or if the valve is too close upstream to the meter.
- c) Are you following the probe insertion guideline (pages 15–17)?
- d) If the sensor is inserted in reverse (“Upstream” mark is facing downstream), the meter may over-report (or under-report) by as much as 30%.
- e) If the sensor is not aligned correctly, with the “Upstream” mark facing upstream, a rotation greater than ± 5 degrees may cause a change in reading (greater than ± 5 degrees and less than ± 20 degrees causes the meter to over-report; a greater rotation blocks the sensor and causes the meter to under-report).
- f) A downstream valve may be too close to the meter (flow may be reflecting back).
- g) Water droplets may be condensing out of the gas stream (causing the output to spike; but if droplets are near-continuous, the output may rail).

- h) The meter may be miswired, especially in a remote-style application.
- i) Water droplets may be condensing on the inside of the pipe wall, rolling down or hitting the sensor and causing the output to spike. If droplets are near-continuous, the output may rail. Note—Recommended installation 45° from vertical.
- j) Water droplets may condense out of the gas stream and fill the cavity containing the sensing elements (usually due to probes mounted below horizontal in saturated pipes).
- k) The sensor may be contaminated. Remove the probe, wipe off, or clean with a solvent. Reinsert.
- l) Are you using a different gas or gas mix than the meter was specified and calibrated?
- m) If Model 402 (remote-style meter), be sure the serial numbers of the junction box and the remote electronics are identical (if not, errors in calibration are inevitable). To confirm, verify that junction box serial number tag has identical serial numbers to the tag on the remote enclosure.
- n) The meter may appear to be reading high if the user is comparing Sage flow meter readings (SCFM) to an uncorrected volumetric device (ACFM). For example, at constant volume, a decrease in gas temperature increases the mass flow (SCFM). That is completely normal.

Symptom: Reading Low

Possible Causes:

- a) There is insufficient straight run (i.e., flow profile is disturbed, causing errors).
- b) A poor flow profile upstream (insufficient upstream straight run)

- c) Are you following the probe insertion guideline (pages 15–17)?
- d) If the sensor is inserted in reverse (“Upstream” mark is facing downstream), the meter may over-report (or under-report) by as much as 20%.
- e) If the sensor is not aligned correctly, with the “Upstream” mark facing upstream, a rotation greater than ± 5 degrees may cause a change in reading (greater than ± 5 degrees and less than ± 20 degrees causes the meter to over-report; a greater rotation blocks the sensor and causes the meter to under-report).
- f) The sensor may be contaminated. Remove the probe, wipe off, or clean with a solvent. Reinsert.
- g) Are you using a different gas or gas mix than the meter was specified and calibrated?
- h) If this pertains to a Model 402 (remote-style meter), be sure the serial numbers of the junction box and remote electronics are identical (if not, errors in calibration are inevitable). To confirm, verify that the junction box serial number tag is identical to that of the remote enclosure.
- i) The meter may appear to be reading low if the user is comparing Sage flow meter readings (SCFM) to an uncorrected volumetric device (ACFM). For example, at constant volume, an increase in gas temperature lowers the mass flow (SCFM). That is completely normal.
- j) On most models, the totalizer does not start counting for 10 seconds after power-up, so any flow data does not accumulate during this time.
- k) Do you have sufficient power supply (most products require a minimum 100 mA)?
- l) Is there an excessive load on the 4–20 mA? (To check if the problem is due to 4–20 mA output device, temporarily remove the device, and observe if the display reads as expected.)

Symptom: 4–20 mA output not tracking the flow rate display

Possible Causes:

- a) In normal operation (self-powered), the Mode switch must be in the center position (15 V Internally Isolated)

In an externally powered mode, the Mode switch must be in the upper position (Externally Powered).

RMA (Return Merchandise Authorization)

If a customer needs to return a meter to Sage please contact the Service Department via email at service@sagemetering.com.

You MUST include the serial number from the meter and the reason for returning the meter and/or the symptoms you're having.

Sage Service will email the customer an RMA# to track the return of the meter to Sage and instructions on our RMA process.

Or the customer can call our

Service Department at 831.242.2030

or Toll Free at 866.677.7243 for assistance.

Service Department hours:

MON – FRI

6:00AM to 3:30PM PST

TECHNICAL DRAWINGS

APPENDIX A:

Mechanical

A1: EXTERNAL DIMENSIONS FLOW METER

A2: EXTERNAL DIMENSIONS SENSOR PROBE LENGTH

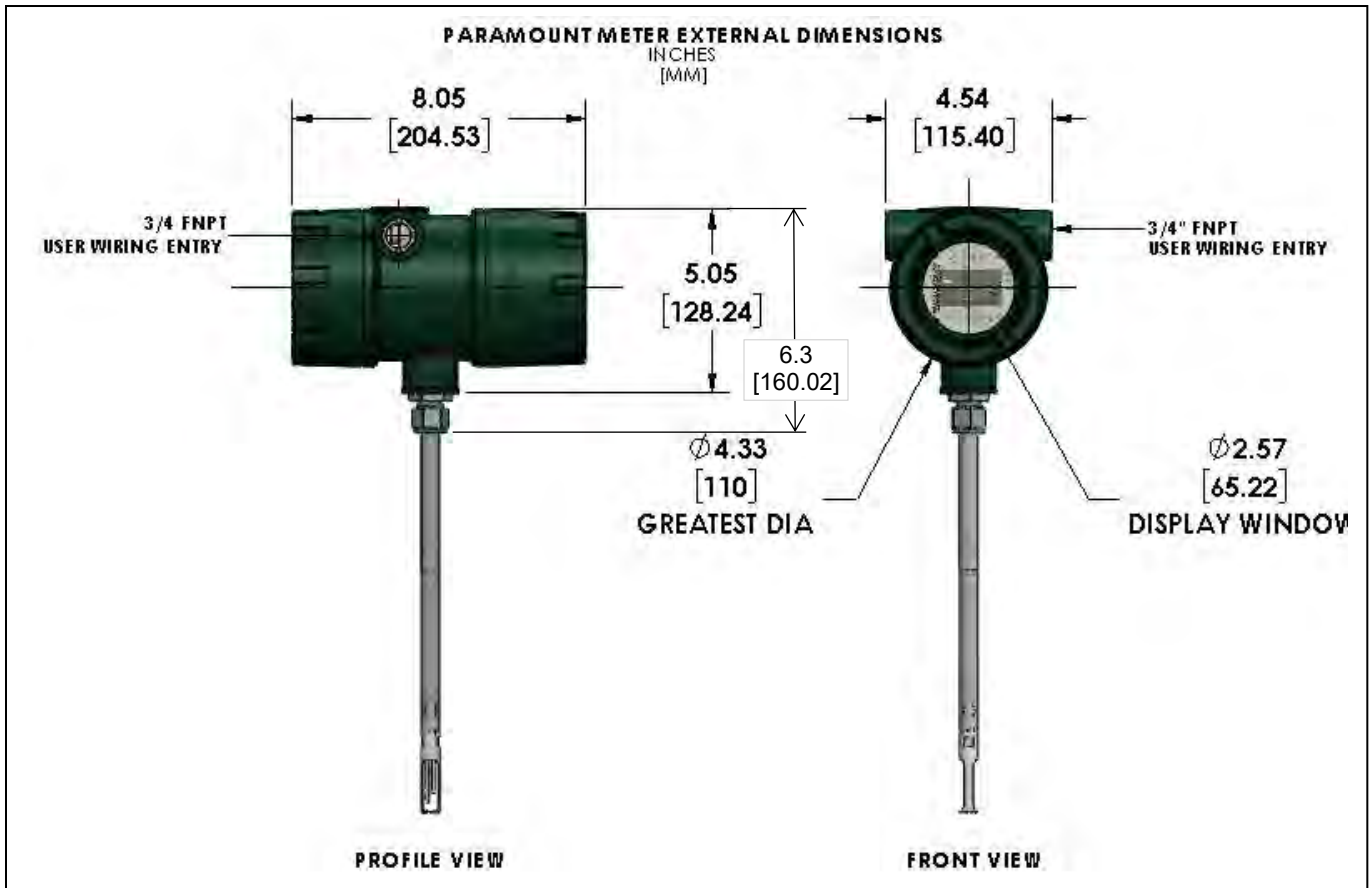

PROBE LENGTH for INSERTION METER MATRIX			
	STCF05/STCF07 COMPRESSION FITTING	SVA05 LP ISOLATION VALVE LOW PRESSURE	SVA05¹ / SVA07² ISOLATION VALVE HIGH PRESSURE
PIPE SIZE (NPS)	<125 PSIG	<50 PSIG	<250 PSIG
1" – 2.5"	6"	12"	15" / 18"
3" – 4"	6"	12" / 15"	15" / 18"
6" – 10"	12"	18"	18" / 24"
12" – 14"	12"	18"	24"
18" – 24"	15" / 18"	24"	24" / 30"
30" – 36"	24"	30"	36"

APPENDIX B:

Electrical Wiring

Make all wiring connections in the terminal block compartment of the enclosure.

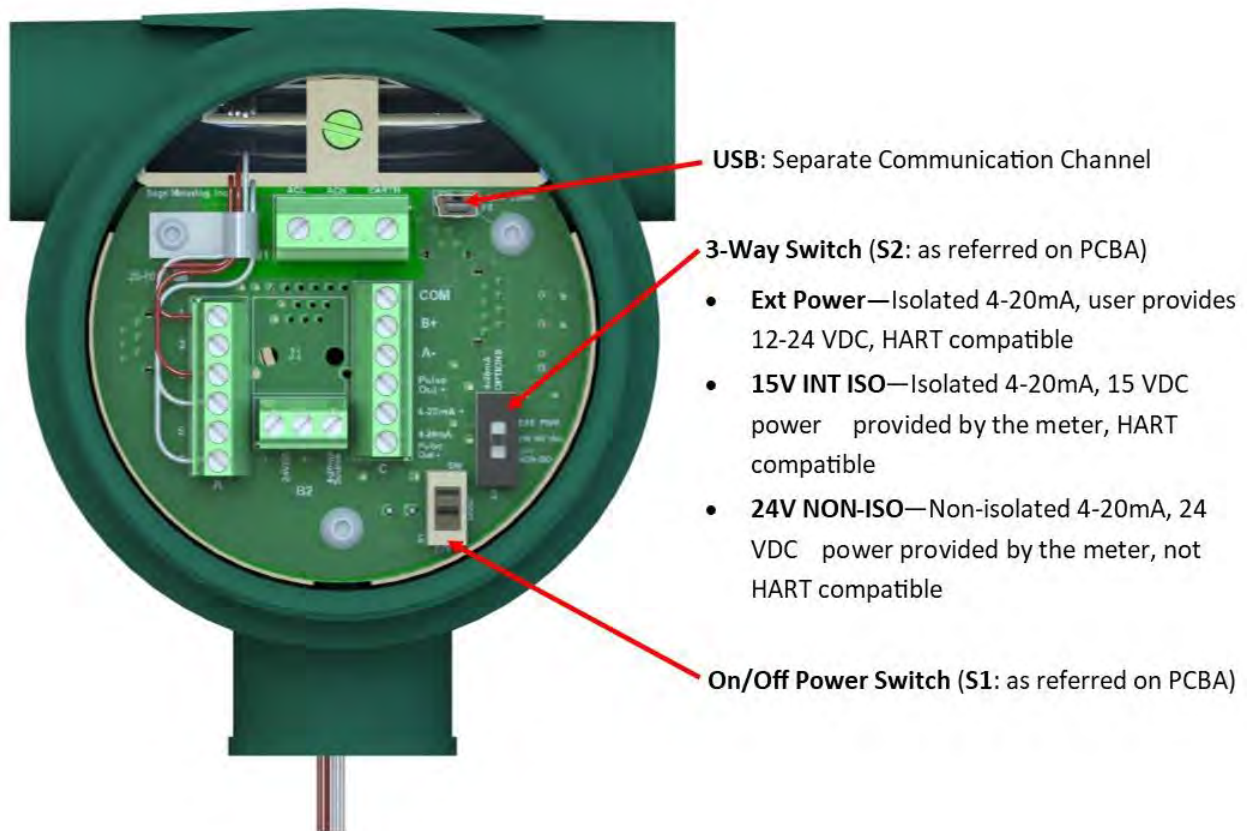

USB: Separate Communication Channel

3-Way Switch (S2: as referred on PCBA)

- **Ext Power**—Isolated 4-20mA, user provides 12-24 VDC, HART compatible
- **15V INT ISO**—Isolated 4-20mA, 15 VDC power provided by the meter, HART compatible
- **24V NON-ISO**—Non-isolated 4-20mA, 24 VDC power provided by the meter, not HART compatible

On/Off Power Switch (S1: as referred on PCBA)

Input Power

The power requirement at 24 VDC is 2.4 watts.

NOTE: Hazardous area approval is only available on 24 VDC units.

**24VDC POWERED
15VDC or 24VDC 4-20mA
15VDC OR 24VDC PULSE OUTPUT**

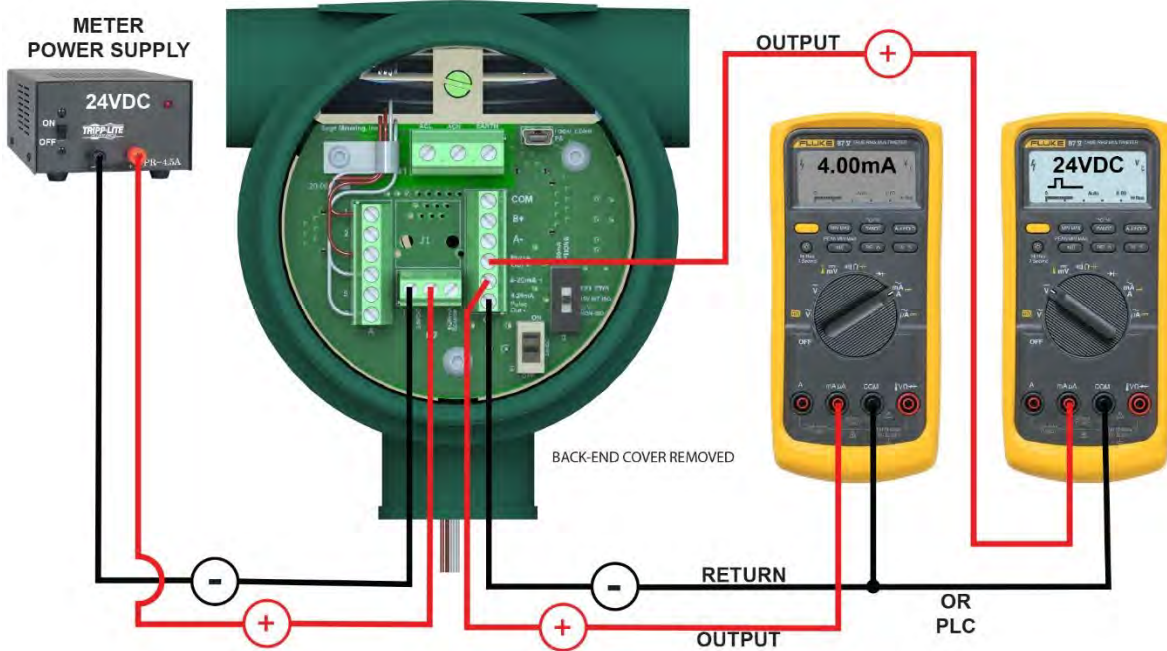
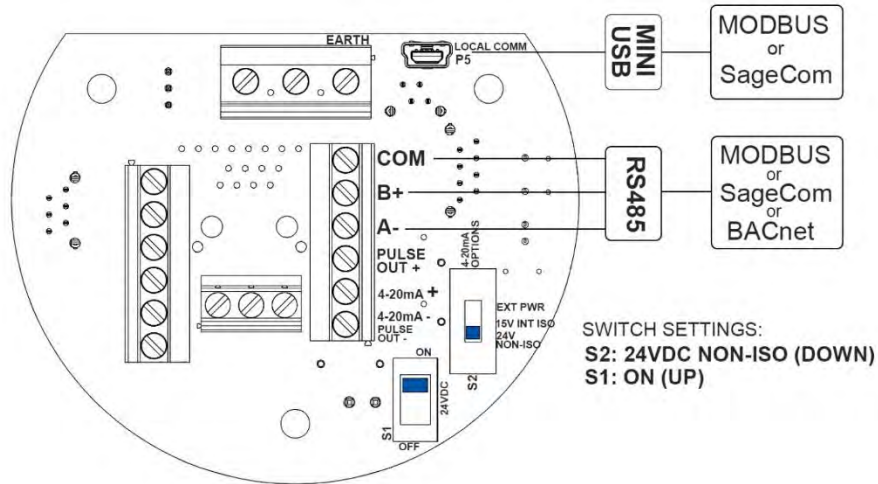

PARAMOUNT A1 08142019

24VDC POWERED 15VDC or 24VDC 4-20mA mA PULSE OUTPUT

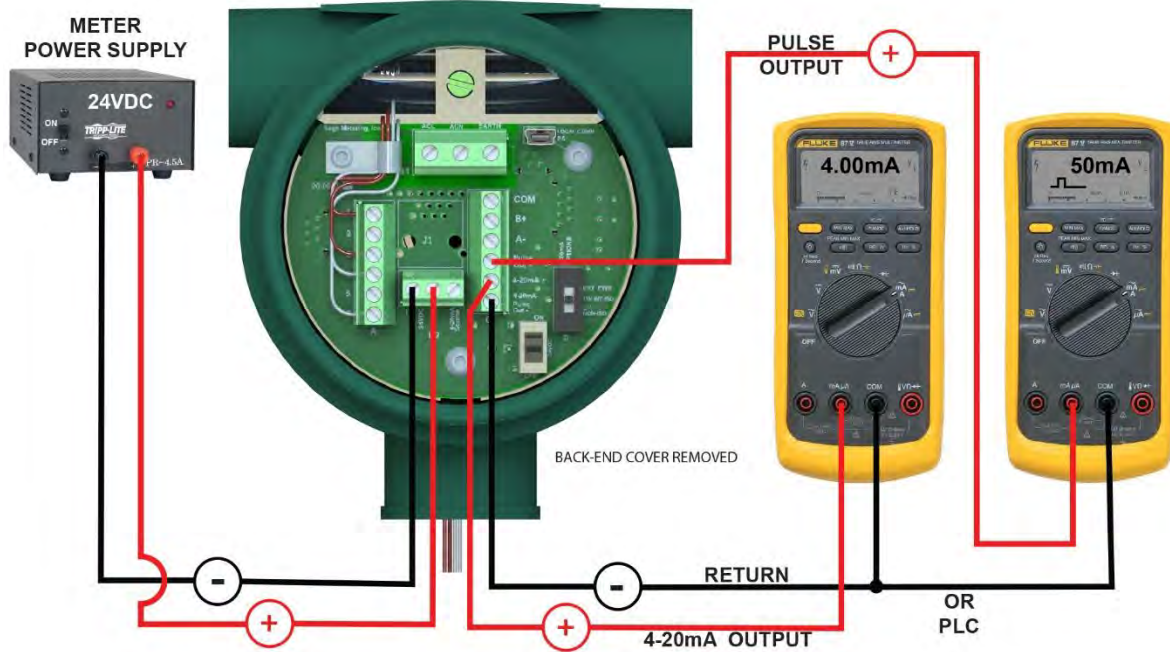
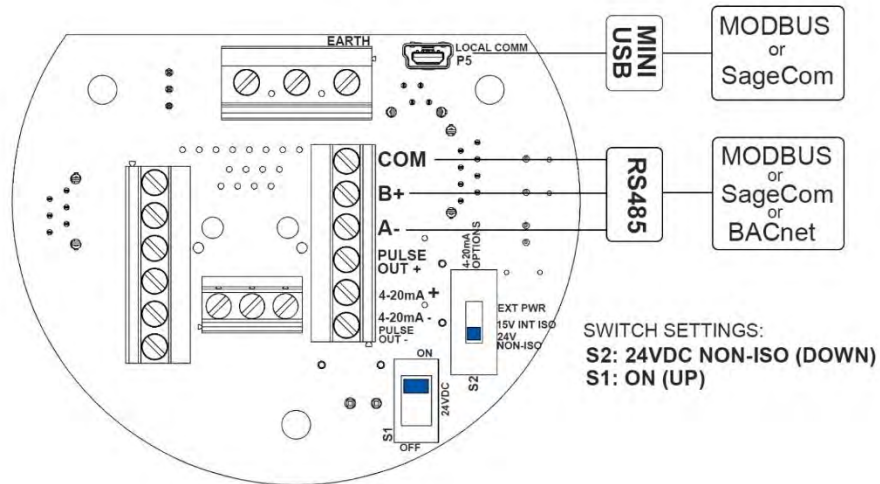

PARAMOUNT A2 08142019

**24VDC EXTERNALLY POWERED
12VDC - 24VDC 4-20mA
12VDC - 24VDC PULSE OUTPUT**

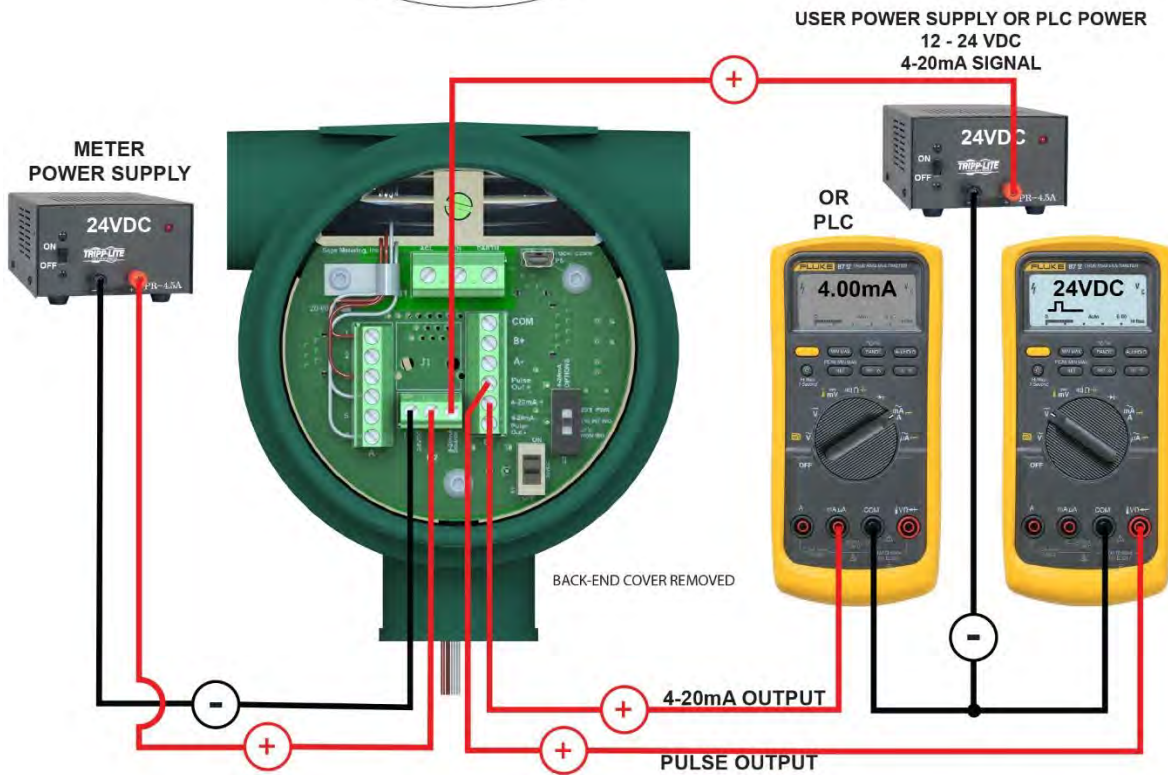
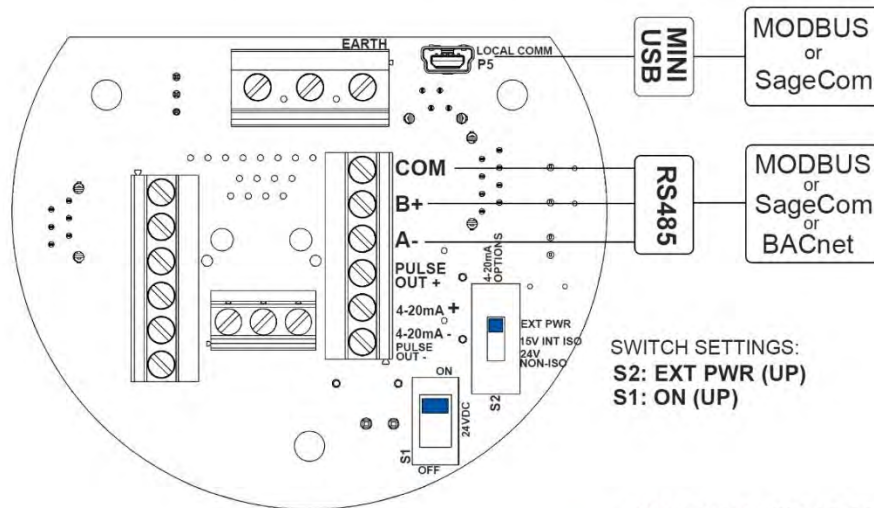

PARAMOUNT A3 08142019

24VDC EXTERNALLY POWERED 12VDC - 24VDC 4-20mA mA PULSE OUTPUT

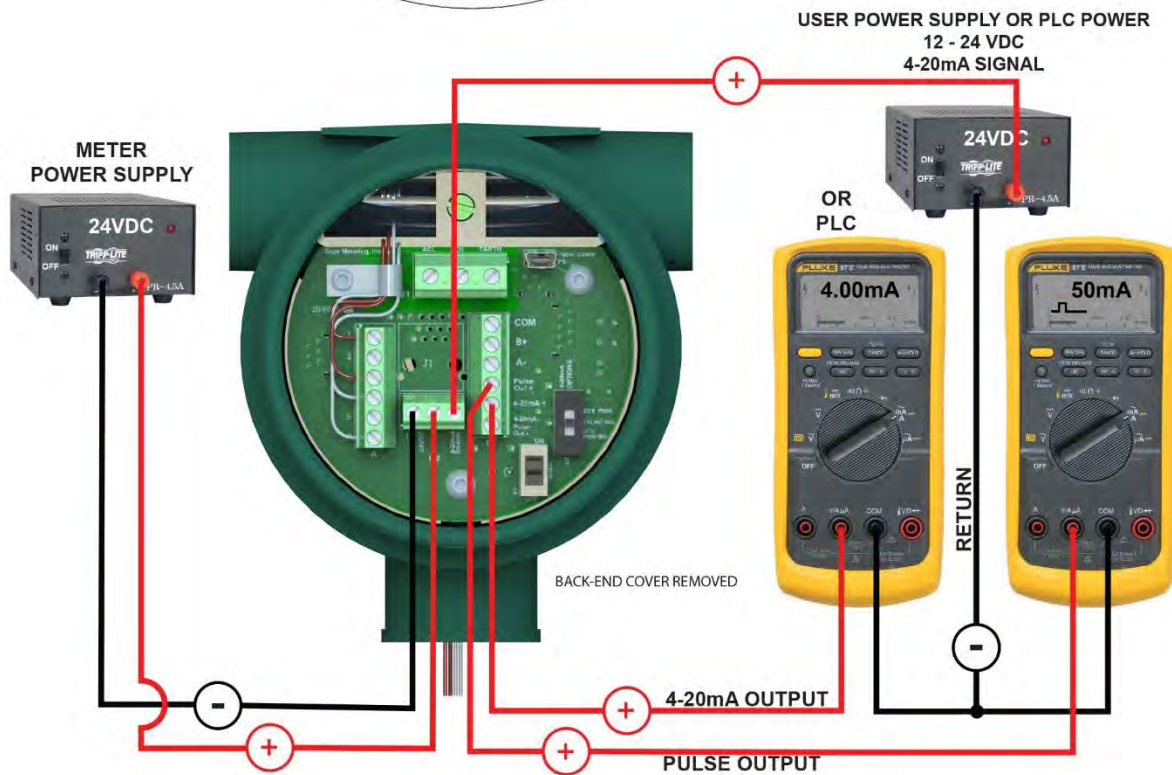
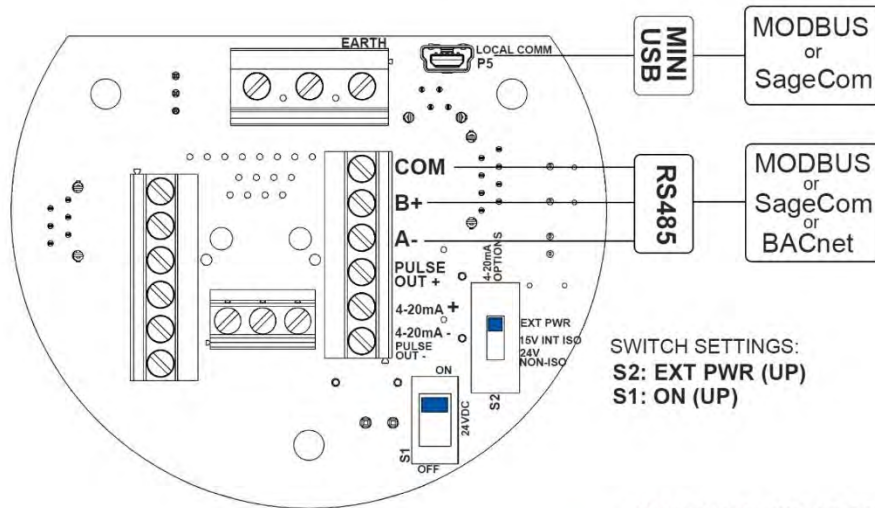

PARAMOUNT A4 08152019

110VAC POWERED 24VDC 4-20mA 24VDC PULSE OUTPUT

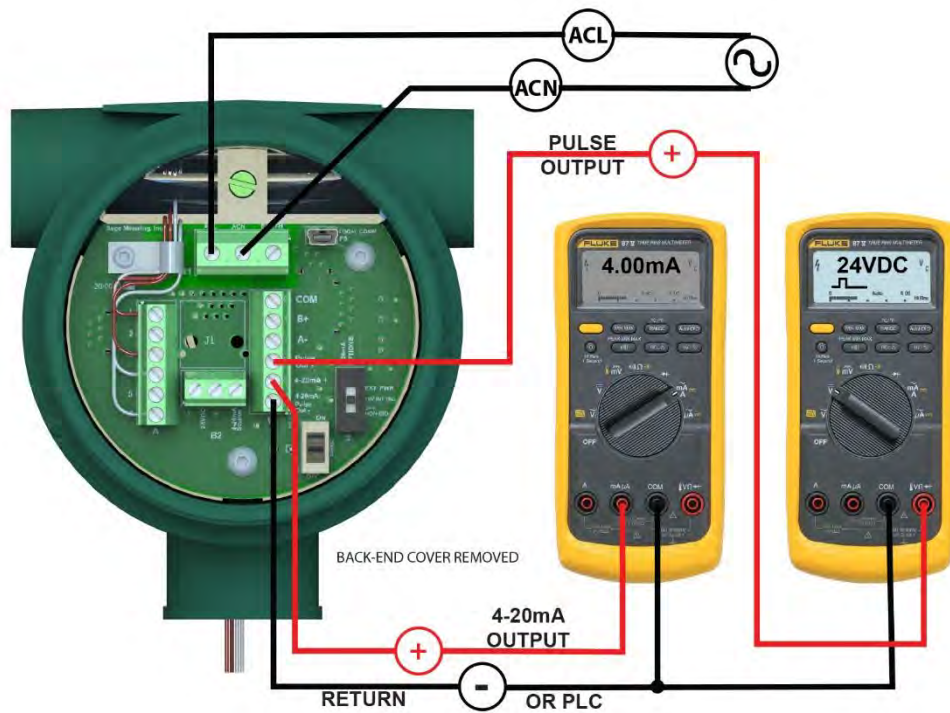
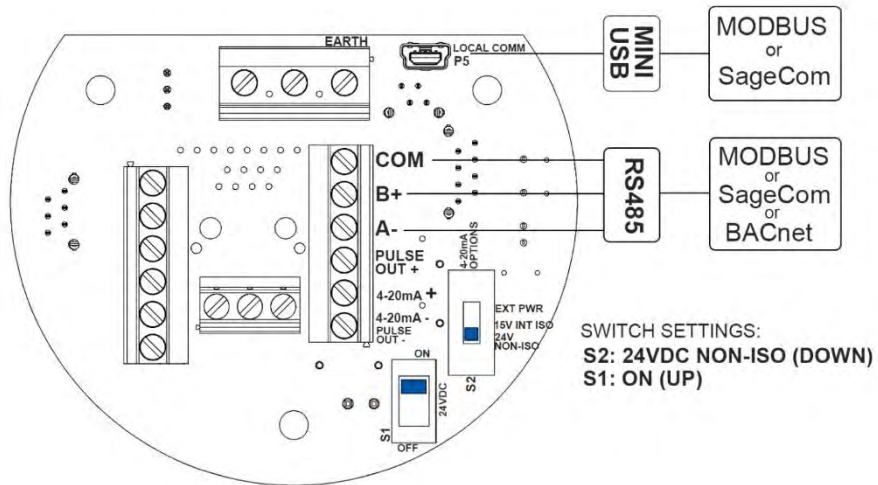

PARAMOUNT A5 08142019

**110VAC POWERED
24VDC 4-20mA
mA PULSE OUTPUT**

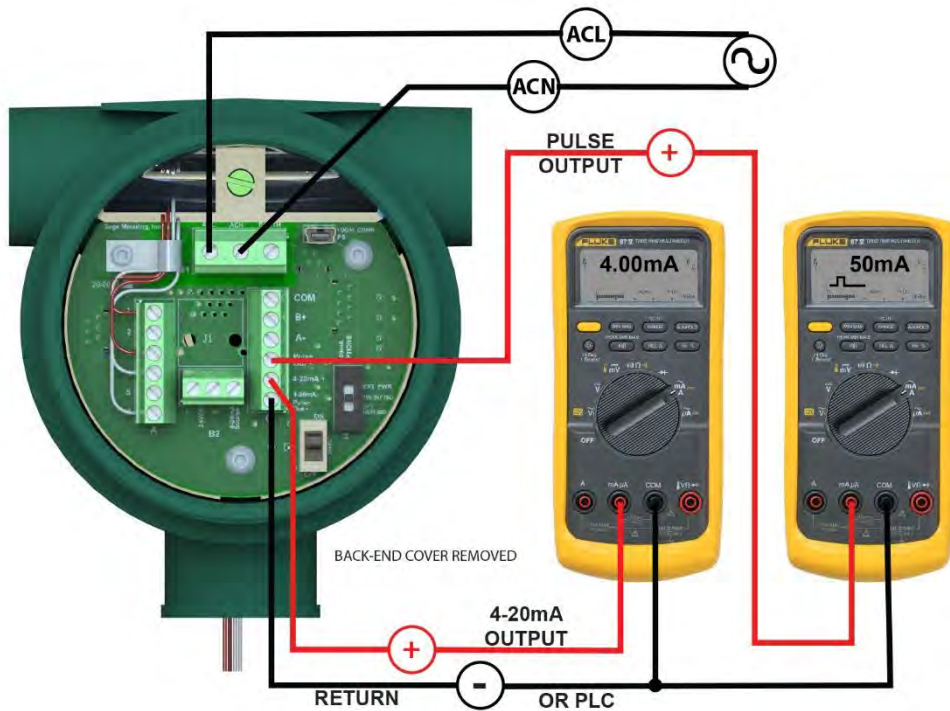
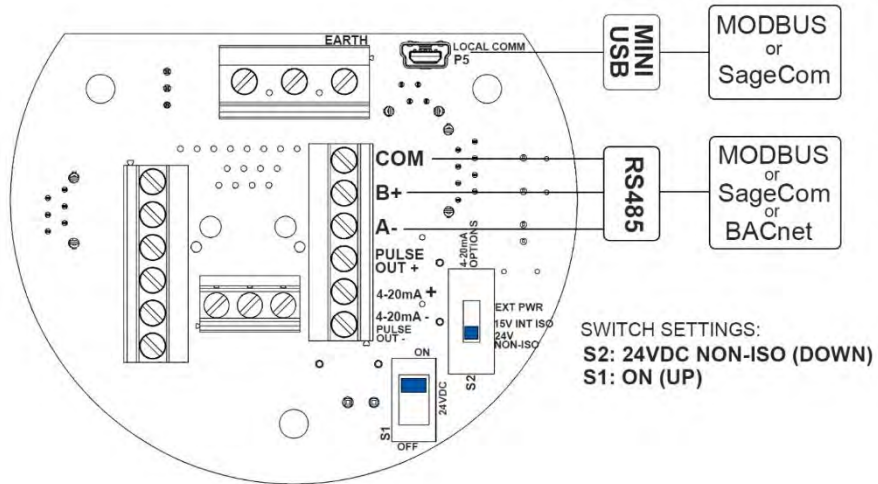

EXTERNALLY POWERED ISOLATED 12 - 24VDC HART ENABLED LOOP POWERED

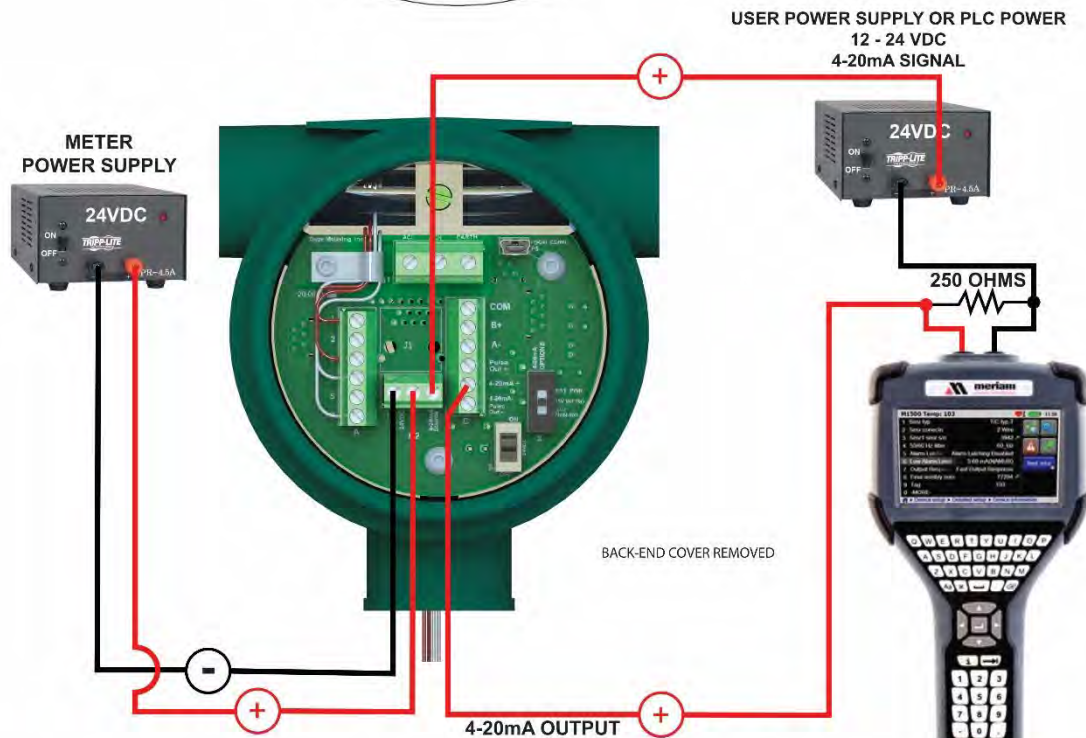
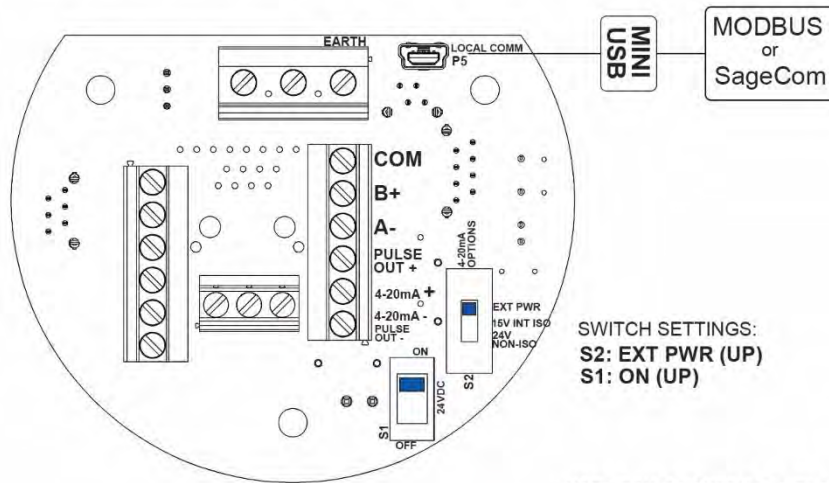

*The handheld HART Communicator shown is only one of many HART Modems available. Typically a Programmable Logic Controller (PLC) or Distributed Control System (DCS) will be used. Please note that additional devices on the HART 4-20mA line can impede HART Communication.

*HART COMMUNICATOR

24VDC ISOLATED HART ENABLED LOOP POWERED

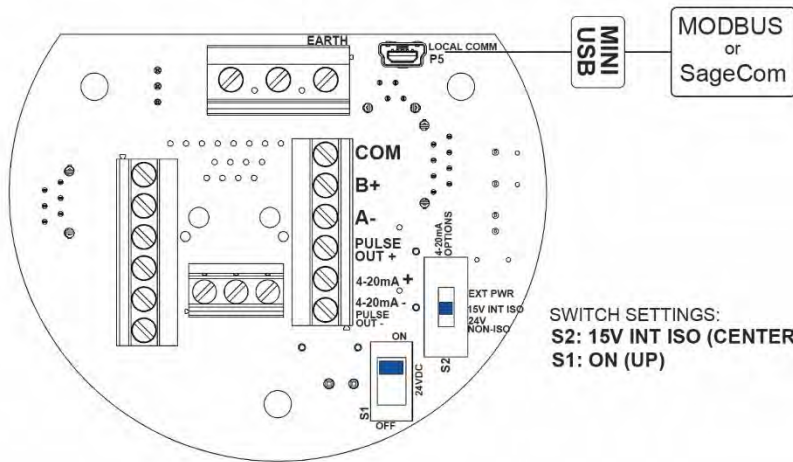

SWITCH SETTINGS:
S2: 15V INT ISO (CENTER)
S1: ON (UP)

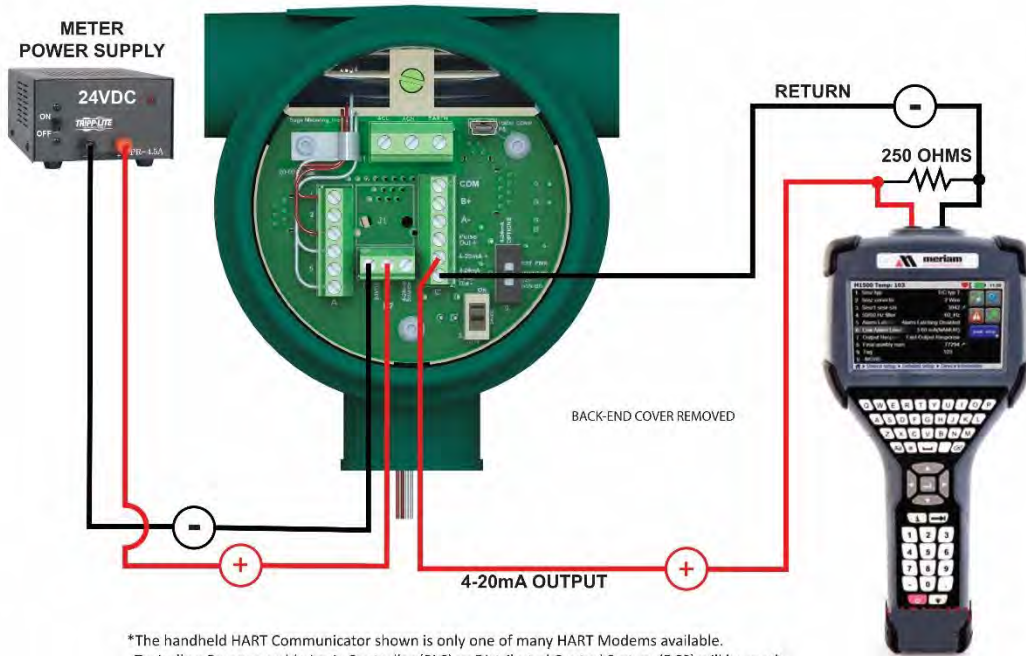

*The handheld HART Communicator shown is only one of many HART Modems available. Typically a Programmable Logic Controller (PLC) or Distributed Control System (DCS) will be used. Please note that additional devices on the HART 4-20mA line can impede HART Communication.

*HART COMMUNICATOR

110VAC ISOLATED HART ENABLED LOOP POWERED

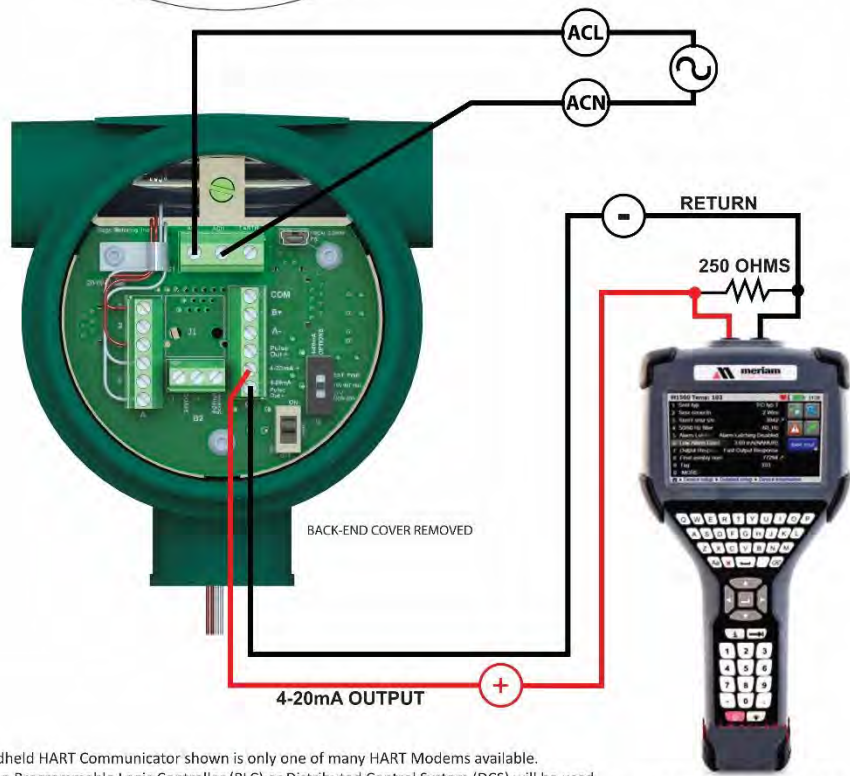
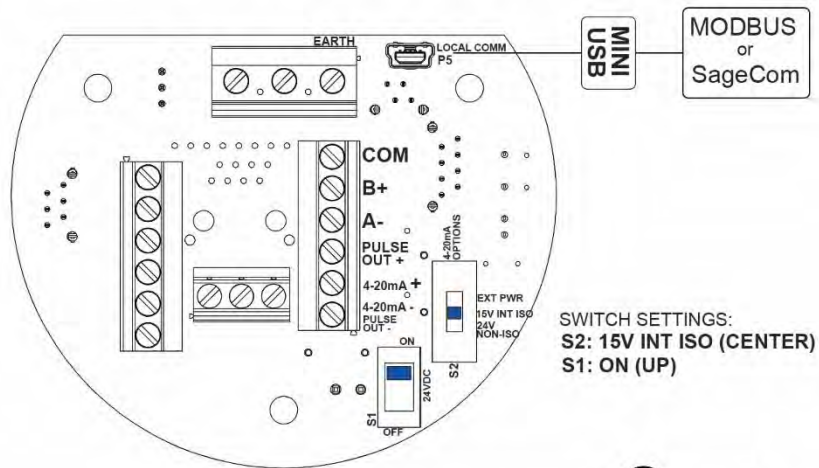

*The handheld HART Communicator shown is only one of many HART Modems available. Typically a Programmable Logic Controller (PLC) or Distributed Control System (DCS) will be used. Please note that additional devices on the HART 4-20mA line can impede HART Communication.

B10: Remote Cable Wiring Connections

REMOTE CABLE WIRING CONNECTIONS:

Use to connect Paramount Flow meter main electronics with Remote Sensor electronics

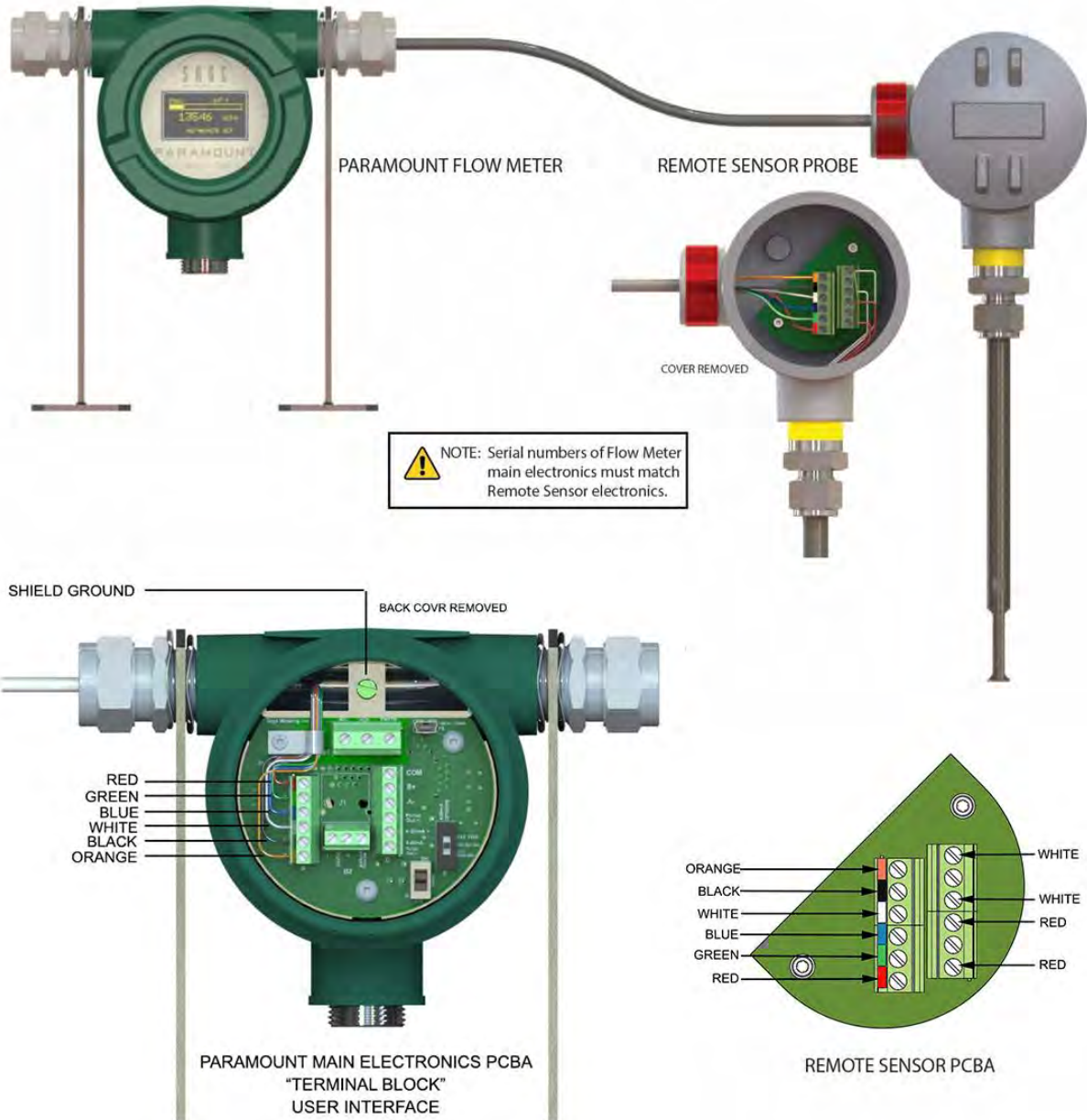

100-0376|90-0030 REV-A-|071719

WARNING: WIRE CONNECTIONS BETWEEN FLOW METER AND REMOTE SENSOR ARE INTENTIONALLY IN REVERSE ORDER; EXAMPLE, FLOW METER RED PIN 1 TO REMOTE SENSOR RED PIN 6

B11: REMOTE SENSOR OPTION HARDWARE INSTALLATION GUIDE

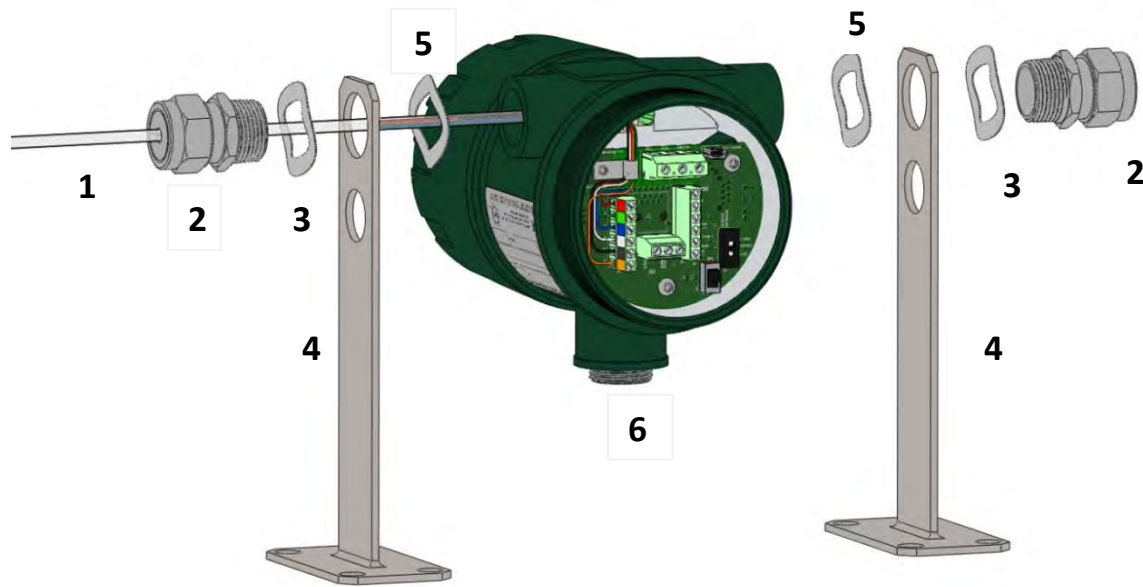

ITEM NUMBER	PART DESCRIPTION
1	25 FOOT CABLE (CORD) [CONNECTS REMOTE SENSOR TO PARAMOUNT METER] (SIX CONDUCTORS: RED-BLACK-WHITE-BLUE-GREEN-RED + SHIELD DRAIN WIRE)
2	CORD GRIP CONNECTOR, ¾ INCH HUB, 1/4 – 3/8 INCH DIA RANGE
3	WAVE WASHER
4	BRACKET
5	WAVE WASHER
6	THREADED PLUG, MANUFACTURE INSTALLED

INSTRUCTIONS:

- 1 ASSEMBLE THE HARDWARE COMPONENTS IN THE ORDER AS SHOWN FOR EACH PORT. TIGHTENED THE CABLE GRIP CONNECTOR (ITEM 2) USING THE THINNER NUT.
- 2 LOOSEN THE CORD GRIP GROMMETS BY TURNING THE LARGE NUT OF CORD GRIP CONNECTOR (ITEM 2). INSERT THE CABLE (ITEM 1) THROUGH CORD GRIP THRU HOLE. DO NOT THIGHTEN CORD GRIP NUT AT THIS TIME.
- 3 PASS CABLE THROUGH THE CORD GRIP UNTIL CABLE PASSES THROUGH THE METER PORT WITH AMPLE LEAD TO MAKE ELECTRICAL CONNECTIONS.
- 4 MAKE WIRE CONDUCTOR CONNECTIONS PER APPENDIX B10 (PREVIOUS PAGE).
- 5 GENTLY PULL ON CABLE BEHIND THE CORD GRIP CONNECTOR TO REDUCE CABLE SLACK IN THE METER.
- 6 ANGLE THE METER UP OR DOWN FOR BEST VIEW VIEWING POSITION. TIGHTEN CORD GRIP (LARGER NUT).
- 7 Hardware assembly is intended to be bolted onto a 2-inch pipe with U-bolts and nuts (NOT SUPPLIED WITH KIT).

APPENDIX C:

Modbus, BACnet, and Hart

C1: Modbus Register Map

Modbus Register Map				
Name	Data Type	Labview Address	Description	IEEE Address
format	int8	0	Format	256
unit_id	int8	1	Slave ID	256
mode2	int8	2	5 bits	257
noSaver	int8	2	1 bit	257
fix_pt	int8	2	2 bits	257
bRun	bit	3	1 bit	257
bTotal	bit	3	1 bit	257
bEEProm	bit	3	1 bit	257
bReset	bit	3	1 bit	257
htSAB	bit	3	1 bit	257
bLeadEn	bit	3	1 bit	257
bDAClo	bit	3	1 bit	257
bDAChi	bit	3	1 bit	257
bridge[0]	float	4	Injection value - mW	514
bridge[1]	float	8	k-factor	516
temp[0]	float	20	Temp Coeff A	522
temp[1]	float	24	Temp Coeff B	524
temp[2]	float	28	Temp Coeff C	526
temp[3]	float	32	Temp Coeff D	528
flow[0]	float	52	coeff A	538
flow[1]	float	56	coeff B	540
flow[2]	float	60	coeff C	542
flow[3]	float	64	coeff D	544
flow[4]	float	68	coeff E	546
flow[5]	float	72	coeff F	548
iir	float	76	Filter	550
flow_min	float	80	low flow cutoff	552
flow_max	float	84	Full Scale	554
temp_max	float	92	units per pulse	558
dac1_min	long	96	DAC min	302
dac1_max	long	98	DAC max	304
serial	int32	100	Serial number	306
eng_units[0][0]	int8	104	eng units	308
eng_units[0][1]	int8	105	eng units	308
eng_units[0][2]	int8	106	eng units	309

Name	Data Type	Labview Address	Description	IEEE Address
eng_units[0][3]	int8	106	eng units	309
eng_units[1][0]	int8	108	eng units	310
eng_units[1][1]	int8	109	eng units	310
eng_units[1][2]	int8	110	eng units	311
eng_units[1][3]	int8	111	temperature deg F or C	311
totalizer	int32	112	totalizer value	312
sil_flow	float	132	Flow Rate	578
sil_temp	float	136	temperature	580
rtd_mWatts	float	140	mW - active element	582
rtd_res	float	144	reference ohms + overheat ohms	584
ref_res_r	float	148	reference ohms	586
baud	hex	184	baud/parity	348
pulse_ms	int16	188-189	ms duration in ms	350
des1	int32	192-195	tag ID	352
des2	int32	196-199	tag ID	354
zero_flow	int16	200-201	zero flow mW	356
max_flow	int16	202-203	Full Scale mW	357
trip_total	int32	220-223	trip total	366
X_Section_Cust	float	232-235	Cross sectional area in ft ² - custom- er	372

C2: BACnet PICs



(3 pages)

Sage Metering BACnet PICs

BACnet Protocol Implementation Conformance Statement (PICS)

Date: May 6, 2019
 Product Names: Sage Paramount / Sage Prime
 Applications Software Version: V4.100
 Firmware Revision: V4.100
 BACnet Protocol Revision: 12

BACnet Standard Device Profile (Annex L):

- BACnet Operator Workstation (B-OWS)
- BACnet Building Controller (B-BC)
- BACnet Advanced Application Controller (B-AAC)
- BACnet Application Specific Controller (B-ASC)
- BACnet Smart Sensor (B-SS)
- BACnet Smart Actuator (B-SA)

BACnet Interoperability Building Blocks Supported (Annex K):

- Data Sharing – ReadProperty-B (DS-RP-B)
- Data Sharing – ReadPropertyMultiple-B (DS-RPM-B)
- Data Sharing – WriteProperty-B (DS-WP-B)
- Data Sharing – WritePropertyMultiple-B (DS-WPM-B)
- Data Sharing – COV-B (DS-COV-B)
- Device Management – Dynamic Device Binding-B (DM-DDB-B)
- Device Management – Dynamic Object Binding-B (DM-DOB-B)
- Device Management – DeviceCommunicationControl-B (DM-DCC-B)
- Device Management – ReinitializeDevice-B (DM-RD-B)

Segmentation Capability:

- Able to transmit segmented messages Window Size _____
- Able to receive segmented messages Window Size _____

Standard Object Types Supported:

Property	Object Type		
	Device	Analog Input	Analog Value
Object Identifier	W	R	R
Object Name	W	R	R
Object Type	R	R	R
System Status	R		
Vendor Name	R		
Vendor Identifier	R		
Model Name	R		
Firmware Revision	R		
App Software Revision	R		
Protocol Version	R		
Protocol Revision	R		
Services Supported	R		
Object Types Supported	R		
Object List	R		
Max APDU Length	R		
Segmentation Support	R		
APDU Timeout	W (10...65535)		
Number APDU Retries	W (0...10)		
Max Master	W (1...127)		
Max Info Frames	W (1...100)		
Device Address Binding	R		
Database Revision	R		
Active COV Subscriptions	R		
Present Value		R	W
Status Flags		R	R
Event State		R	R
Reliability		R	R
Out-of-Service		R	R
Units		R	R
Priority Array			R
Relinquish Default			R
COV Increment		W	W

R – Readable using BACnet services

W – Readable and writable using BACnet services

Data Link Layer Options:

- BACnet IP, (Annex J)
- BACnet IP, (Annex J), Foreign Device
- ISO 8802-3, Ethernet (Clause 7)
- ANSI/ATA 878.1, 2.5 Mb. ARCNET (Clause 8)
- ANSI/ATA 878.1, RS-485 ARCNET (Clause 8), baud rate(s) _____
- MS/TP master (Clause 9), baud rate(s): 9600, 19200, 38400, 57600, 76800, 115200
- MS/TP slave (Clause 9), baud rate(s): _____
- Point-To-Point, EIA 232 (Clause 10), baud rate(s): _____
- Point-To-Point, modem, (Clause 10), baud rate(s): _____
- LonTalk, (Clause 11), medium: _____
- Other: _____

Device Address Binding:

Is static device binding supported? (This is currently for two-way communication with MS/TP slaves and certain other devices.) Yes No

Networking Options:

- Router, Clause 6 - List all routing configurations
- Annex H, BACnet Tunneling Router over IP
- BACnet/IP Broadcast Management Device (BBMD)
 - Does the BBMD support registrations by Foreign Devices? Yes No

Network Security Options:

- Non-secure Device - is capable of operating without BACnet Network Security
- Secure Device - is capable of using BACnet Network Security (NS-SD BIBB)
 - Multiple Application-Specific Keys:
 - Supports encryption (NS-ED BIBB)
 - Key Server (NS-KS BIBB)

Character Sets Supported:

Indicating support for multiple character sets does not imply that they can all be supported simultaneously.

- ISO 10646 (UTF-8)
- JIS X 0208
- ISO 10646 (UCS-4)
- IBM™/Microsoft™ DBCS
- ISO 10646 (UCS-2)
- ISO 8859-1

C3: HART Fast Keys

Primary Variable—Read Only

Provides information regarding the Primary Variable (Flow)

PV Measurements

Flow Rate [Fast Key 1,1,1,1]

The actual measurement of the flow rate in the reference unit of measurement

PV Loop Current [Fast Key 1,1,1,2]

Analog value output ranging between 4 and 20 mA representing the flow rate. The 4 and 20 mA loop can be verified by using the Loop Test described below in the Diagnostic section [Fast Key 2,3,1].

PV % of Range [Fast Key 1,1,1,3]

Provides the value of the flow rate representing the % of the range between the LRV (Lower Range Value) and the URV (Upper Range Value)

Flow Rate Units [Fast Key 1,1,1,4]

Units of measurement associated with the flow rate.

Flow Rate Parameters

Low Flow Cutoff [Fast Key 1,1,2,1]

Any measured flow rate below this value is set to 0.

PV URV [Fast Key 1,1,2,2]

Upper Range Value of the Primary Variable. Represents the 20-mA value

PV LRV [Fast Key 1,1,2,3]

Lower Range Value of the Primary Variable (represents the 4-mA value). Value is 0.

PV Damping [Fast Key 1,1,2,4]

Primary Variable Damping factor. Used to smooth out normal occurring fluctuations in the flow rate.

K Factor [Fast Key 1,1,2,5]

K Factor is a linear adjustment factor which may be used to adjust the flow rate for various reasons requested by the user. Default is 1.

Dynamic Variables

Flow Rate [Fast Key 1,1,3,1]

Displays the current flow rate measured by the flow meter

Total [Fast Key 1,1,3,2]

Displays the total flow measured by the instrument

RTD Power [Fast Key 1,1,3,3]

Measurement of the power in mW corresponding to the measured flow rate. Useful for diagnostic purposes

Temperature [Fast Key 1,1,3,4]

Displays the gas temperature where the sensor is located

Flow Rate Units [Fast Key 1,1,3,5]

Units of measurement of the flow rate

Total Units [Fast Key 1,1,3,6]

Units of measurement of the total flow

Loop Current Bar Graph [Fast Key 1,1,4]

Displays a graphic chart showing the mA output of the flow rate vs. time – Range between 4 and 20 mA

Percent Range Bar Graph

Displays a graphic chart showing the flow rate as a % of the range between the LRV and URV

Dynamic Variables Chart

Displays a graphic chart showing flow rate in selected units of measurement vs. time

HART Identification**Tag** [Fast Key 1,2,1]

A Tag value entered by the user to identify the flow meter. Up to 8 digits in length

Long Tag [Fast Key 1,2,2]

A value entered by the user

Manufacturer [Fast Key 1,2,3]

The name of the Manufacturer of the flow meter. In this case, it is Sage Metering

Model [Fast Key 1,2,4]

Manufacturer's model number of the flow meter.

Device Id [Fast Key 1,2,5]

Factory entered number which is unique for each instrument

Diagnostics**Device Status** [Fast Key 2,1]

Will indicate any standard diagnostics message

Sensor Status**Flow Below Cutoff** [Fast Key 2,2,1]

Diagnostics menu indicating that the measured flow rate is less than the low flow cutoff

Loop Diagnostics**Loop Test** [Fast Key 2,3,1]

Permits the user to drive the mA output to the desired value.

D/A Trim [Fast Key 2,3,2]

Used to calibrate the 4–20 mA output from the flow meter to match the system loop.

Flow Test [Fast Key 2,3,3]

Permits user to enter a value for the RTD Power with the display showing expected flow rate based on original calibration. Use the full diagnostics test to ensure that the flow meter is matching the original calibration curve.

Device Setup**Basic Setup****K Factor** [Fast Key 3,1,1]

Enter a K factor which provides a linear adjustment of the flow rate. May be used to correct for different pipe size, varying gas composition, or installation effects which change the performance of the flow meter.

PV Damping [Fast Key 3,1,2]

Provides smoothing of normally occurring flow fluctuations (value between 0.001 to 0.999); the lower the value providing greater smoothing (time averaging).

Low Flow Cutoff [Fast Key 3,1,3]

Enter a minimum value of the flow rate. Flow rates measured below this value shown as zero flow. Useful to disregard any false readings which might occur during a no-flow condition

Flow Rate Units [Fast Key 3,1,4]

Units of measurement of the flow rate (a text entry). Any change in units of measurement from original calibration must also apply a K factor

Temperature Units [Fast Key 3,1,5]

Displays the units of measurement of the gas temperature

Total Units [Fast Key 3,1,6]

Four-digit entry. The first three digits represent the units of measurements of total flow, and the fourth digit is “C” or “F” to identify units of measurement of the temperature reading.

Output**Analog Output****PV URV** [Fast Key 3,2,1,1]

Enter the Upper Range Value for the Primary Variable (flow rate). The URV must be in the identified units of measurement and must be within the calibration range of the instrument. Consult Sage Metering if assistance is required.

Totalizer**Total Units** [Fast Key 3,2,2,1]

Displays the units of measurement for the totalized value

Total [Fast Key 3,2,2,2]

Displays the totalized value in the selected units of measurement

Pulse Output**Pulse Count** [Fast Key 3,2,3,1]

Provides the number of units per pulse (e.g., a Pulse Count of 100 and units set to SCF, then one pulse is equivalent to 100 SCF)

Pulse Duration [Fast Key 3,2,3,2]

To be finalized

HART**Poll Address** [Fast Key 3,2,4,1]

Used multi-drop installations to identify an individual instrument. Values can range between 1 and 15. If used in a multi-drop configuration the 4–20mA output is set to 4 mA. The default setting is a Poll Address = 0 with the 4–20 mA analog signal operational.

Loop Current Mode [Fast Key 3,2,4,2]

Allows the user to select whether the loop current is enabled (active) or disabled (fixed at 4mA) regardless of the poll address setting.

Number of Request Preambles [Fast Key 3,2,4,3]

Required HART command – indicates the number of preambles required by the instrument for HART communication.

Device Information**Tag** [Fast Key 3,3,1]

Enter an 8-digit tag which can be used to identify the instrument

Long Tag [Fast Key 3,3,2]

Enter up to a 32-digit tag which can be used for any purpose desired by the user.

Descriptor [Fast Key 3,3,3]

A 16-character entry which can be used for additional identification of the instrument.

Message [Fast Key 3,3,4]

A 32-character entry which can be used for identification or other purposes.

Date [Fast Key 3,3,5]

Enter date code is often used to enter the last date a configuration change was made.

Meter S/N [Fast Key 3,3,6]

Factory entry of the serial number of the instrument

Final Assembly Num [Fast Key 3,3,7]

Factory entered identification which may be used for future reference

Revisions:

- **Universal Revision Number** [Fast key 3,3,8,1]
Identifies the HART specification used in the design of the instrument
- **Field Device Revision Number** [Fast Key 3,3,8,2]
Provides the instrument revision for HART compatibility
- **Software Revision Level** [Fast Key 3,3,8,3]
Provides the software revision used by the instrument
- **Hardware Revision Level** [Fast Key 3,3,8,4]
Provides the Hardware revision level of the instrument

Factory

Flow Factors and TC Factors
Displays factory entered calibration values for the instrument