



OPTIBAR DP 7060 Handbook

Differential pressure transmitter for measuring flow, level, differential pressure, density and interface

2-wire 4...20 mA HART: ER: from 1.02._; SW: from 1.2.2; HW: from 1.0.1

2-wire 4...20 mA HART with SIL 2/3: ER: 1.02._; SW: from 1.2.2; HW: 1.0.0

All rights reserved. It is prohibited to reproduce this documentation, or any part thereof, without the prior written authorisation of KROHNE Messtechnik GmbH.

Subject to change without notice.

Copyright 2023 by
KROHNE Messtechnik GmbH - Ludwig-Krohne-Str. 5 - 47058 Duisburg (Germany)

1	Safety instructions	6
1.1	Software history	6
1.2	Intended use	7
1.3	Technical limits	8
1.4	Measured products.....	8
1.5	Manufacturer's declaration.....	8
1.6	Safety instructions from the manufacturer	9
1.6.1	Copyright and data protection	9
1.6.2	Disclaimer.....	9
1.6.3	Product liability and warranty	9
1.6.4	Information concerning the documentation.....	10
1.6.5	Warnings and symbols used.....	10
1.7	Safety instructions for the operator	11
2	Device description	12
2.1	Scope of delivery.....	12
2.2	Device description	13
2.2.1	Device design	13
2.2.2	Connection variants	14
2.3	Nameplates	15
2.4	Terms and abbreviations.....	16
3	Installation	17
3.1	General notes on installation	17
3.2	Ingress protection for housing.....	17
3.3	Packaging	17
3.4	Storage	18
3.5	Transport	18
3.6	Installation specifications	18
3.7	Mounting.....	19
3.7.1	Rotating the housing.....	19
3.7.2	Mounting the display and adjustment module.....	20
3.7.3	Process connections.....	21
3.7.4	Mounting bracket.....	22
3.7.5	Manifolds.....	23
3.7.6	Differential pressure transmitter.....	23
3.7.7	Pressure connection with impulse line.....	23
3.7.8	Vibrations	24
3.7.9	Temperature limits.....	24
3.8	Instructions for oxygen applications.....	24
3.9	Venting	25
3.10	Measurement setup for flow measurement	26
3.10.1	In gases and liquids with solids content.....	26
3.10.2	In vapours and pure liquids	27
3.11	Measurement setup for level measurement	28
3.11.1	In open vessels with impulse line.....	28
3.11.2	In closed vessels with gas-filled impulse lines.....	29
3.11.3	In closed vessels with liquid / condensate filled impulse lines.....	30

4	Electrical connections	31
4.1	Safety instructions	31
4.2	Notes for electrical cables	31
4.2.1	Requirements for signal cables supplied by the customer	32
4.2.2	Laying electrical cables correctly	32
4.2.3	Cable preparation	33
4.2.4	Cable entry 1/2-14 NPT (female)	34
4.2.5	Connector pin assignment	34
4.2.6	Connection to the power supply	35
4.2.7	Cable shield and grounding	36
4.3	Electrical connection	36
4.3.1	Connection in the terminal compartment	36
4.3.2	Single chamber housing	37
4.3.3	Double chamber housing	38
4.4	Grounding the measuring device	39
4.5	Description of the current output	39
5	Start-up	40
5.1	Commissioning	40
5.2	Keypad functions	41
5.3	Set up Bluetooth connection with smartphone/tablet	42
5.4	Quick set-up	43
5.4.1	Adjustment differential pressure	44
5.4.2	Adjustment level	44
5.4.3	Adjustment flow	45
5.4.4	Adjustment density	45
5.5	Extended adjustment	46
5.5.1	Start-up	46
5.5.2	Display	48
5.5.3	Diagnosis	49
5.5.4	Additional adjustments	50
5.5.5	Info	51
5.6	Reset	51
5.6.1	Delivery status	51
5.6.2	Basic settings	51
5.7	Saving the device settings	52
5.7.1	Copy device settings	52
5.8	Diagnosis memory	53
5.9	Failures and diagnostics	54
5.9.1	Advanced Error codes	55
5.9.2	Check 4...20 mA signal	57
5.9.3	Error messages via the display and operating module	57
6	Service	58
6.1	Replacement	58
6.1.1	Change electronic insert	58
6.1.2	Replace the pressure caps	59
6.2	Software update	60

6.3	Maintenance	61
6.4	Spare parts availability	61
6.5	Availability of services	61
6.6	Repairs.....	61
6.7	Returning the device to the manufacturer.....	61
6.7.1	General information.....	61
6.7.2	Form (for copying) to accompany a returned device.....	63
6.8	Disposal	63
6.9	Digital sensor trim.....	64
6.9.1	Digital sensor trim via the display and adjustment module	64
6.9.2	Digital sensor trim via the KROHNE DTM	65
7	Technical data	66
7.1	Measuring principle.....	66
7.2	Technical data.....	67
7.3	Pressure ranges	75
7.4	Ambient temperature effect on current output	76
7.5	Dynamic behaviour of the current output	77
7.6	Dimensions and weight	78
8	Description of HART interface	92
8.1	General description	92
8.2	Software history	92
8.3	Connection variants.....	93
8.3.1	Point-to-Point connection - analogue / digital mode.....	93
8.4	Inputs / Outputs and HART® dynamic variables and device variables.....	94
8.5	Field Communicator 475 (FC 475).....	94
8.5.1	Installation	94
8.5.2	Operation.....	94
8.6	Field Device Tool / Device Type Manager (FDT / DTM)	94
8.6.1	Installation	94

1.1 Software history

The "Electronic Revision" (ER) is consulted to document the revision status of the electronics according to NE 53. It is easy to see from the ER whether troubleshooting or larger changes in the electronic equipment have taken place and how that has affected the compatibility.

Changes and effect on compatibility

1	Downwards compatible changes and fault repair with no effect on operation (e.g. spelling mistakes on display)	
2- _	Downwards compatible hardware and/or software change of interfaces:	
	H	HART®
	P	PROFIBUS
	F	Foundation Fieldbus
	M	Modbus
X	all interfaces	
3- _	Downwards compatible hardware and/or software change of inputs and outputs:	
	I	Current output
	F, P	Frequency / pulse output
	S	Status output
	C	Control input
	CI	Current input
X	All inputs and outputs	
4	Downwards compatible changes with new functions	
5	Incompatible changes, i.e. electronic equipment must be changed.	



INFORMATION!

In the table below, "x" is a placeholder for possible multi-digit alphanumeric combinations, depending on the available version.

Release date	Revisions	Changes and compatibility	Documentation
2014-04-01	ER: 1.01._ SW: 1.0.0 HW: 1.0.0	-	MA OPTIBAR DP 7060 R01
2014-11-01	ER: 1.01._ SW: 1.1.2 HW: 1.0.0	1; 3-I; 4:	MA OPTIBAR DP 7060 R02
2014-11-01	ER: 1.01._ SW: 1.1.2 HW: 1.0.1	1;	MA OPTIBAR DP 7060 R03
2015-11-09	ER: 1.01._ SW: 1.2.2 HW: 1.0.1	1, 2-H, 4	MA OPTIBAR DP 7060 R04
2016-01-01	ER: 1.02._ SW: 1.3.0 HW: 1.0.1	1, 2-H, 4	MA OPTIBAR DP 7060 R05
2018-11-27	ER: 1.02._ SW: 1.3.4 HW: 1.0.1	1, 2-H, 3-I	MA OPTIBAR DP 7060 R06

1.2 Intended use

**DANGER!**

For devices used in hazardous areas, additional safety notes apply.

**CAUTION!**

Responsibility for the use of the measuring devices with regard to suitability, intended use and corrosion resistance of the used materials against the measured fluid lies solely with the operator.

**INFORMATION!**

This device is a Group 1, Class A device as specified within CISPR11. It is intended for use in industrial environment. There may be potential difficulties in ensuring electromagnetic compatibility in other environments, due to conducted as well as radiated disturbances.

**INFORMATION!**

The manufacturer is not liable for any damage resulting from improper use or use for other than the intended purpose.

The OPTIBAR DP 7060 is a differential pressure transmitter suitable for measuring flow, level, differential pressure, density and interface of gases, vapours and liquids. The available measurement ranges and the respective permissible overloads are indicated on the nameplate. To observe the intended use, adhere to the following points:

- Observe the instructions in this document.
- Comply with the technical specifications (for further information refer to *Technical data* on page 67).
- Only suitably qualified personnel may install and operate the device.
- Observe the generally accepted standards of good practice.

**CAUTION!**

- *Any modification to the device, including drilling, sawing, trimming, welding and soldering of parts, or partially painting over or coating, is prohibited.*
- *Neither is it permitted to use the device as a climbing aid e.g. for installation purposes, as a holder for cables, pipes or other loads.*
- *The mounting or installation of parts is only permitted as described in this document, or insofar as it has been authorised by the manufacturer or a certified service partner.*

1.3 Technical limits

The device was constructed solely for use within the technical limits indicated on the nameplate and in the technical data. Applications outside of these limits are not permitted and could lead to significant risk of accident. For this reason, observe the following limits:

- Do not exceed the maximum working pressure (MWP).
- Do not exceed the indicated permissible operating temperature range.
- The permissible ambient temperatures given may not be exceeded or undershot.
- Check the materials used for the wetted parts (e.g. gasket, process connection, separating diaphragm etc.) for suitability as regards process compatibility.

1.4 Measured products

The device is designed to measure the pressure of vaporous, gaseous and liquid media. Prior to using any corrosive or abrasive products, the operator must check the resistance of all materials which are in contact with the product.

1.5 Manufacturer's declaration

CE marking



The device meets the essential requirements of the EU directives. The CE marking indicates the conformity of the product with the union legislation applying to the product and providing for CE marking.

For full information of the EU directives and standards and the approved certifications, please refer to the EU declaration on the KROHNE website.

Radio licenses for display and adjustment modul with Bluetooth

The radio module used in the instrument for wireless Bluetooth communication is approved for use in countries of the EU and EFTA. It was tested by the manufacturer according to the latest edition of the following standard:

- EN 300 328 – Wideband transmission systems

The radio module used in the instrument for wireless Bluetooth communication has also radio licenses for the USA and Canada applied for by the manufacturer:

- USA - FCC ID: P14BL600
- Canada - IC: 1931B-BL600

1.6 Safety instructions from the manufacturer

1.6.1 Copyright and data protection

The contents of this document have been created with great care. Nevertheless, we provide no guarantee that the contents are correct, complete or up-to-date.

The contents and works in this document are subject to copyright. Contributions from third parties are identified as such. Reproduction, processing, dissemination and any type of use beyond what is permitted under copyright requires written authorisation from the respective author and/or the manufacturer.

The manufacturer tries always to observe the copyrights of others, and to draw on works created in-house or works in the public domain.

The collection of personal data (such as names, street addresses or e-mail addresses) in the manufacturer's documents is always on a voluntary basis whenever possible. Whenever feasible, it is always possible to make use of the offerings and services without providing any personal data.

We draw your attention to the fact that data transmission over the Internet (e.g. when communicating by e-mail) may involve gaps in security. It is not possible to protect such data completely against access by third parties.

We hereby expressly prohibit the use of the contact data published as part of our duty to publish an imprint for the purpose of sending us any advertising or informational materials that we have not expressly requested.

1.6.2 Disclaimer

The manufacturer will not be liable for any damage of any kind by using its product, including, but not limited to direct, indirect or incidental and consequential damages.

This disclaimer does not apply in case the manufacturer has acted on purpose or with gross negligence. In the event any applicable law does not allow such limitations on implied warranties or the exclusion of limitation of certain damages, you may, if such law applies to you, not be subject to some or all of the above disclaimer, exclusions or limitations.

Any product purchased from the manufacturer is warranted in accordance with the relevant product documentation and our Terms and Conditions of Sale.

The manufacturer reserves the right to alter the content of its documents, including this disclaimer in any way, at any time, for any reason, without prior notification, and will not be liable in any way for possible consequences of such changes.

1.6.3 Product liability and warranty

The operator shall bear responsibility for the suitability of the device for the specific purpose. The manufacturer accepts no liability for the consequences of misuse by the operator. Improper installation or operation of the devices (systems) will cause the warranty to be void. The respective "Standard Terms and Conditions" which form the basis for the sales contract shall also apply.

1.6.4 Information concerning the documentation

To prevent any injury to the user or damage to the device it is essential that you read the information in this document and observe applicable national standards, safety requirements and accident prevention regulations.

If this document is not in your native language and if you have any problems understanding the text, we advise you to contact your local office for assistance. The manufacturer cannot accept responsibility for any damage or injury caused by misunderstanding of the information in this document.

This document is provided to help you establish operating conditions, which will permit safe and efficient use of this device. Special considerations and precautions are also described in the document, which appear in the form of icons as shown below.

1.6.5 Warnings and symbols used

Safety warnings are indicated by the following symbols.



DANGER!

This warning refers to the immediate danger when working with electricity.



DANGER!

This warning refers to the immediate danger of burns caused by heat or hot surfaces.



DANGER!

This warning refers to the immediate danger when using this device in a hazardous atmosphere.



DANGER!

These warnings must be observed without fail. Even partial disregard of this warning can lead to serious health problems and even death. There is also the risk of seriously damaging the device or parts of the operator's plant.



WARNING!

Disregarding this safety warning, even if only in part, poses the risk of serious health problems. There is also the risk of damaging the device or parts of the operator's plant.



CAUTION!

Disregarding these instructions can result in damage to the device or to parts of the operator's plant.



INFORMATION!

These instructions contain important information for the handling of the device.



LEGAL NOTICE!

This note contains information on statutory directives and standards.



- **HANDLING**

This symbol designates all instructions for actions to be carried out by the operator in the specified sequence.

- ➔ **RESULT**

This symbol refers to all important consequences of the previous actions.

1.7 Safety instructions for the operator



WARNING!

In general, devices from the manufacturer may only be installed, commissioned, operated and maintained by properly trained and authorized personnel.

This document is provided to help you establish operating conditions, which will permit safe and efficient use of this device.

2.1 Scope of delivery

**INFORMATION!**

Inspect the packaging carefully for damages or signs of rough handling. Report damage to the carrier and to the local office of the manufacturer.

**INFORMATION!**

Do a check of the packing list to make sure that you have all the elements given in the order.

**INFORMATION!**

Look at the device nameplate to ensure that the device is delivered according to your order. Check for the correct supply voltage printed on the nameplate.

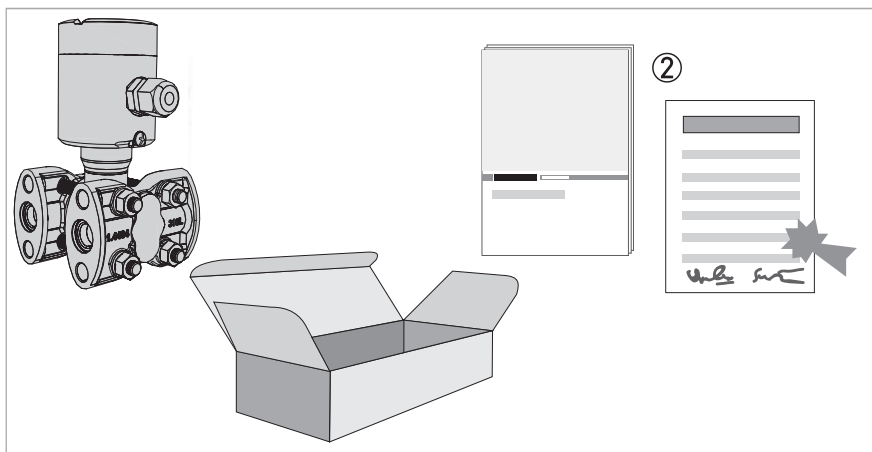

Figure 2-1: Scope of delivery

- ① Device in the version as ordered
- ② Documentation (test reports, factory and material certification (if ordered) and product documentation)

Optional accessories

- Oval flange adapter 1/2-14 NPT (female)
- Manifolds
- Sealings
- Mounting bracket

**INFORMATION!**

Assembly materials and tools are not part of the delivery. Use the assembly materials and tools in compliance with the applicable occupational health and safety directives.

2.2 Device description

The setup of the device is carried out via the display and adjustment module. For further information refer to *Keypad functions* on page 41.

A piezoresistive sensor element is used in the measuring cell.

The measuring device is supplied ready for operation. The factory settings for the process data correspond to your order specifications.

2.2.1 Device design

The following drawings show the basic components of the differential pressure transmitter.

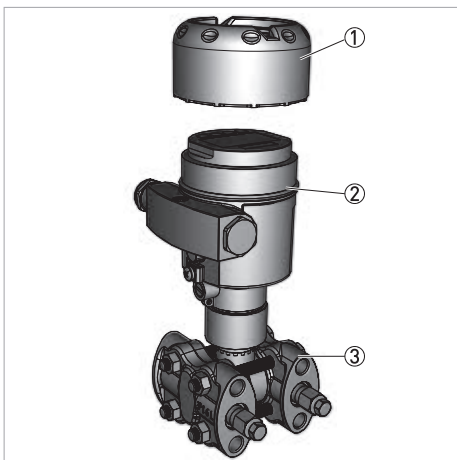

Figure 2-2: Basic components of single chamber pressure transmitter

- ① Housing cover, optional with display and adjustment module below
- ② Housing with electronics
- ③ Process assembly with measuring cell

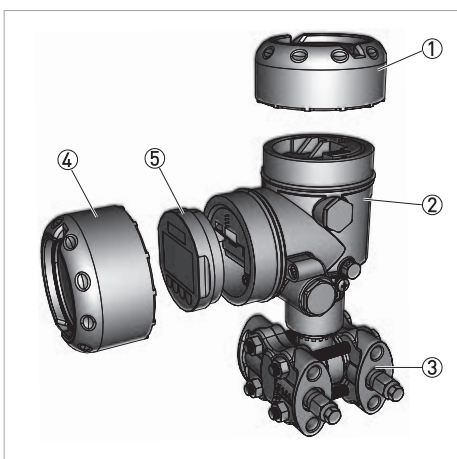

Figure 2-3: Basic components of double chamber differential pressure transmitter

- ① Housing cover
- ② Housing with electronics
- ③ Process assembly with measuring cell
- ④ Housing cover, optional with display and adjustment module below
- ⑤ Operating and display module

2.2.2 Connection variants

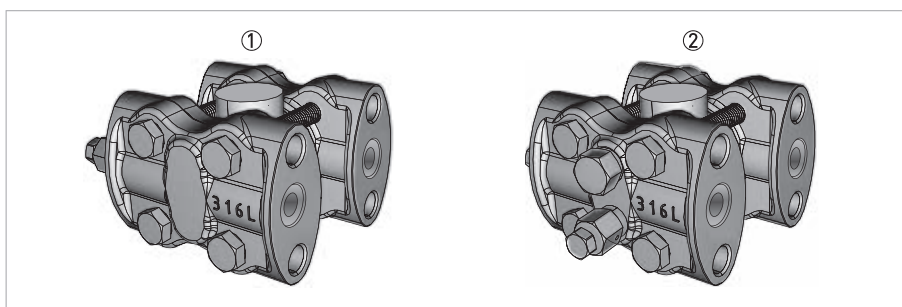

Figure 2-4: Process assembly

- ① Rear vent on process axis
- ② Side vent

Following connection variants are available:

- Process connection: 1/4-18 NPT (female) as well as IEC 61518 A
- Optional: Oval flange adapter 1/2-14 NPT (female)
- Mounting thread: 7/16 UNF, optional M10

The optional venting and drain valves on the device must be chosen according to the installation situation.

2.3 Nameplates



DANGER!

For devices used in hazardous areas, additional safety notes apply; please refer to the Ex documentation.



INFORMATION!

Look at the device nameplate to ensure that the device is delivered according to your order. Check for the correct supply voltage printed on the nameplate.

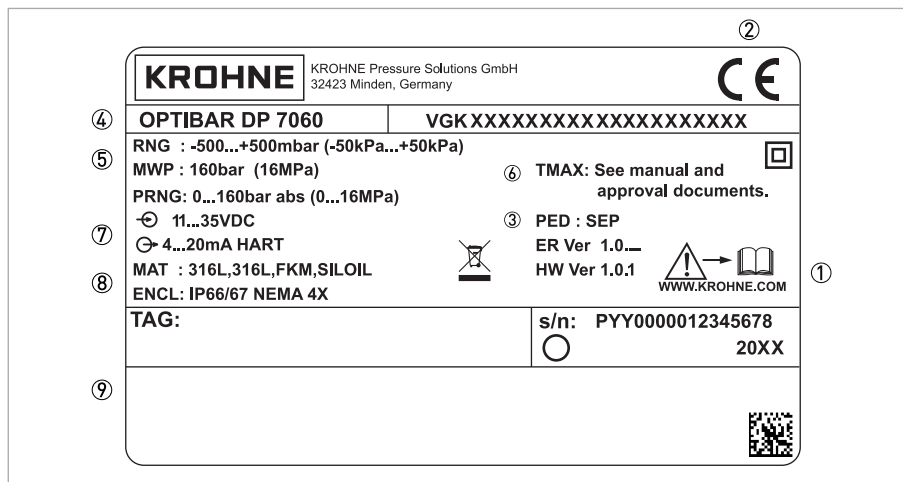

Figure 2-5: Example for a nameplate

- ① Observe the installation and operating instructions
- ② CE marking and marking of notified body
- ③ Hardware version
- ④ Product name and type code
- ⑤ Nominal range
Permissible process pressure
Nominal range of absolute pressure measurement
- ⑥ Permissible temperature range
- ⑦ Electronics power supply and signal output
- ⑧ Ingress protection and material of wetted parts
(Diaphragm, process connection, sealing and fill fluid)
- ⑨ Approvals and approval guidelines

2.4 Terms and abbreviations

The following terms and abbreviations are used in this document.

URL Upper Range Limit	Upper measuring range limit. Also called nominal range. The highest value that can be measured by a particular device.
LRL Lower Range Limit	Lower measuring range limit. The lowest value that can be measured by a particular device.
URV Upper Range Value	The calibrated measuring range or the highest adjusted measured value. This value corresponds to the 20 mA signal.
LRV Lower Range Value	The calibrated measuring range or the lowest adjusted measured value. This value corresponds to the 4 mA signal.
SPAN Span	Measuring span or measuring range. $SPAN = URL - LRL$
CAL SPAN Calibrated Span	Calibrated or adjusted measuring span. $CAL SPAN = URV - LRV$. Also called "cSPAN". This is the span set to the 4...20 mA output.
TD Turn Down	The ratio from the measuring span to the adjusted measuring span. $TD = SPAN / (CAL SPAN) = (+URL) / (CAL SPAN)$ The following applies: $URV \leq URL$, $CAL SPAN \leq SPAN$, $TD \geq 1$

Example for TD Turn Down	
LRL = 0 bar URL = 3 bar / 43.5 psi	SPAN = 3 bar / 43.5 psi
URV = 2 bar / 29 psi LRV = 0.5 bar / 7.25 psi	CAL SPAN = 1.5 bar / 21.75 psi TD = 2:1

3.1 General notes on installation

**INFORMATION!**

Inspect the packaging carefully for damages or signs of rough handling. Report damage to the carrier and to the local office of the manufacturer.

**INFORMATION!**

Do a check of the packing list to make sure that you have all the elements given in the order.

**INFORMATION!**

Look at the device nameplate to ensure that the device is delivered according to your order. Check for the correct supply voltage printed on the nameplate.

3.2 Ingress protection for housing

The housing of the signal converter fulfills the requirements for ingress protection in accordance with IEC 60529. Housing for protection category IP69K in accordance with ISO 20653 is also available. For further information refer to *Technical data* on page 67.

**CAUTION!**

The first digit stands for the protection of the inner electronic components against the ingress of foreign bodies including dust. The first digit "6" means that the housing is dust-proof. The second digit designates the protection of the inner electronic components against the ingress of water. The second digit "6" means that the housing is waterproof and also resistant against a strong jet of water. The number "7" means that the housing is waterproof even submersed under water for a given pressure and time. The number "8" means that the housing is permanently waterproof even under water.

3.3 Packaging

**CAUTION!**

Devices for oxygen applications are sealed in PE foil and a "DEGREASED" label (oil and grease-free) is affixed. Remove this foil just before mounting the device. Once the protection for the process connection has been removed, the label O₂ will be visible on the process connection. No oil, grease or dirt should penetrate. Danger of explosion.

Your device was protected by packaging during transport. Its capacity to handle normal loads during transport is assured by a test following ISO 22248. The packaging of standard devices consists of environmentally friendly, recyclable cardboard and PE foil. For special versions, PE foam or PE foil is also used. Dispose of the packaging material via specialised recycling companies.

3.4 Storage

**CAUTION!**

Observe the storage information found on the packaging. Labels on the original packaging must always remain legible and may not be damaged.

- Store the device in a dry, dust-free location.
- Avoid extended direct exposure to the sun.
- Store the device in the original packaging supplied.
- Do not expose to aggressive media.
- Avoid mechanical shocks.
- Storage temperature: -40...+80°C / -40...+176°F
- Relative air humidity: 20...85%.

3.5 Transport

- Use original packaging for transport and ensure that the packaging does not get crushed or damaged by sharp objects or other boxes.
- Do not throw or drop the device.
- Avoid temperatures below -40°C / -40°F and above +80°C / +176°F.
- When transporting by ship, use seaworthy outer packing.

3.6 Installation specifications

**INFORMATION!**

Observe the relevant directives, ordinances, standards and accident prevention regulations (e.g. VDE/VDI 3512, DIN 19210, VBG, Elex V, etc.).

The accuracy of the measurement is only guaranteed if the transmitter and accompanying impulse line(s), if any, have been correctly installed. In addition, extreme ambient conditions including large fluctuations in temperature, vibrations and shocks should be kept as far away as possible from the measuring equipment.

3.7 Mounting



CAUTION!

- *Prior to installing the transmitter, it is essential to verify whether the version of the device on hand completely fulfils the technical and safety requirements of the measuring point. This applies in particular to the measuring range, overpressure resistance, temperature, explosion protection and operating voltage.*
- *Check the materials used for the wetted parts (e.g. gasket, process connection, separating diaphragm etc.) for suitability as regards process compatibility.*
- *The device must not be heated by radiated heat (e.g. exposure to the sun) to an electronics housing surface temperature above the maximum permissible ambient temperature. If it is necessary to prevent damage from heat sources, a heat protection (e.g. sun shade) has to be installed.*

3.7.1 Rotating the housing

The transmitter housing can be rotated 350° for better readability of the display or access to the wiring. A stop prevents the housing from being rotated too far.



- On all dual chamber housings, the locking screw must be loosened at the neck of the housing.
-  The housing can then be rotated to the desired position.
- Once the desired position is reached, tightened the locking screw.

3.7.2 Mounting the display and adjustment module

The optional display and adjustment module can be set in any one of four different positions at 90° intervals. The installation of the adjustment module is carried out as per the illustrations below. To do so, unscrew the housing cover and insert the adjustment module clockwise. The display can be installed rotated at 90°. It is not necessary to interrupt the power supply.

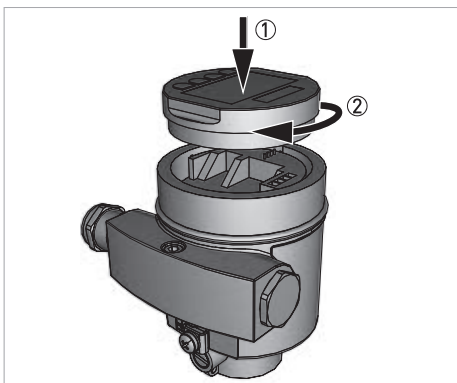

Figure 3-1: Installation in single chamber housing

- ① Insert the display and adjustment module into the housing
- ② Turn the display and adjustment module clockwise

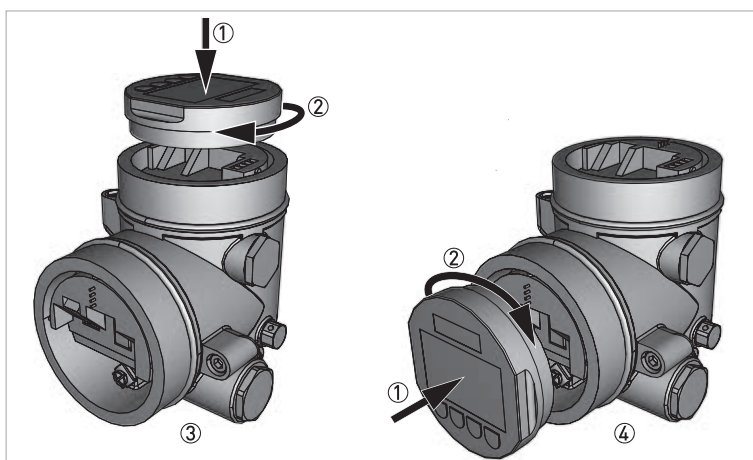

Figure 3-2: Installation in double chamber housing

- ① Insert the display and adjustment module into the housing
- ② Turn the display and adjustment module clockwise
- ③ Mounting on top
- ④ Mounting at side

3.7.3 Process connections

Before installation of the device, please check the correct position of the high (H) and low (L) pressure side. You can see the designations (H / L) underneath the measuring cell acc. to the following figure.

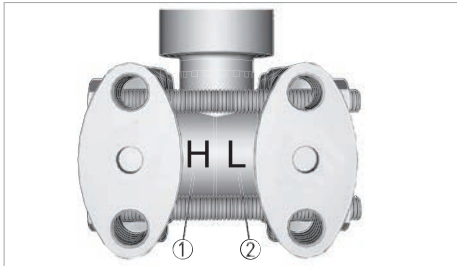

Figure 3-3: Process connection of the differential pressure transmitter

- ① High-pressure side
- ② Low-pressure side

The process connections of the differential pressure transmitter are usually 1/4-18 NPT (female) at a distance of 54 mm / 2.13". Through optional oval flange adapters, the connections 1/2-14 NPT (female) are also selectable.

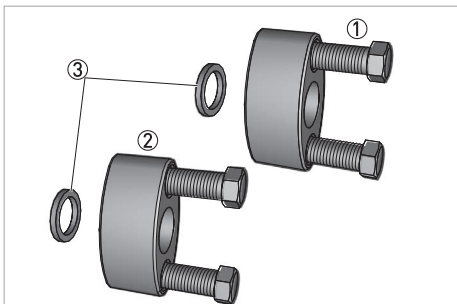

Figure 3-4: Oval flange adapter

- ① 7/16 UNF screws
- ② Oval flange adapter
- ③ Sealing ring



If the adapter is not supplied pre-assembled, proceed as follows:

- Position the adapter with inserted O-ring.
- Use the screws supplied to screw the adapter to the transmitter.
- Tighten the screws to a torque of 25 Nm (stainless steel screws) or 12.5 Nm (stainless steel acc. to NACE).

3.7.4 Mounting bracket

Scope of delivery

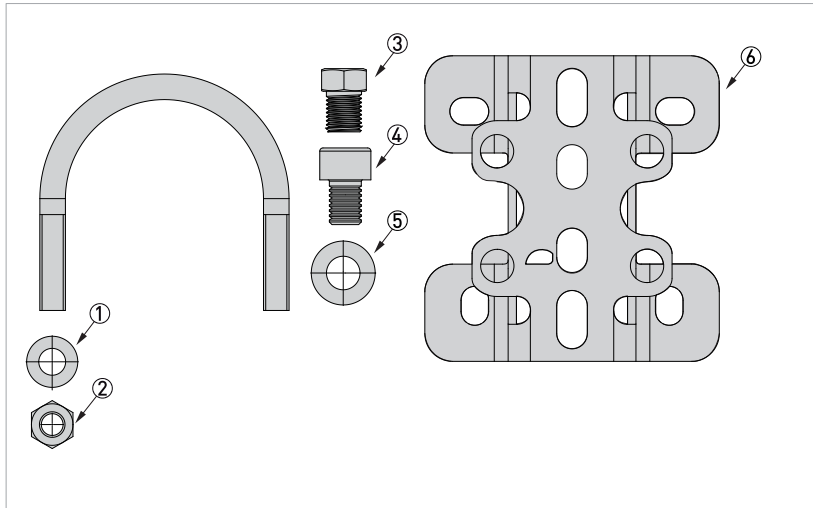

Figure 3-5: Scope of delivery

- ① 2x Washer M8
- ② 2x Hexagonal nut M8
- ③ 4x Hexagonal head screw 7/16-20 UNF
- ④ 2x Cylinder head screw M10
- ⑤ 2x Washer M10
- ⑥ 1x Mounting bracket

Mounting bracket for easy pipe or wall mounting.

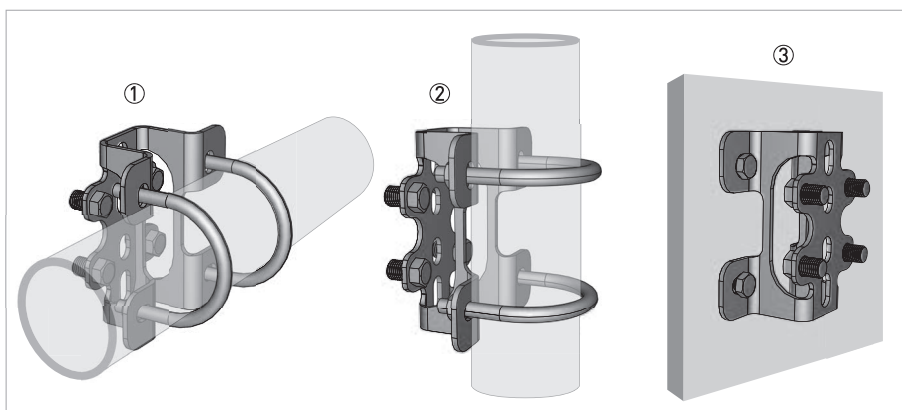

Figure 3-6: Mounting bracket

- ① Horizontal 2" pipe mounting
- ② Vertical 2" pipe mounting
- ③ Wall mount

Mounting bracket for easy valve and pressure transmitter mounting.

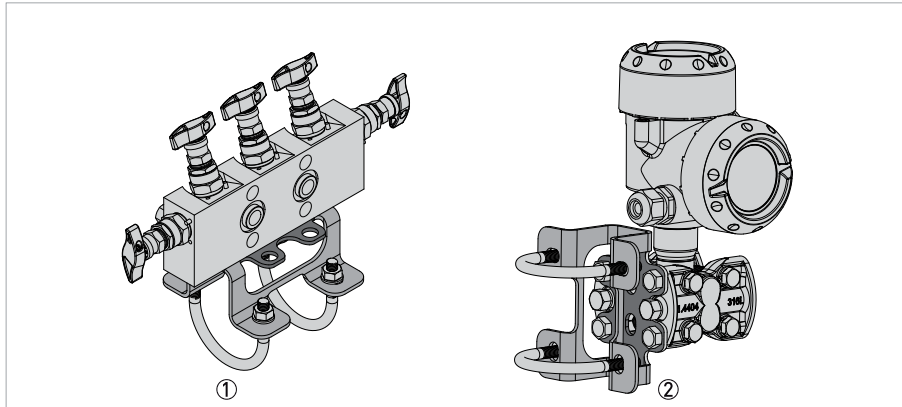

Figure 3-7: Mounting bracket

- ① Mounting bracket on a valve
- ② Mounting bracket on a pressure transmitter

3.7.5 Manifolds

Manifolds allow for easy installation and commissioning of the transmitter. They separate the device from the process side and ensure simple control of the measuring point. They are available as 3-way and 5-way versions. The integrated equalize valve allows pressure equalization between the high (H) and low (L) pressure side during commissioning. With the manifold, it is possible to disassemble the differential pressure transmitter without interrupting the process. This means higher system availability and even simpler commissioning or maintenance purposes. The 3-way manifold with double-sided flange adapters allows a mechanically robust connection between the differential pressure transmitter and, for example, the impulse lines or the flange adapters of an averaging pitot tube. With a 5-way manifold, two additional valves allow to blow out of the impulse lines and the calibration of the differential pressure transmitter in place.

3.7.6 Differential pressure transmitter

Primary elements, such as averaging pitot tubes, orifice plates or venturis are designed for certain line sizes and flow conditions. Therefore, prior to installation, the line size and pressure rating has to be checked and the measuring point number compared. For detailed instructions on installing a primary element refer to DIN EN ISO 5167.

3.7.7 Pressure connection with impulse line

Please review the following information for pressure connection with impulse line:

- Select the shortest impulse line possible and install without sharp bends.
- Avoid material deposits and blockages in the impulse line. Accordingly, install the impulse lines so that such occurrences are impossible. The slope should not fall below approx. 8% in the piping.
- Ensure that the impulse line flows freely before installation and rinse with compressed air or, even better, with the product itself.
- When measuring liquid, the impulse line must be completely purged of air.

- Run the impulse line so that trapped air (when measuring liquids) or condensate (when measuring gas) can flow back into the process.
- Hot steam must not enter the process connection (the over temperature will destroy the device). To avoid this situation, a suitable water trap (such as a syphon filled with water prior to installation) can be installed upstream from the measuring device.
- All connections must be tight and fixed properly.
- The process lines must be installed so that the medium cannot be blown out of the measuring chambers.

3.7.8 Vibrations

In case of strong vibrations at the measuring point, the device should be mounted via impulse lines in a calm place.

3.7.9 Temperature limits

Higher process temperatures often mean also higher ambient temperatures for electronics and connection cables. Make sure that the upper temperature limits for the environment of the electronics housing and connection cable are not exceeded. For further information refer to *Technical data* on page 67.

3.8 Instructions for oxygen applications

Oxygen and other gases can be explosive when brought into contact with oils, grease and plastics, so the following measures must also be taken:

- All components of the plant, such as e.g. measuring devices must be cleaned according to the requirements of BAM (DIN 19247).
- Depending on the seal material, certain temperatures and pressures must not be exceeded in oxygen applications, refer to *Technical data* on page 67.



CAUTION!

Devices for oxygen applications are sealed in PE foil and a "DEGREASED" label (oil and grease-free) is affixed. Remove this foil just before mounting the device. Once the protection for the process connection has been removed, the label O₂ will be visible on the process connection. No oil, grease or dirt should penetrate. Danger of explosion.

3.9 Venting

The ventilation for the electronics housing is assured via a filter element in the vicinity of the cable glands, which is permeable to air but moisture-blocking.



CAUTION!

In order to ensure effective ventilation, the filter element must be always free of deposits.



CAUTION!

Do not use a high-pressure cleaner to clean the housing. The filter element may become damaged and as a result moisture can penetrate into the housing. The exception to this is the IP69K single chamber housing.

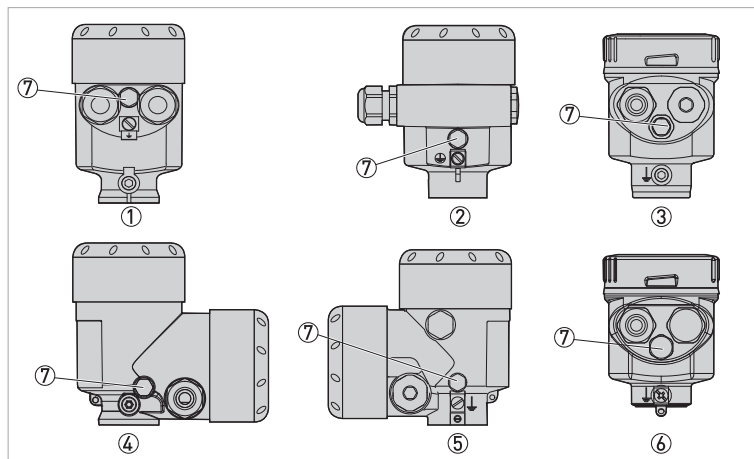

- ① Single chamber housing, plastic, stainless steel precision casting
- ② Single chamber housing, aluminium
- ③ Single chamber housing, stainless steel electro-polished
- ④ Double chamber housing, plastic
- ⑤ Double chamber housing, aluminium
- ⑥ Single chamber housing IP69k
- ⑦ Filter element

3.10 Measurement setup for flow measurement

3.10.1 In gases and liquids with solids content

- Include the pressure tapping points above or to the side on the process line.
- The device must be mounted above the chosen tapping point.

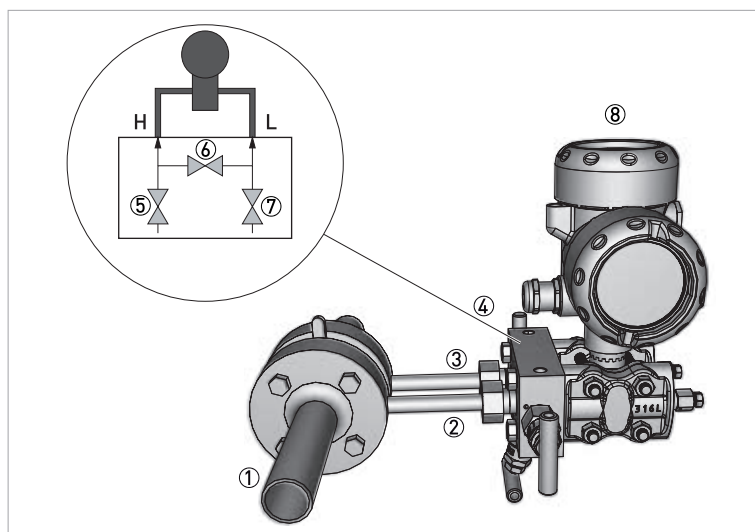

Figure 3-8: Application example

- ① Pipeline with primary element
- ② Low-pressure line (L)
- ③ High-pressure line (H)
- ④ 3-valve manifold
- ⑤ Shut-off valve
- ⑥ Equalizing valve
- ⑦ Shut-off valve
- ⑧ Pressure transmitter

3.10.2 In vapours and pure liquids

- Include the pressure tapping points to the side on the process line.
- The device must be mounted at the same height or underneath the tapping points.
- In steam applications, fill the impulse lines and and/or condensate vessels with an appropriate liquid.

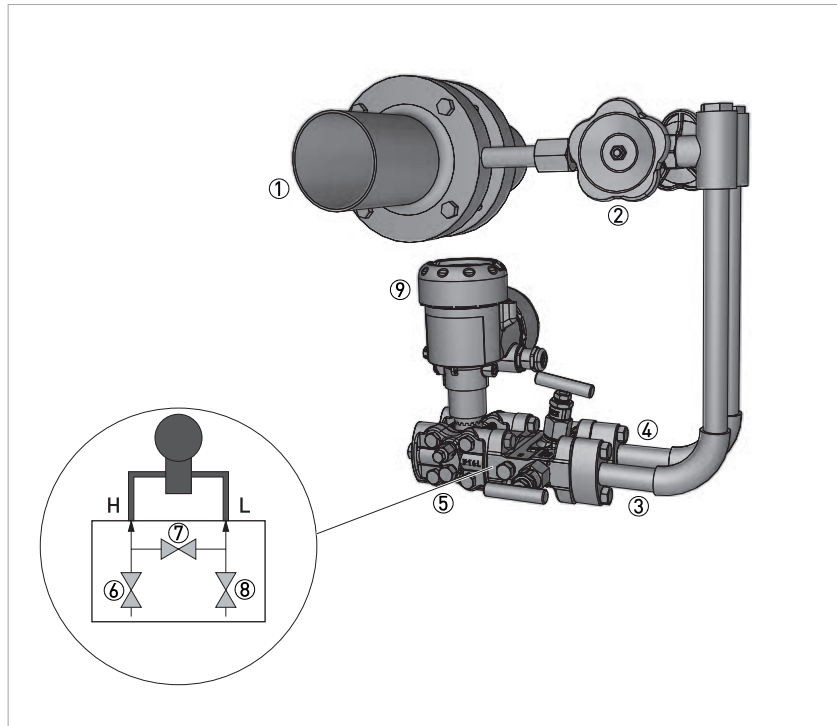

Figure 3-9: Application example

- ① Pipeline with primary element
- ② Primary shut-off valve
- ③ Low-pressure line (L)
- ④ High-pressure line (H)
- ⑤ 3-valve manifold
- ⑥ Shut-off valve
- ⑦ Equalizing valve
- ⑧ Shut-off valve
- ⑨ Pressure transmitter

3.11 Measurement setup for level measurement

3.11.1 In open vessels with impulse line

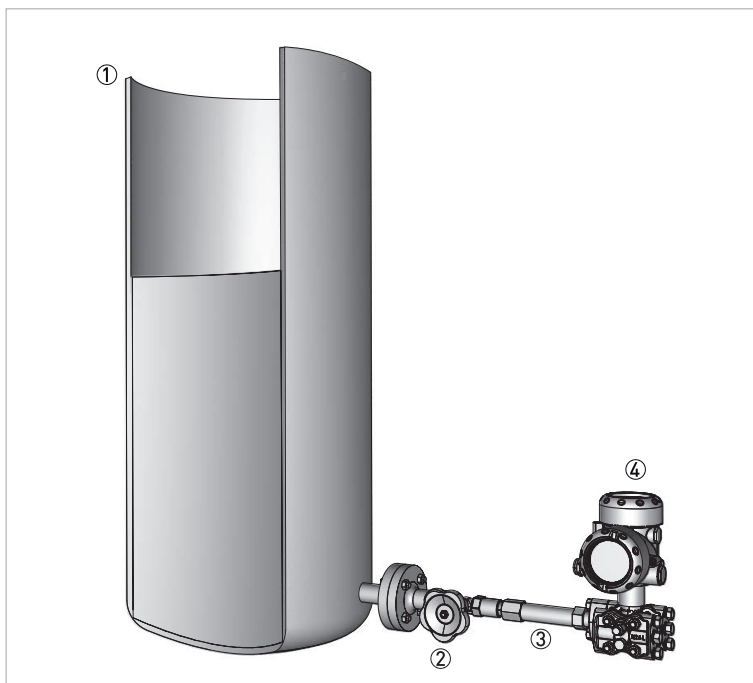

Figure 3-10: Application example

- ① Tank
- ② Shut-off valve
- ③ Impulse line
- ④ Differential pressure transmitter

The following points should be observed in this application:

- Mount the differential pressure transmitter below the lower process connection so that the impulse lines are always filled with liquid.
- The low-pressure side (L) is open to atmospheric pressure.
- For measurements of fluids with solid content, the installation of separators and drain valves is recommended to enable collection and removal of debris and sediment.

3.11.2 In closed vessels with gas-filled impulse lines

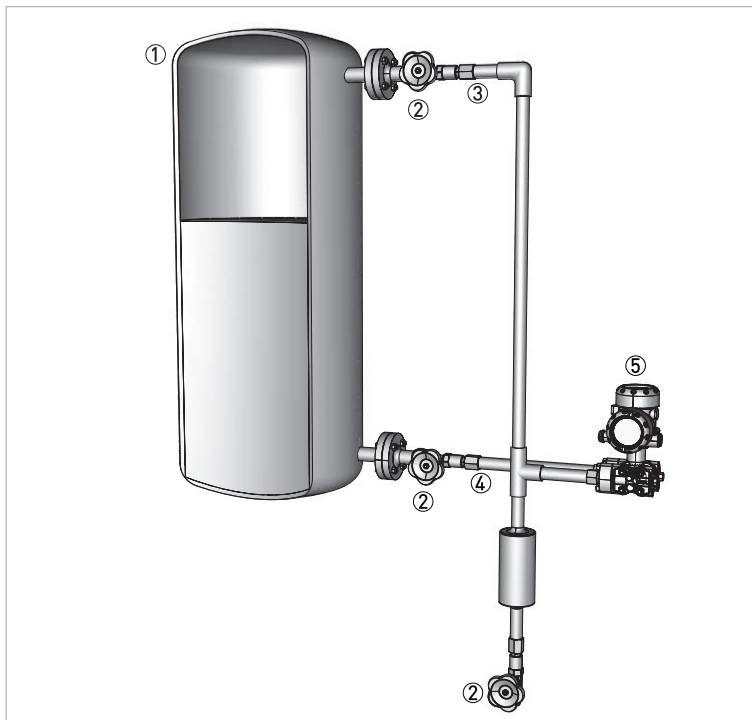

Figure 3-11: Application example

- ① Tank
- ② Shut-off valve
- ③ Low-pressure line (L)
- ④ High-pressure line (H)
- ⑤ Differential pressure transmitter

The following points should be observed in this application:

- Mount the differential pressure transmitter below the lower process connection so that the impulse line is always filled with liquid.
- The low-pressure side (L) must always be connected above the maximum level.
- For measurements of fluids with solid content, the installation of separators and drain valves is recommended to enable collection and removal of debris and sediment.

3.11.3 In closed vessels with liquid / condensate filled impulse lines



Figure 3-12: Application example

- ① Tank
- ② Shut-off valve
- ③ Low-pressure line (L)
- ④ High-pressure line (H)
- ⑤ Differential pressure transmitter

The following points should be observed in this application:

- Mount the differential pressure transmitter below the lower process connection so that the impulse lines are always filled with liquid.
- The low-pressure side (L) must always be connected above the maximum level.
- For measurements of fluids with solid content, the installation of separators and drain valves is recommended to enable collection and removal of debris and sediment.

4.1 Safety instructions

**DANGER!**

All work on the electrical connections may only be carried out with the power disconnected. Take note of the voltage data on the nameplate!

**DANGER!**

Observe the national regulations for electrical installations!

**WARNING!**

Observe without fail the local occupational health and safety regulations. Any work done on the electrical components of the measuring device may only be carried out by properly trained specialists.

**INFORMATION!**

Look at the device nameplate to ensure that the device is delivered according to your order. Check for the correct supply voltage printed on the nameplate.

4.2 Notes for electrical cables

**DANGER!**

The device must be grounded to a spot in accordance with regulations in order to protect personnel against electric shocks.

**DANGER!**

Cables may only be connected when the power is switched off! Since the transmitter has no switch-off elements, overcurrent protection devices, lightning protection and/or energy isolating devices need to be provided by the customer.

Metric thread M16 x 1.5 mm

The cable glands with metric threads are screwed in by the factory. They are sealed using plastic plugs to protect them during transport. Remove these plugs prior to establishing an electrical connection.

4.2.1 Requirements for signal cables supplied by the customer

If the signal cable was not ordered, it is to be provided by the customer. The following requirements regarding the electrical specifications of the signal cable must be observed:

Specifications for standard signal cables

- Test voltage: ≥ 500 VAC RMS (750 VDC)
- Temperature range: $-40\dots+105^{\circ}\text{C}$ / $-40\dots+221^{\circ}\text{F}$
- Capacity: ≤ 200 pF/m / 61 pF/ft
- Inductance: ≤ 0.7 $\mu\text{H}/\text{m}$ / 0.2 $\mu\text{H}/\text{ft}$
- Use cable with round cross section.
- We generally recommend the use of a shielded cable for HART[®] multidrop mode.

Make sure that the cable used features the required temperature resistance and fire safety for the maximum possible ambient temperature.

4.2.2 Laying electrical cables correctly

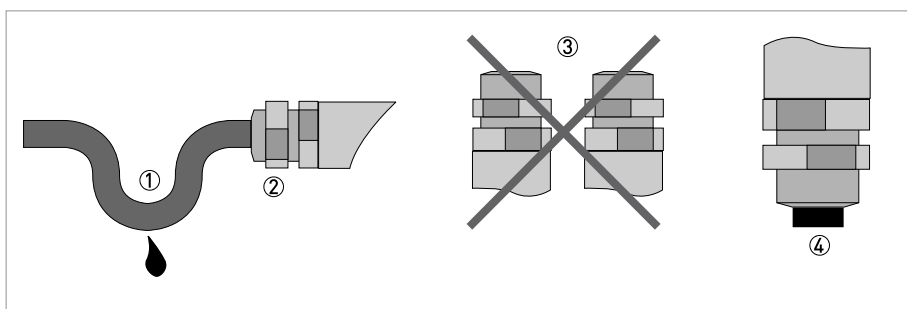

Figure 4-1: Protect housing from dust and water



- ① Lay the cable in a loop just before the housing.
- ② Tighten the screw connections of the cable entry.
- ③ Never mount the housing with the cable entries facing upwards.
- ④ Seal cable entries that are not needed with a plug.

4.2.3 Cable preparation

The device is connected with standard two-wire cable without shielding. If electromagnetic interference is expected which is above the test values of EN 61326-1 for industrial areas, a shielded cable should be used.

Check which outer diameter is suitable for the cable gland in order to ensure the sealing effect according to the specified IP protection class.

- 4.5...10 mm / 0.18...0.39" (standard)
- 4...11 mm / 0.16...0.43" (optional)

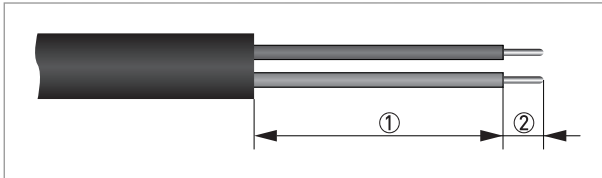

Figure 4-2: Stripping the cable

- ① 40...50 mm / 1.6...2"
- ② 5 mm / 0.2"

4.2.4 Cable entry 1/2-14 NPT (female)

With plastic housings, the NPT cable gland or the conduit steel tube must be screwed without grease into the thread.

4.2.5 Connector pin assignment

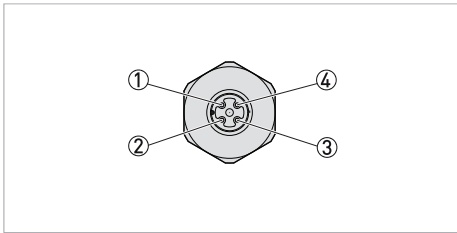

Figure 4-3: Connector M12 x 1, 4-pin, A-coding

- ① Shield
- ② Not used
- ③ VS-
- ④ VS+

Contact pin	Colour of cable	Electronic insert for terminal
Pin ①	Brown	1
Pin ④	Blue	2

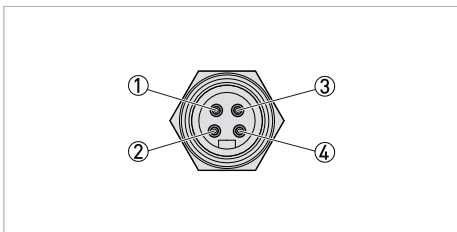

Figure 4-4: 7/8 connector, Foundation Fieldbus (FF)

- ① VS-
- ② VS+
- ③ Not connected
- ④ Cable shield

Contact pin	Colour of cable	Electronic insert for terminal
Pin ①	Blue	1
Pin ②	Brown	2
Pin ④	Green / yellow	Grounding

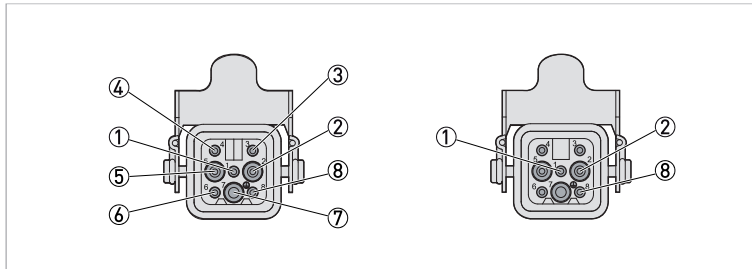

Figure 4-5: Connector, Harting HAN 8D (left) and Harting HAN 7D (right)

- ① VS-
- ② VS+

Contact pin	Colour of cable	Electronic insert for terminal
Pin ①	Black	1
Pin ②	Blue	2
Pin ⑧	Green / yellow	Grounding

4.2.6 Connection to the power supply

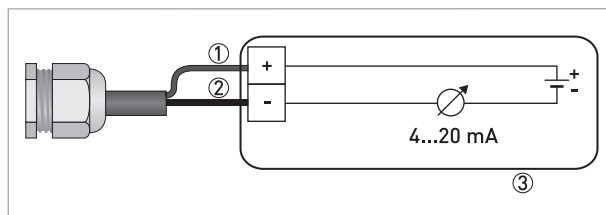

Figure 4-6: Connection to the power supply

- ① Red
- ② Black
- ③ Power supply with load

4.2.7 Cable shield and grounding

If a shielded cable is necessary, connect the cable shield on both ends to the grounding potential.

In the device, the cable shield must be connected directly to the internal ground terminal.

The ground terminal outside on the housing must be connected to the grounding potential with low impedance.



DANGER!

In hazardous areas, the grounding is carried out according to the installation instructions.



CAUTION!

Significant potential differences exist inside galvanization plants as well as on vessels with cathodic corrosion protection. A two-sided shield grounding can cause unacceptably high shield currents as a result.



CAUTION!

The metallic and wetted parts (process connection, cap flange, measuring cell and separating diaphragm etc.) are conductive connected with the inner and outer ground terminal on the housing.

4.3 Electrical connection

The power supply and signal output are connected via screw terminals in the housing. The display and adjustment module is connected to the interface adapter via contact pins.

4.3.1 Connection in the terminal compartment

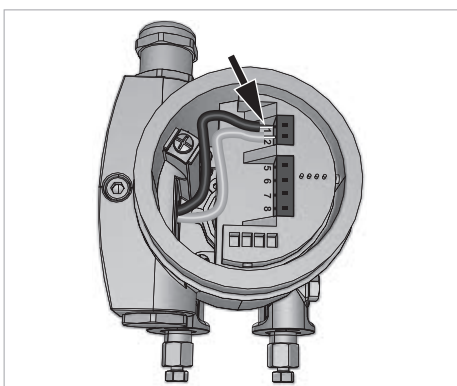

Figure 4-7: Terminal compartment from above



Procedure

- Unscrew the housing cover.
- If present, remove the display and adjustment module by turning it to the left.
- Loosen union nut of the cable gland.
- For preparation of connection cable refer to *Cable preparation* on page 33.
- Push the cable through the cable gland into the terminal compartment.

- Insert the wire ends into the open terminal connection according to the wiring plan. Flexible cores with wire end sleeves as well as solid cores can be inserted directly into the terminal openings. In case of flexible cores, press the spring terminal with a small screwdriver to open the terminal opening.
- Check the proper hold of the wires in the terminals by lightly pulling on them.
- Connect the cable shield to the internal ground terminal, connect the outer ground terminal to the customer/plant equipotential bonding.
- Tighten the union nut of the cable gland. The sealing ring must completely enclose the cable.
- Screw the housing cover back on.

4.3.2 Single chamber housing



DANGER!

For devices used in hazardous areas, additional safety notes apply; please refer to the Ex documentation.

The following illustration applies to both the non-Ex as well as the Ex ia, and the Ex d version.

Electronics compartment

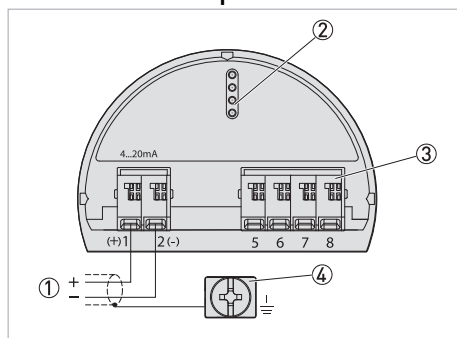

- ① Power supply / signal output
- ② Interface adapter for the display and adjustment module
- ③ Digital interface
- ④ Ground terminal for connection of the cable shield

4.3.3 Double chamber housing

**DANGER!**

For devices used in hazardous areas, additional safety notes apply; please refer to the Ex documentation.

The following illustration applies to both the non-Ex as well as the Ex ia, and the Ex d version.

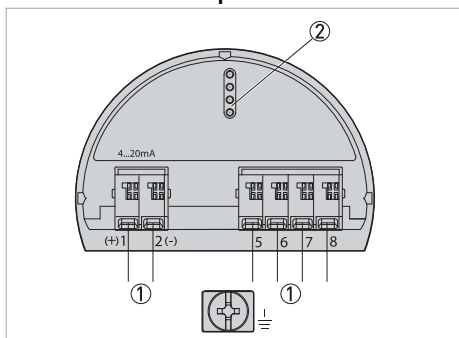
Electronics compartment

- ① Internal connection to terminal compartment
- ② Interface adapter for the display and adjustment module

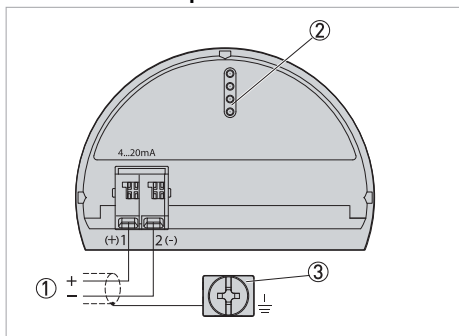
Terminal compartment: Standard

- ① Power supply / signal output
- ② Interface adapter for the display and adjustment module
- ③ Ground terminal for connection of the cable shield

Terminal compartment: Additional current output

To make a second measured value available for use, you can use the supplementary electronics "Additional current output". Both current outputs are passive and need a power supply.

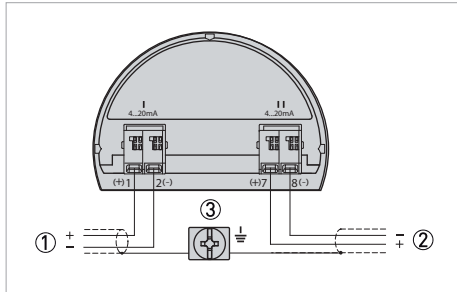

Figure 4-8: Additional current output

- ① First current output (I) - Voltage supply and signal output, sensor (HART®)
- ② Additional current output (II) - Voltage supply and signal output (without HART®)
- ③ Ground terminal for connection of the cable screening

4.4 Grounding the measuring device



WARNING!

Within galvanic plants as well as vessels with cathodic corrosion protection there are considerable potential differences. Considerably equipotential bonding currents can be caused via the cable shield when the shield is grounded on both ends. To avoid this, the cable shield must only be connected to the grounding potential on one side of the control cabinet in such applications. The cable shield must not be connected to the internal ground terminal in the device and the outer ground terminal on the housing not to the equipotential bonding!



CAUTION!

The metallic and wetted parts (process connection, cap flange, measuring cell and separating diaphragm etc.) are conductive connected with the inner and outer ground terminal on the housing.

If a shielded cable is necessary, connect the cable shield on both ends to the grounding potential. In the signal converter, the cable shield must be connected directly to the internal ground terminal. The ground terminal outside on the housing must be connected to the equipotential bonding with low impedance. If equipotential bonding currents are expected, the evaluation side must be connected with a ceramic capacitor (e.g. 1 nF, 1500 V). The low frequency equipotential bonding currents are thus suppressed, but the protective effect against high frequency interference signals remains.

4.5 Description of the current output

The current output is a 2-wire 4...20 mA output with a low alarm of 3.6 mA and high alarm of 21 mA set by default. A high frequency HART® signal superimposes this signal. For further information on the current output, refer to *Technical data* on page 67.

5.1 Commissioning

The signal converter may only be started up after it has been completely installed and checked by appropriately qualified personnel. Switch on the operating voltage for start-up.

Prior to applying the operating voltage check that

1. the pressure transmitter is completely installed
2. the process connection fits properly
3. the signal and, if necessary, supply lines are properly connected
4. the impulse lines are completely filled with the process medium

After connecting the signal converter to the power supply or after voltage recovery, the device performs a self test for approximately 5 seconds.

Then proceed with start-up.

For more information refer to *Start-up* on page 46

5.2 Keypad functions



INFORMATION!

The device can be configured either via the relevant fieldbus or the adjustment module.

The display and adjustment module is used for indication of measuring values, adjustment and diagnosis.

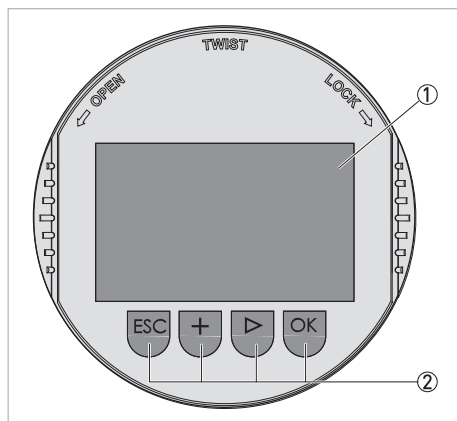

- ① LCD display
- ② Function buttons

The device is operated via the four keys of the display and adjustment module ②. The LC display ① indicates the individual menu items. Approx. 60 minutes after the last pressing of a key, an automatic reset in the indication of measuring values is triggered. Any values not confirmed with [OK] will not be saved.

[OK]

- Move back to the menu overview
- Confirm selected menu
- Editing the parameters
- Store value

[>]

- Change measured value
- Select list entry
- Select editing position

[+]

- Change value of the parameter

[ESC]

- Cancel entry
- Jump to next higher menu

5.3 Set up Bluetooth connection with smartphone/tablet

System requirements

Make sure that your smartphone/tablet meets the following system requirements

- Operating system: iOS 8 or higher
- Operating system: Android 5.1 or higher
- Bluetooth Smart 4.0 or higher

Download the OPTICHECK Pressure Mobile application from the "Apple App Store" or "Google Play Store" to your smartphone or tablet.

Activate Bluetooth



- Make sure that the Bluetooth function of the display and adjustment module is activated
- For this, the switch on the bottom side must be set to "On".

Note! Factory setting is "On".

Change sensor PIN

The security concept of Bluetooth operation requires that the default setting of the sensor PIN be changed. This prevents unauthorized access to the sensor. The default setting of the sensor PIN is "0000".



- Change the sensor PIN in the adjustment menu of the respective sensor, e.g. to "1111".

Bluetooth communication functions only if the actual sensor PIN differs from the default setting "0000". After the sensor PIN has been changed, sensor adjustment can be enabled again. For access (authentication) with Bluetooth, the PIN is still effective.

Connecting



- Start the adjustment app and select the function **Setup**. The smartphone/tablet searches automatically for Bluetooth-capable instruments in the area.
 - ➔ The message **Searching...** is displayed.
- All found instruments will be listed in the adjustment window. The search is continued automatically. Select the requested instrument in the device list.
 - ➔ The message **Connecting...** is displayed.

Authenticate

For the first connection, the operating device and the sensor must authenticate each other. After successful authentication, the next connection functions without authentication. For authentication, enter in the next menu window the 4-digit PIN which is used to lock/unlock the sensor (sensor PIN).

If an incorrect sensor PIN is entered, the PIN can only be entered again after a delay time. This time gets longer after each incorrect entry.

Connected

After connection, the sensor adjustment menu appears on the respective operating device. The display of the display and adjustment module shows the Bluetooth symbol and **connected**. Sensor adjustment via the keys of the display and adjustment module itself is not possible in this mode. If the Bluetooth connection is interrupted, e.g. due to a too large distance between the two devices, this is displayed on the operating device. The message disappears when the connection is restored.

Sensor parameter adjustment

The sensor adjustment menu is divided into **Setup** and **Diagnostics**. Enter the requested parameters and confirm via the keyboard or the editing field. The settings are then active in the instrument. Close the app to terminate the connection.

5.4 Quick set-up

To adapt the device quickly and easily to the application, select the menu item "Quick setup".

This essentially comprises:

- Application selection
- Sensor mounting correction
- Adjustment of the clamping range

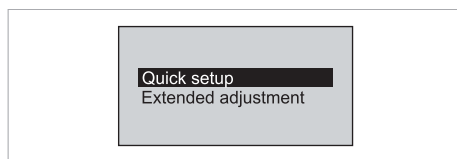
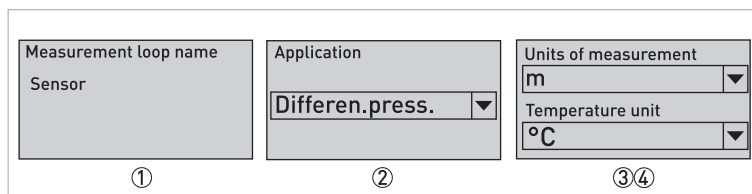

Figure 5-1: Quick set-up

In this chapter, not all settings are displayed graphically but all settings are described.



- ① **Measurement loop name**
Assign a suitable measurement loop name
- ② **Application**
The selection includes differential pressure, level, flow, interface and density measurement.
- ③ **Adjustment units**
Determine the temperature units of the device.
- ④ **Unit of static pressure**
Determine the unit of static pressure.

5.4.1 Adjustment differential pressure

Adjustment differential pressure

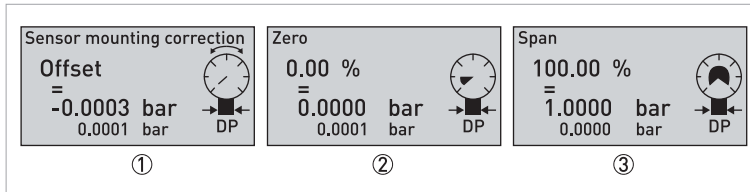

Figure 5-2: Adjustment differential pressure

① **Sensor mounting correction**

In this menu item you compensate the influence of the installation position of the device (offset) on the measured value.

② **Zero**

In this menu item you determine the zero point of your measurement (LRV)
This value corresponds to the output signal of 4 mA.

③ **Span**

This value corresponds 100%, or rather an output signal of 20 mA (URV)
If the zero point is actually 0, this value corresponds to the measuring span.

In bidirectional measurements the zero point has to be set in the negative measurement range.
e.g.

Zero 0%: -250 mbar

Span 100%: 250 mbar

Total span: 500 mbar

5.4.2 Adjustment level

Adjustment level

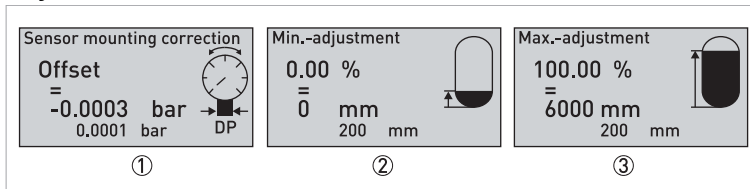

① **Sensor mounting correction**

In this menu item you compensate the influence of the installation position of the device (offset) on the measured value.

② **Min.-adjustment**

Enter the (pressure) value for the min. level.
At 0% this corresponds to the output signal of 4 mA.

③ **Max.-adjustment**

Enter the (pressure) value for the max. level.
At 100% this corresponds to the output signal of 20 mA.

5.4.3 Adjustment flow

Adjustment flow

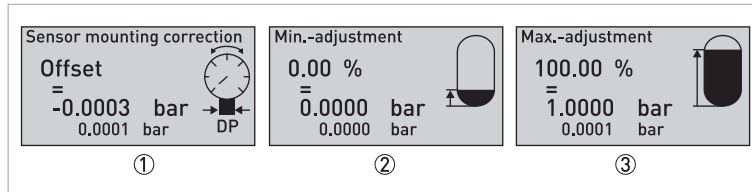

① **Sensor mounting correction**

In this menu item you compensate the influence of the installation position of the device (offset) on the measured value.

② **Min.-adjustment**

Enter the (pressure) value for the min. flow.

At 0% this corresponds to the output signal of 4 mA.

③ **Max.-adjustment**

Enter the (pressure) value for the max. flow.

At 100% this corresponds to the output signal of 20 mA.

④ **Linearization**

The following output characteristics are available for selection:

Linear (Standard)

To square root

Bi-directional linear

Bi-directional square root

User programmable

The adjustment "flow" is equal to the adjustment "differential pressure", with the additional setting for square root characteristics and low flow cut-off.

5.4.4 Adjustment density

Adjustment density

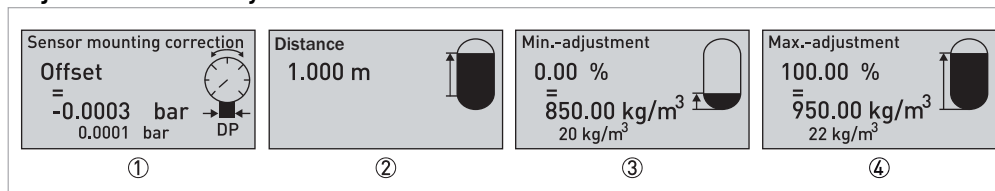

Figure 5-3: Adjustment density

① **Sensor mounting correction**

In this menu item you compensate the influence of the installation position of the device (offset) on the measured value.

② **Distance min. - max..**

Enter the distance between both measuring points.

③ **Min.-adjustment**

Enter the (pressure) value for the min. density.

This corresponds to the output signal of 4 mA.

④ **Max.-adjustment**

Enter the (pressure) value for the max. density.

At 100% this corresponds to the output signal of 20 mA.

5.5 Extended adjustment

The main menu is divided into five sections:

- Start-up
- Display
- Diagnosis
- Additional adjustments
- Info

5.5.1 Start-up

Measurement loop name	Assign a unique device ID. This is useful or even necessary in digital systems and for monitoring large systems.	
Application	In this menu item you select the application: differential pressure, level, flow, density and interface are available. The default setting is differential pressure.	
Units	In this menu item the adjustment units, as well as the temperature unit are determined. The selection of the adjustment unit determines the unit displayed in the "Min-adjustment" and "Max-adjustment" items. In "Level" mode, it is possible to carry out the adjustment in a height unit (e.g. meters). To do so, the density of the medium must also be specified.	
	Adjustment units	Differential pressure and flow mbar, bar, Pa, kPa, MPa, psi, mmH2O, mmHg, inH2O, inHg and User-defined
		Level Density input required: mm, cm, m, in and ft
		Density measurement kg/dm ³ and lb/ft ³
		Interface mm, cm, m, in and ft with density input/unit of media
Temperature unit	°C, °F and K	
Static pressure	mbar, bar, Pa, kPa, MPa, psi, mmH2O, mmHg, inH2O and inHg	

Sensor mounting correction	The mounting position of the device has a great impact on the measured value (offset), especially with small measuring ranges and isolating systems. The sensor mounting correction compensates this offset. The sensor mounting correction can automatically take on the current measured value as correction value (auto correct). Alternatively, this correction value can also be manually entered using the "Edit" function. Once the sensor mounting correction has taken place, the measured value is corrected to 0. The sensor mounting correction can compensate a maximum of 20% of the nominal range.	
	Offset	Input in adjustment unit, automatic transfer of the current measured value
Adjustment	Adjustment refers to setting the zero point (zero) and maximum measured value (span). These values correspond to the values of 4 and 20 mA. If the adjustment ranges are exceeded, the message "Outside parameter limits" is displayed.	
	Distance	Density Distance in m (for kg/cm ³) and ft (for lb/ft ³) Interface Distance in mm, cm, m, in and ft
	Min.-adjustment / Zero	Process pressure, differential pressure Zero in %, pressure Level and flow (standard 0%) Min. in X %, pressure or filling height Density Min. in X %, density Interface Min. in X %, interface
	Max.-adjustment / Span	Process pressure, differential pressure Span in %, pressure Level and flow (standard 100%) Min. in X %, pressure or filling height Density Min. in X %, density Interface Min. in X %, interface
Damping	For the damping of process-dependent measured value fluctuations, you can choose a suitable integration time. The values which can be entered are from 0 ... 999 seconds with an increment of 0.1 seconds.	
	Integration time	In 0.1 second increments
Linearisation	A linearisation is necessary for all vessels in which the volume does not increase linearly with the level height, e.g. in a horizontal cylindrical or spherical tank, and the indication or output of the volume is required. Corresponding linearisation curves are preprogrammed for these vessels. They represent the correlation between the level percentage and vessel volume. By activating the appropriate curve, the volume percentage of the vessel is displayed correctly. If a linearisation curve is selected, the measuring signal is no longer linearly proportional to the level. This must be taken into consideration by the user, particularly when setting the switching point on the limit switch.	
	Type of linearization	Level Linear, Horiz.cylinder, Sphere and User programmable
	The square of the flow is proportional to the pressure differential at the orifice plate or averaging pitot tube: $q^2 \sim dp$ To establish a linear relationship between flow rate and output variable, a square root extraction is required: $q \sim \sqrt{dp}$ The differential pressure transmitter has this square root function. It is selected in menu item "linearization curve". Enter the desired parameter using the appropriate keys and save your entries. When selecting the "bi-directional square root" flow, the minimum adjustment must be entered with a negative sign.	
	Type of linearisation	Flow Linear, To square root, Bi-directional linear, Bi-directional square root and User programmable

Current Output	In the current output menu, the saturation region for above or below a threshold is set. Under "Current output min./max." these limit values can be set. The factory setting is 3.8 mA and 20.5 mA. This corresponds to the NAMUR recommendation NE 43.		
	Mode	Output characteristic	0...100% = 4...20 mA or 0...100% = 20...4 mA Additional bi-directional flow: 20...4...20 mA or 4...20...4 mA
		Failure mode	≤ 3.6 mA, ≥ 21 mA, last valid measured value
	Min. and Max.	Min. current	3.8 mA, 4 mA
Maximum current		20.5 mA, 20 mA	
Lock adjustment / Unlock adjustment	In this menu item, a 4-digit PIN can be activated, which protects against undesirable or unintended changes of the settings. With a PIN active, remote access via software or other systems is also no longer possible.		
	Run now		

5.5.2 Display

Menu language	In this menu item you can set the desired language. Factory settings: English	
	German, English, French, Spanish, Portuguese, Italian, Dutch, Russian, Turkish, Polish, Czech, Japanese and Chinese	
Displayed value 1 and 2	In this menu item you can define how the measured value should be presented on the display. The factory setting is "Linear percent".	
	"Level"	Filling height or Pressure (Adjustment units), Static pressure, Percent, Scaled, Current output, Linear percent, Meas. cell temp. and Electronics temperature
	"Differential pressure"	Differential pressure, Static pressure, Percent, Scaled, Current output, Linear percent, Meas. cell temp. and Electronics temperature
	"Flow"	Flow, Differential pressure, Static pressure, Pressure/percent, Scaled, Current output, Linear percent, Totalizer 1, Totalizer 2, Meas. cell temp. and Electronics temperature
	"Interface"	Interface height, Differential pressure, Percent, Scaled, Current output, Linear percent, Meas. cell temp. and Electronics temperature
	"Density"	Density, Differential pressure, Percent, Scaled, Current output, Linear percent, Meas. cell temp. and Electronics temperature
Backlight	A backlight on the display is available, which can be turned on or off in this menu. By default, this function is disabled.	
	Off, On	

5.5.3 Diagnosis

Device status	Status signals	Check function, Out of Specification, Maintenance required, Failure
Peak value	The respective minimum and maximum pressure values are stored in the device. Under "Peak values", these values can be viewed or reset. In addition to the pressure, the minimum and maximum values of the sensor cell and the electronics temperature is stored. These can be viewed or reset here.	
	Peak value "Pressure"	Reset peak value
	Peak value "Differential pressure"	Reset peak value
	Peak value "Static pressure"	Reset peak value
	Peak value "Meas. cell temp."	Reset peak value
	Peak value "Electronics temperature"	Reset peak value
Simulation	In menu item "Simulation", measured values can be simulated via the current output. These are issued as both analogue and digital (via HART [®]). The simulation is automatically cancelled 60 minutes after the last key stroke.	
	For applications "Differential pressure"	Differential pressure, Static pressure, Percent, Current output, Linear percent, Meas. cell temp. and Electronics temperature
	For applications "Flow"	Flow, Differential pressure, Static pressure, Pressure, Scaled, Current output, Linear percent, Meas. cell temp. and Electronics temperature
	For applications "Level"	Filling height or Pressure (Adjustment units), Static pressure, Percent, Current output, Linear percent, Meas. cell temp. and Electronics temperature
	For applications "Interface"	Interface height, Differential pressure, Percent, Current output, Linear percent, Meas. cell temp. and Electronics temperature
	For applications "Density"	Density, Differential pressure, Percent, Current output, Linear percent, Meas. cell temp. and Electronics temperature

5.5.4 Additional adjustments

PIN	In this menu item the PIN can be changed. This option is only available if it has been enabled under "Setup - Lock adjustment". The PIN is "0000" by default factory conditions.	
	0000	Change PIN
Date / Time	Internal clock setting	
	Write date, time, data in device	
Reset	For further information refer to <i>Reset</i> on page 51.	
	Factory settings, Basic settings, Totalizer 1 and Totalizer 2	
Copy instrument settings	For further information refer to <i>Saving the device settings</i> on page 52.	
	Copy instrument settings	
Special parameters	Changing these settings is possible only after consultation with a service employee.	
Scaling	In menu item "Scaling variable" you define the scaling variables and the scaling unit for the level mode. In menu item "Scaling format" you define the scaling format on the display and the scaling of the level measurement for 0% and 100%.	
	Scaling variable	Scaling variable
		Scaling unit
	Scaling format	Scaling format
		100% corresponds - user-defined value
0% corresponds - user-defined value		
Current Output	In this menu item it is determined which measured variable relates to which current output. Under "Current output - Adjustment", the current output can be assigned a corresponding measured value.	
	Current output variable	For applications "Level" Filling height or Pressure (Adjustment units), Static pressure, Percent, Scaled, Linear percent, Meas. cell temp. and Electronics temperature
		For applications "Differential pressure" Differential pressure, Static pressure, Percent, Linear percent, Meas. cell temp. and Electronics temperature
		For applications "Flow" Flow, Differential pressure, Static pressure, Pressure, Percent, Scaled, Linear percent, Meas. cell temp. and Electronics temperature
		For applications "Interface" Interface height, Differential pressure, Percent, Scaled, Linear percent, Meas. cell temp. and Electronics temperature
		For applications "Density" Density, Differential pressure, Percent, Scaled, Linear percent, Meas. cell temp. and Electronics temperature
	Current output adjustment	0% = 0% or 100% = 100%
HART®-Mode	The differential pressure transmitter offers the HART® modes "Analogue current output" and "Fix current (4 mA)". Under "Fix current (4 mA)", up to 64 sensors can be operated on a two-wire multidrop mode. Each device must be assigned a HART® address between 0 and 63. The analogue signal is fixed at 4 mA. Under "Analogue current output", however, a 4...20 mA signal can also be issued for the assigned HART® address in multidrop mode.	
	HART® address	0...63
	Output mode	Analogue current output with HART® or Fix current (4 mA) with HART®

Primary element parameters	In this menu item more information can be given on the primary elements used in the "flow" application. This can be displayed as either flow or mass flow. The respective display and adjustment units can then be selected accordingly.	
	Unit	Volume flow, Mass flow and User-defined
	Adjustment	0% = xxxx m ³ /h, 100% = xxxx m ³ /h

5.5.5 Info

Device name	Device name
	Serial number
Instrument version	Software version
	Hardware version
Factory calibration	Factory calibration date
	Date of last change
Sensor characteristics	Order-related device characteristics

5.6 Reset

The reset function resets specific user entries. There are 2 reset functions available.

5.6.1 Delivery status

Restore the default values at the time of delivery, including the order-specific settings. A false signal suppression, user programmable linearization curve as well as the measured value memory will be deleted.

5.6.2 Basic settings

Reset the set data, including special parameters to the default values of the manufacturer. A false signal suppression, user programmable linearization curve as well as the measured value memory will be deleted.

The following menu items are affected during a reset

Menu item	Parameter	Default
Measurement loop name		Sensor
Application	Application	Level
Unit SIL	Adjustment units	mbar (cell ≤ 500 mbar) bar (cell ≥ 1 bar)
	Temperature unit	°C
Sensor mounting correction SIL		0.00 bar
Adjustment SIL	Zero / Min.-adjustment	0.00 bar - 0.00%
	Span / Max.-adjustment	+URL in bar - 100%
Damping SIL	Integration time	0.0 seconds

Menu item	Parameter	Default
Current output SIL	Current output mode	Output characteristic 4...20 mA Failure mode ≤ 3.6 mA
	Current output variable	Linear percent - Level
	Current output adjustment	0...100% = 4...20 mA
	Current output min./max.	Min. 3.8 mA Max. 20.5 mA
Lock adjustment		Unlock
Language		English
Displayed value 1		Current output in %
Displayed value 2		Meas. cell temp. in °C
Backlight		Enabled
simulation		Differential pressure
PIN		0000
Scaling	Scaling variable	Volume in l
	Scaling format	0% = 0 L / 100% = 0 L
HART®-Mode		Address 0

5.7 Saving the device settings

We recommend noting the parameters and archiving them afterwards. They are thus available for multiple use or service purposes. If the signal converter is equipped with a display and adjustment module, the most important data can be read out of the sensor into the display and adjustment module. The data remain there permanently even if the sensor power supply fails. If it is necessary to exchange the signal converter, the display and adjustment module is inserted into the replacement device and the data are written into the signal converter under the menu item "Copy device data".

The following data and settings are saved in the adjustment module:

- All data from the "Set-up" and "Display" menus
- Sensor-specific units
- Temperature unit
- Linearisation
- User programmable linearisation curve

5.7.1 Copy device settings

This function allows you to upload the selected data to the display and adjustment module or download selected data to the signal converter. This function serves as a backup of the data, since it is retained even if the power fails.

The following settings are saved:

- all settings from the "Setup" and "Display" menus
- the menu items "Reset" and "Date/Time"
- Special parameters

5.8 Diagnosis memory

The device has several internal memories which are available for diagnosis purposes. The data remain even with voltage interruption.

Measured value memory

Up to 60,000 measured values can be stored in a ring memory. Each entry contains a time stamp as well as the respective measured value. Storable values are for example:

- Differential pressure
- Static pressure
- Level
- Flow rate
- Density
- Interface
- Percent value
- Linear percent
- Scaled values
- Meas. cell temp.
- Electronic temperature

With the default factory settings, the measured value memory is active and stores differential pressure, measurement reliability and electronics temperature every minute. The requested values and recording conditions are set via a PC with PACTware™/DTM or the control system with EDD.

Event memory

Up to 500 events are automatically stored with a time stamp in the event memory (non-deletable). Each entry contains date/time, event type, event description and value. Event types are for example:

- Modification of a parameter
- Switch on and shut off times
- Status message acc. to NE 107
- Error message acc. to NE 107

The data are read out via a PC with PACTware™/DTM or the control system with EDD.

5.9 Failures and diagnostics

The operator of the system is responsible for taking suitable measures to remove interferences. The differential pressure transmitter offers maximum reliability. Nevertheless, faults can occur during operation. The first measures are to evaluate the error messages, check the output signals as well as the verification of measurement errors.

Asset Management and diagnostics acc. to NE 107

The device features self-monitoring and diagnostics according to NE 107 and VDI/VDE 2650. In addition to the status messages in the following tables there are more detailed error messages available under the menu item "Diagnostics" via the display and adjustment module, PACTware™/DTM and EDD.

Status messages

The status messages are divided into the following categories in accordance with NE 107:

- **Failure**
Due to a malfunction in the device, a failure message is output. This status message is always active. It cannot be deactivated by the user.
- **Check function**
The device is in operation, the measured value is temporarily invalid. This status message is inactive by default. It can be activated by the user via PACTware/DTM or EDD.
- **Out of specification**
The measured value is unstable because the device specification is exceeded. This status message is inactive by default. It can be activated by the user via PACTware™/DTM or EDD.
- **Maintenance required**
Due to external influences, the device function is limited. The measurement is affected, but the measured value is still valid. Plan in maintenance for the device because a failure is expected in the near future. This status message is inactive by default. It can be activated by the user via PACTware™/DTM or EDD.

5.9.1 Advanced Error codes

Failure

Code Text message	Cause	Action or description	DevSpec State in CMD 48
F013 No measurement value available	No valid measured value available	Check the measuring cell or the overpressure or low pressure conditions.	Bit 0 of byte 0...5
F017 Adjustment span too small	Adjustment not within specification	Change adjustment according to the limit values	Bit 1 of byte 0...5
F025 Error in the linearisation table	Index markers are not continuously rising, for example illogical value pairs	check the linearization table, Delete table/Create new	Bit 2 of byte 0...5
F36 No operable sensor software	Failed or interrupted software update	Repeat software update Check electronics version Exchange the electronics or send device for repair	Bit 3 of byte 0...5
F40 Error in the electronics	Hardware defect	Exchange the electronics or send device for repair	Bit 4 of byte 0...5
F041 Error in the electronics	No connection to sensor electronics	Check connection to sensor electronics (with remote version)	Bit 5 of byte 0...5
F042 Communication error slave	No connection to the slave	Check the connection between the master and slave	
F080	General software error	Disconnect operating voltage briefly	Bit 6 of byte 0...5
F105 Measured value is determined.	Device is still in the energizing phase. The measured value has not yet been determined.	Wait until the energizing phase is complete.	Bit 7 of byte 0...5
F125 Impermissible electronics temperature	Temperature of the electronics in the non-specified section	Check ambient temperature Isolate electronics Use device with higher temperature range	
F260 Error in the calibration	Error in the calibration carried out in the factory Error in EEPROM	Exchange the electronics Send device for repair	Bit 10 of byte 0...5
F261 Error in the configuration	Error during setup Error when carrying out a reset	Repeat setup, Repeat reset	Bit 11 of byte 0...5
F264 Installation / start-up error	Inconsistent settings (e.g. distance, adjustment units in application of process pressure) for selected applications or invalid sensor configuration (e.g. application of electronic differential pressure with a connected differential pressure measuring cell)	Changing settings or changing connected sensor configuration or application	Bit 12 of byte 0...5
F265 Measurement function disturbed	Sensor no longer carries out a measurement	Carry out a reset Disconnect operating voltage briefly	Bit 13 of byte 0...5
F266 Impermissible operating voltage	Operating voltage is below the specified range	Check electrical connection - if necessary, increase operating voltage	

Check function

Code Text message	Cause	Action or description	DevSpec State in CMD 48
C700 Simulation Active	A simulation is active	Finish simulation Wait for automatic end after 60 minutes	"Simulation Active" in "Standardised Status 0"

Out of specification

Code Text message	Cause	Action or description	DevSpec State in CMD 48
S600 Impermissible electronics temperature	Temperature of the electronics in the non-specified section	Check ambient temperature Isolate electronics Use device with higher temperature range	Bit 23-0 of byte 14...24
S603 Impermissible operating voltage	Operating voltage below specified range	Check electrical connection - if necessary, increase operating voltage	Bit 23-1 of byte 14...24
S605 Pressure value out of specification	Measured process pressure below or above the setting range	Check the nominal range of the device If necessary, use a device with a higher measuring range	Bit 23-2 of byte 14...24

Only for signal converter with SIL-qualification

If measured values are outside of the specification and an "Out of Specification" message is triggered, this message results in:

- Status message "Failure"
- Fault signal via the current output

Maintenance required

Code Text message	Cause	Action or description	DevSpec State in CMD 48
M500 Error with the reset delivery status	Saved reset delivery status is incorrect	Send device for repair	Bit 0 of byte 14...24
M501 Error in the non active linearisation table	Index markers are not continuously rising, for example illogical value pairs	check the linearization table, Delete table/Create new	Bit 1 of byte 14...24
M502 Error in the event memory	Hardware error in EEPROM	Exchange the electronics Send device for repair	Bit 2 of byte 14...24
M504 Error on a device interface	Hardware defect	Check connections Exchange the electronics Send device for repair	Bit 3 of byte 14...24
M507 Error in the device settings	Error during setup Error when carrying out a reset	Repeat setup, Repeat reset	Bit 4 of byte 14...24

5.9.2 Check 4...20 mA signal

Connect a multimeter in the suitable measuring range according to the wiring plan.

Error code	Cause	Action or description
4...20 mA signal is missing	Faulty connection to power supply	Check connection and if necessary correct according to wiring plan
	No power supply	Check cable for breaks; repair if necessary
	Operating voltage too low or load-resistance too high	Check, adapt if necessary
Signal is >22 mA or <3.6 mA	Electronic module or sensor defective	Exchange the device or send device for repair
4...20 mA signal not stable	Variation in the measured value	Use the display and adjustment module or PACTware/DTM to set damping, depending on the device



DANGER!

In hazardous area applications, the regulations for the wiring of intrinsically safe circuits must be observed.

5.9.3 Error messages via the display and operating module

Error code	Cause	Action or description
E013	No measurement value available or pressure greater than nominal range	Exchange the device or send device for repair
E017	Adjustment span too small	Repeat with modified values
E036	No executable signal converter software	Carry out software update or send device for repair
E041	Hardware error	Exchange the device or send device for repair

Depending on the reason for the fault and the measures taken, the steps described previously may need to be carried out again.

6.1 Replacement

**DANGER!**

Observe the national regulations for electrical installations!

**DANGER!**

All work on the electrical connections may only be carried out with the power disconnected. Take note of the voltage data on the nameplate!

**DANGER!**

Check whether the ambient air around the signal converter is explosive. Opening the signal converter in an explosive atmosphere may result in ignition and explosion.

**WARNING!**

*Installation, assembly, start-up and maintenance may only be performed by personnel trained in **explosion protection**. Additional regional standards, safety directives and laws must be observed at all times.*

**WARNING!**

Observe without fail the local occupational health and safety regulations. Any work done on the electrical components of the measuring device may only be carried out by properly trained specialists.

**CAUTION!**

The product may cause the signal converter to become extremely hot. Possible risk of burning. For this reason, promptly shut off the process or isolate the signal converter sufficiently from the product prior to starting work and check that the converter has cooled down to room temperature.

6.1.1 Change electronic insert

In case of a defect, the electronic insert can be exchanged by the user against an identical type. If no electronic insert is available on site, it can be ordered from the respective local sales representative. To order a replacement, the serial number of the signal converter is required. This is located on the nameplate of the device or on the delivery note.

**WARNING!**

*Installation, assembly, start-up and maintenance may only be performed by personnel trained in **explosion protection**. Additional regional standards, safety directives and laws must be observed at all times.*

6.1.2 Replace the pressure caps

If required, the cap flanges can be exchanged by the user for an identical type. If spare parts such as gaskets, screws, nuts or cap flanges are not available, they can be ordered through your local representative.



- To remove the pressure caps, loosen the M8 hexagonal screws crosswise with an open-ended spanner SW13. Remove the pressure caps carefully to avoid damaging the separating diaphragms.
- Clean the O-ring groove in the pressure caps and, if necessary, the separating diaphragms with a suitable solvent and a soft cloth.
- Note the additional cleaning with oil and grease-free version.
- Insert the new O-rings into the groove of the pressure caps and ensure that the seals are seated correctly. Only use new and undamaged O-rings.
- Carefully fit the pressure caps to the differential pressure cell so that the seal remains in the groove during installation.
- Ensure the correct position and exact alignment of the two process flanges.
- A flat surface is suitable as an aid for aligning the process flanges.
- Use undamaged M8 screws for cap mounting and tighten them crosswise.

Proceed in 4 steps:

1. First tighten the screws with a tightening torque of 8 Nm.
2. Tighten the screws with a tightening torque of 12 Nm.
3. Tighten the screws with a tightening torque of 16 Nm.
4. Finally, tighten the screws with a tightening torque of 22 Nm.

After the installation in the measuring point, repeat the zero adjustment.

6.2 Software update

The device software can be updated in the following ways:

- USB Communicator

The following components are required:

Always needed

- Pressure transmitter
- Power supply
- Software update as a file

Wired instrument connection

- USB Communicator
- USB interface driver
- Computer with PACTware™/DTM



INFORMATION!

The latest version of the signal converter software and the USB interface driver can be found on the manufacturer website (Downloads). Further information is provided in the software update file.

Certain approvals can be subject to a specific software version. Therefore, when carrying out an update, ensure the approval is retained.

Only for signal converters with SIL-qualification

Ensure that you are using the correct software with SIL-qualification. Devices with SIL-qualification can only be updated with the appropriate software. It is impossible to accidentally update it with the wrong software version.

6.3 Maintenance

When used correctly, no maintenance is required in normal operation. In some applications, the measurement can be distorted by adhesive media. In this case, suitable measures should be taken to avoid adhesions and especially hardening on the diaphragm surface and in the pressure connection.

6.4 Spare parts availability

The manufacturer adheres to the basic principle that functionally adequate spare parts for each device or each important accessory part will be kept available for a period of 3 years after delivery of the last production run for the device.

This regulation only applies to spare parts which are subject to wear and tear under normal operating conditions.

6.5 Availability of services

The manufacturer offers a range of services to support the customer after expiration of the warranty. These include repair, maintenance, technical support and training.



INFORMATION!

For more precise information, please contact your local sales office.

6.6 Repairs

Repairs must be carried out exclusively by the manufacturer or the manufacturer authorised specialist companies.

6.7 Returning the device to the manufacturer

6.7.1 General information

This device has been carefully manufactured and tested. If installed and operated in accordance with these operating instructions, it will rarely present any problems.



WARNING!

Should you nevertheless need to return a device for inspection or repair, please pay strict attention to the following points:

- *Due to statutory regulations on environmental protection and safeguarding the health and safety of the personnel, the manufacturer may only handle, test and repair returned devices that have been in contact with products without risk to personnel and environment.*
- *This means that the manufacturer can only service this device if it is accompanied by the following certificate (see next section) confirming that the device is safe to handle.*

**WARNING!**

If the device has been operated with toxic, caustic, radioactive, flammable or water-endangering products, you are kindly requested:

- *to check and ensure, if necessary by rinsing or neutralising, that all cavities are free from such dangerous substances,*
- *to enclose a certificate with the device confirming that it is safe to handle and stating the product used.*

6.7.2 Form (for copying) to accompany a returned device



CAUTION!

To avoid any risk for our service personnel, this form has to be accessible from outside of the packaging with the returned device.

Company:		Address:	
Department:		Name:	
Telephone number:		Email address:	
Fax number:			
Manufacturer order number or serial number:			
The device has been operated with the following medium:			
This medium is:	<input type="checkbox"/>	radioactive	
	<input type="checkbox"/>	water-hazardous	
	<input type="checkbox"/>	toxic	
	<input type="checkbox"/>	caustic	
	<input type="checkbox"/>	flammable	
	<input type="checkbox"/>	We checked that all cavities in the device are free from such substances.	
	<input type="checkbox"/>	We have flushed out and neutralized all cavities in the device.	
We hereby confirm that there is no risk to persons or the environment caused by any residual media contained in this device when it is returned.			
Date:		Signature:	
Stamp:			

6.8 Disposal



LEGAL NOTICE!

Disposal must be carried out in accordance with legislation applicable in your country.

Separate collection of WEEE (Waste Electrical and Electronic Equipment):



According to the directive 2012/19/EU or UK Regulation 2013 No. 3113, the monitoring and control instruments marked with the WEEE symbol and reaching their end-of-life **must not be disposed of with other waste.**

The user must dispose of the WEEE to a designated collection point for the recycling of WEEE or send them back to our local organisation or authorised representative.

6.9 Digital sensor trim

The digital sensor trim is used to readjust pressure deviations and the measuring range according to a pressure reference. The zero trim corrects the pressure deviation of the transmitter at the beginning of the measuring range (LRV), while the span trim corrects the measuring deviation at the end of the measuring range (URV). In order to perform a digital trim, an accurate pressure reference is required.

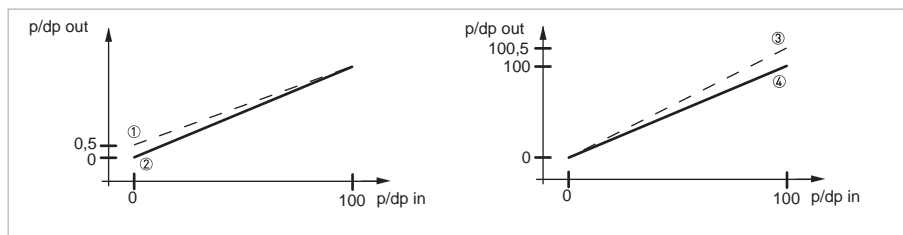

Figure 6-1: Digital sensor trim

- ① Characteristic curve before zero point trim
- ② Characteristic curve after zero point trim
- ③ Characteristic curve before span trim
- ④ Characteristic curve after span trim

6.9.1 Digital sensor trim via the display and adjustment module

Before the digital sensor trim can be performed, any active offset correction needs to be reset. Therefore, the value of the sensor mounting correction needs to be set to 0 manually via **Extended adjustment -> Setup -> Sensor mounting correction -> Edit**. After the digital sensor trim has been performed, the effect of mounting position can be corrected again via the automatic sensor mounting correction.

To perform the digital sensor trim via the display and adjustment module, navigate through the menu as follows **Extended adjustment -> Additional settings -> Special parameters -> SP02 / SP03 / SP04**

The password for access to the special parameters is: SW

Performing the zero point trim (SP02)

To carry out the zero point trim, special parameter SP02 needs to be selected and confirmed. It needs to be ensured that the system is completely depressurized. The currently applied pressure is set as the new zero point (LRV) and assigned to the current output value of 4 mA. The characteristic curve is adjusted on one side during this procedure, so that the end of the measuring range (URV) remains unaffected.

Performing the span trim (SP03)

To perform the span trim, special parameter SP03 needs to be selected and confirmed. It needs to be ensured that the applied pressure reference corresponds to the desired end of the measuring range (URV). The currently applied pressure is set as new span (URV) and assigned to the current output value of 20 mA. The characteristic curve is adjusted on one side during this procedure, so that the lower range value (LRV) remains unaffected.

Reset of the digital sensor trim (SP04)

Special parameter SP04 resets the zero point and span trim back to factory settings. Attention: If a reset to factory settings is carried out, the previously set trim values are retained! A reset to the basic settings, resets the trim values to the original factory settings.

6.9.2 Digital sensor trim via the KROHNE DTM

The digital sensor trim can be carried out via PACTware_{TM} and the Device Type Manager (DTM). Therefore, the sensor needs to be connected to the terminal instrument via a suitable interface. To get to the appropriate menu items, the following steps need to be carried out: **Menu -> Parameter -> Parameterisation**.

Before the digital sensor trim can be performed, an active offset correction needs to be reset. Therefore, the value of the sensor mounting corrections needs to be set to 0 manually via: **Setup -> Sensor mounting correction**. Via the **Apply** button the change can be uploaded to the device. After the digital sensor trim has been performed, the effect of mounting position can be corrected again via the automatic sensor mounting correction.

To get access to the special parameters, the service login needs to be activated. Therefore, select the wrench button above the menu and enter the password kps1921 via **Service Login**. The special parameters can be accessed via: **Additional settings -> Special parameters** in the menu.

Performing the zero point trim

To carry out the zero point trim, select **Sensor calibration -> Activate LRV** in the drop down menu of the section (2-4) and confirm the selection with **Execute action**. It needs to be ensured that the system is completely depressurised. The currently applied pressure is set as the new zero point (LRV) and assigned to the current output value of 4 mA. The characteristic curve is adjusted on one side during this procedure, so that the end of the measuring range (URV) remains unaffected. To finally complete the configuration, the parameterisation needs to be written into the instrument using the **Apply** button.

Performing the span trim

To carry out the span trim, select **Sensor calibration -> Activate LRV** in the drop down menu of the section (2-4) and confirm the selection with **Execute action**. It needs to be ensured that the applied pressure reference corresponds to the desired end of the measuring range (URV). The currently applied pressure is set as the new measuring span (URV) and assigned to the current output value of 20 mA. The characteristic curve is adjusted on one side during this procedure so that the lower range value (LRV) remains unaffected. To finally complete the configuration, the parameterisation needs to be written into the instrument using the **Apply** button.

Reset of the digital sensor trim

To reset the zero point and span trim, select **Sensor calibration -> Reset Calibration** in the drop down menu of the section (2-4) and confirm the selection with **Execute action**. To finally complete the configuration, the parameterisation needs to be written to the instrument using the **Apply** button.

7.1 Measuring principle

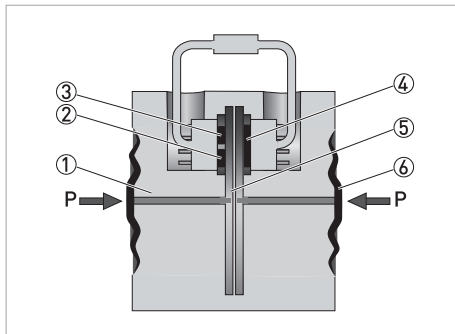

- ① Fill fluid
- ② Temperature sensor
- ③ Absolute pressure sensor
- ④ Differential pressure sensor
- ⑤ Overload system
- ⑥ Separating diaphragm

The process pressure is transferred via the separating metallic diaphragms ⑥ of the high and low pressure side and the fill fluid ① to the piezoresistive silicon sensor. Through the prevailing pressure differential, the silicon diaphragm of the differential pressure sensor ④ is deflected and changes the resistance value of the four piezoresistive elements in the bridge circuit. The change in resistance of the bridge circuit is proportional to the differential pressure. Additionally, the measured cell temperature ② and the prevailing static pressure ③ on the low pressure side is measured and then made available to the signal converter for further processing. If the measurement limit is exceeded, the overload system ⑤ restricts the prevailing process pressure at the differential pressure sensor and protects it from damage.

7.2 Technical data



INFORMATION!

- The following data is provided for general applications. If you require data that is more relevant to your specific application, please contact us or your local sales office.
- Additional information (certificates, special tools, software,...) and complete product documentation can be downloaded free of charge from the website (Downloadcenter).

Measuring system

Measuring principle	Piezoresistive differential pressure cell
Application range	<ul style="list-style-type: none"> • Volumetric and mass flow measurement in gases, vapours and liquids • Differential pressure measurement • Level measurement • Density measurement • Interface measurement
Measuring range	10 mbar, 30 mbar, 100 mbar, 500 mbar, 3 bar, 16 bar / 0.145 psi, 0.435 psi, 1.45 psi, 7.25 psi, 43.5 psi, 232.1 psi
Display and User interface	
Local control	<ul style="list-style-type: none"> • Operation via 4 push buttons on the display and adjustment module
Display and adjustment module	<ul style="list-style-type: none"> • Indication of measured value or derived measured value such as filling height • Quick start adjustment and extended adjustment of all parameters • Warning and diagnostic information
Remote control	<ul style="list-style-type: none"> • Bluetooth® via OPTICHECK Pressure Mobile application available in Google Play Store and Apple App Store • PACTware™, incl. Device Type Manager (DTM) • HART® Hand Held Communicator • AMS® from Emerson Process • PDM® from Siemens
Operating and display languages	German, English, French, Spanish, Portuguese, Italian, Dutch, Russian, Turkish, Polish, Czech, Chinese and Japanese
Integrated clock	
Date format	Day / Month / Year
Time format	12 hours / 24 hours
Time zone	CET (Factory setting)
Rate deviation	Maximum 10.5 minutes / year

Measuring accuracy

Differential pressure				
Reference conditions acc. to IEC 60770-1	<ul style="list-style-type: none"> Ambient temperature (constant): +18...+30°C / +64...+86°F Relative humidity (constant): 45...75% Ambient pressure (constant): 860...1060 mbar / 86...106 kPa / 12.5...15.4 psi Vertical mounting position Curve characteristic: Linear Measurement start at 0.00 bar / kPa / psi Process diaphragm: 316L / 1.4435 Fill fluid: Silicone oil Material of process flanges: 316L / 1.4404 Power supply: 24 VDC ±3 VDC Load for HART[®]: 250 Ω Effect of mounting position ≤ 0.35 mbar per 10° inclination around the transverse axis (a position-dependent zero offset can be corrected) Deviation in the current output due to strong, high-frequency electromagnetic fields acc. to EN 61326-1 <± 150 μA 			
Reference accuracy acc. to DIN EN 61298	Includes the non-linearity, hysteresis and repeatability under reference conditions. Applies to the digital interfaces (HART [®] , Profibus PA, Foundation Fieldbus) as well as for the analogue 4...20 mA current output. Turn down (TD) is the relation of nominal range/set measuring span. [% of the set span]			
	TD < 5:1	TD > 5:1	TD < 10:1	TD > 10:1
10 mbar / 0.145 psi	<± 0.10	<± 0.02 x TD		
30 mbar / 0.435 psi				
100 mbar / 1.45 psi			<± 0.065	<±0.035 + 0.01 x TD
500 mbar / 7.25 psi				<±0.015 + 0.005 x TD
3 bar / 43.5 psi				
16 bar / 232.1 psi				<±0.035 + 0.01 x TD
Effect of ambient temperature	Ambient temperature effect on zero and span in relation to the set measuring span. Applies to the digital interfaces (HART [®] , Foundation Fieldbus, Profibus PA) as well as for the analogue 4...20 mA current output. [% of the set span per 28°C / 50°F] All performance characteristics are in conformance with ≥ ± 3-sigma			
	-10...+60°C / +14...+140°F	-40...-10°C / -40...+14°F	+60...+85°C / +140...+185°F	
10 mbar / 0.145 psi	0.25 x TD + 0.03 Max. 0.2 x TD + 0.15 ①	Max. 0.3 x TD + 0.4 ①		
30 mbar / 0.435 psi	0.08 x TD + 0.08 Max. 0.1 x TD + 0.15 ①	Max. 0.15 x TD + 0.2 ①		
100 mbar / 1.45 psi	0.03 x TD + 0.08 Max. 0.15 x TD + 0.15 ①	Max. 0.2 x TD + 0.15 ①		
500 mbar / 7.25 psi	0.01 x TD + 0.14 Max. 0.05 x TD + 0.15 ①	Max. 0.06 x TD + 0.2 ①		
3 bar / 43.5 psi	0.08 x TD + 0.07 Max. 0.05 x TD + 0.15 ①	Max. 0.06 x TD + 0.2 ①		
16 bar / 232.1 psi	0.03 x TD + 0.12 Max. 0.15 x TD + 0.15 ①	Max. 0.2 x TD + 0.15 ①		
① Maximum value applies for the entire temperature intervall				

Effect of system pressure	System pressure effect on zero and span in relation to the set measuring span. Zero-point offset can be adjusted under operating pressure. Applies to the digital interfaces (HART®, Profibus PA, Foundation Fieldbus) as well as for the analogue 4...20 mA current output. [% of the set span per 40bar / 580psi for measuring ranges 100mbar-16bar] [% of the set span per 1bar / 14.5psi for measuring ranges 10mbar and 30mbar] All performance characteristics are in conformance with $\geq \pm 3$ -sigma					
	Measuring range		on zero (max. 0.1) ①		on span (max. 0.1) ①	
	10 mbar / 0.145 psi		0.007 x TD		0.011	
	30 mbar / 0.435 psi		0.005 x TD		0.01	
	100 mbar / 1.45 psi		0.03 x TD		0.05	
	500 mbar / 7.25 psi		0.02 x TD		0.08	
	3 bar / 43.5 psi		0.03 x TD		0.08	
	16 bar / 232.1 psi		0.02 x TD		0.06	
① Maximum value applies for the entire system pressure intervall						
Long-term stability acc. to DIN 16086 and IEC 60770-1	Applies to the digital interfaces (HART®, Profibus PA, Foundation Fieldbus) as well as for the analogue 4...20 mA current output. [% of the set span]					
	<± 0.1 x TD over a period of 5 years					
Total performance in accordance with DIN 16086	Total performance at indicated nominal differential pressure, static pressure and temperature. [% of the set span]					
	Measuring range	up to TD	Nominal pressure	-10°C / +14°F	+60°C / +140°F	+30°C / +86°F
	10 mbar / 0.145 psi	1:1	20 bar / 290 psi	<± 0.38		<± 0.15
	30 mbar / 0.435 psi			<± 0.24		<± 0.144
	100 mbar / 1.45 psi	80 bar / 1160 psi	<± 0.184		<± 0.121	
	500 mbar / 7.25 psi		<± 0.218		<± 0.122	
	3 bar / 43.5 psi		<± 0.221		<± 0.122	
	16 bar / 232.1 psi		<± 0.221		<± 0.122	
The details of total performance comprise the reference accuracy, the effect of the ambient temperature on the zero point and the measuring span as well as the effect of the static pressure on the measuring span.						
$E_{perf} = \sqrt{((E_{\Delta TZ} + E_{\Delta TS})^2 + E_{\Delta PS}^2 + E_{lin}^2)}$ $E_{\Delta TZ} = \text{Effect of ambient temperature on the zero point}$ $E_{\Delta TS} = \text{Effect of ambient temperature on the measuring span}$ $E_{\Delta PS} = \text{Effect of the static pressure on the measuring span}$ $E_{lin} = \text{Reference accuracy}$						
Measuring cell temperature						
The evaluation is made by using the display and adjustment module for indication, the current output and additional current output for analogue signal output and HART®, Profibus PA and Foundation Fieldbus for digital signal output.						
Operating temperature / nominal temperature range:	-40...+105 °C / -40...+221°F					
Resolution	< 0.2 K					
Accuracy at -40...+105°C / -40...+221°F	<± 1 K					

Electronics temperature				
The evaluation is made by using the display and adjustment module for indication, the current output and additional current output for analogue signal output and HART®, Profibus PA and Foundation Fieldbus for digital signal output.				
Operating temperature / nominal temperature range	-40...+85°C / -40...+185°F			
Resolution	< 0.1 K			
Accuracy at -40...+85°C / -40...+185°F	<± 3 K			
System pressure				
Reference conditions acc. to IEC 60770-1	<ul style="list-style-type: none"> Ambient temperature (constant): +18...+30°C / +64...+86°F Relative humidity (constant): 45...75% Ambient pressure (constant): 860...1060 mbar / 86...106 kPa / 12.5...15.4 psi Vertical mounting position 			
Reference accuracy acc. to DIN EN 61298	Includes the non-linearity, hysteresis and repeatability under reference conditions. Applies to the digital interfaces (HART®, Profibus PA, Foundation Fieldbus) as well as for the analogue 4...20 mA current output. [% of URL]			
		up to nominal pressure acc. to URL absolute pressure	TD 1:1	
	10 mbar / 0.145 psi	40 bar / 580 psi	<± 0.10	
	30 mbar / 0.435 psi			
	100 mbar / 1.45 psi	160 bar / 2320 psi or 400 bar / 5800 psi		
	500 mbar / 7.25 psi			
	3 bar / 43.5 psi			
16 bar / 232.1 psi				
Effect of ambient temperature	Ambient temperature effect on zero and span. Applies to the digital interfaces (HART®, Foundation Fieldbus, Profibus PA) as well as for the analogue 4...20 mA current output. [% of URL]			
		up to nominal pressure acc. to URL absolute pressure	-10...+60°C / +14...140°F	-40...+80°C / -40...+176°F
	10 mbar / 0.145 psi	40 bar / 580 psi	<± 0.5	<± 0.5
	30 mbar / 0.435 psi			
	100 mbar / 1.45 psi	160 bar / 2320 psi or 400 bar / 5800 psi		
	500 mbar / 7.25 psi			
	3 bar / 43.5 psi			
16 bar / 232.1 psi				
Long-term stability acc. to DIN 16086 and IEC 60770-1	Applies to the digital interfaces (HART®, Profibus PA, Foundation Fieldbus) as well as for the analogue 4...20 mA current output. [% of URL]			
	<± 0.1 over a period of 5 years			

Operating conditions

Temperature		
Process temperature	Measuring cell seal	Standard version
	PTFE	-40...+105°C / -40...+221°F
	EPDM	-40...+105°C / -40...+221°F
	Copper	-40...+105°C / -40...+221°F
	FKM	-20...+105°C / -4...+221°F
Ambient temperature	-40...+80°C / -40...+176°F	
Storage temperature	-40...+80°C / -40...+176°F	
Climate category	4K 4H (air temperature: -20...+55°C / -4...131°F, humidity: 4...100% according to DIN EN 60721-3-4)	

Further operating conditions

Housing material	Version	Protection acc. to IEC 60529	Protection acc. to NEMA
Plastic (PBT)	Single chamber	IP66 / IP67	Type 4X
	Double chamber		
Aluminium	Single chamber	IP66 / IP67	Type 4X
	Double chamber		
Stainless steel (electro-polished)	Single chamber	IP66 / IP67	Type 4X
		IP69K	
Stainless steel (precision casting)	Single chamber	IP66 / IP67	Type 4X
	Double chamber		
Connection of the feeding power supply unit	Networks of overvoltage category III		
Altitude above sea level			
by default	up to 2000 m (6562 ft)		
with connected overvoltage protection	up to 5000 m (16404 ft)		
Pollution degree	2 (when used with fulfilled housing protection)		
Protection rating (IEC/EN 61010-1)	II		
Mechanical stress (depending on the instrument version)			
Reference conditions	<ul style="list-style-type: none"> Without mounting bracket Process flanges 316L / 1.4404 PN 160 Single chamber housing, aluminium 		
Vibration resistance acc. to IEC 60770-1	10...58 Hz, 0.35 mm 58...1000 Hz, 20 m/s ² 1 octave per minute, 10 cycles per axis		
Shock resistant according to IEC 60770-1	500 m/s ² , 6 ms 100 shocks per axis		
Noise according to IEC 60770-1	10...200 Hz, 1 (m/s ²) ² /Hz 200...500 Hz, 0.3 (m/s ²) ² /Hz 4 hours per axis		

Materials

Wetted parts	
Measuring cell seal	EPDM, PTFE (up to PN160), Copper, FKM
Fill fluid	Silicone oil, halocarbon oil
Process connection, screwed flange	316L / 1.4404, NACE MR0175 / MR0103, Hastelloy® C-276, Superduplex
Separating diaphragm	316L / 1.4435, NACE MR0175 / MR0103, Hastelloy® C-276, 316L (1.4435) + 6µm gold
Vent and lock screws	316L / 1.4404, NACE MR0175 / MR0103, Hastelloy® C-276
Non-wetted parts	
Sensor housing	Plastic PBT (Polyester), Aluminium AlSi10Mg low copper content <0.4% (powder-coated, basis: Polyester), 316L
Cable gland	PA, stainless steel, brass
Cable gland: Seal, closure	NBR, PA
Seal, housing lid	Silicone SI 850 R, NBR silicone-free
Inspection window housing cover	Polycarbonate (UL-746-C listed), glass with Aluminium and stainless steel precision casting housing
Ground terminal	316L
Screws and bolts for side flanges	up to PN160: Hexagon screw DIN 931 M8 x 85 A2-70, hexagon nut DIN 934 M8 A2-70
	PN400: Hexagon screw DIN 931 M8 x 85 A2-70, hexagon nut DIN 934 M8 A2-70

Process connection

Process	1/4-18 NPT (Female), IEC 61518 A
Mounting	7/16 UNF, M10 (up to PN160)

Electrical connections

Mechanical - Standard				
Cable entry	M20 x 1.5, 1/2-14 NPT			
Cable gland	M20 x 1.5, 1/2-14 NPT			
Blind plug	M20 x 1.5, 1/2-14 NPT			
Closing cap	M20 x 1.5, 1/2-14 NPT			
Connector option	M12 x 1, Harting HAN 7D, 8D, 7/8" FF			
Material cable gland / Seal insert	Cable diameter			
	5...9 mm / 0.20...0.35"	6...12 mm / 0.24...0.47"	7...12 mm / 0.27...0.47"	10...14 mm / 0.39...0.55"
PA / NBR	X	X	-	X
Brass, nickel-plated / NBR	X	X	-	-
Stainless steel / NBR	-	-	X	-
Wire cross-section (spring-loaded terminals)				
Massive wire, stranded wire	0.2...2.5 mm ² (AWG 24...14)			
Stranded wire with end sleeve	0.2...1.5 mm ² (AWG 24...16)			

Mechanical - Display and adjustment module	
Display element	Display with backlight turnable in 90° steps
Measured value indication	5 digits (13x7 mm / 0.51x0.27")
Adjustment elements	4 keys [OK], [->], [+], [ESC]
Bluetooth interface (optional)	Bluetooth LE 4.1
	Max. participants 1
	Effective range typ. 25 m / 82 ft (depending on the local conditions)
	Bluetooth Switch [On], [Off]
Protection rating	Unassembled IP20
	Mounted in the housing without lid IP40
Materials	ABS Housing
	Polyester foil inspection window
Functional safety	SIL non-reactive
Ambient temperatures below -20°C / -4°F may affect the readability of the display	
Electrical	
Operating voltage	Non-Ex device: 11...35 VDC
	Ex ia device: 11...30 VDC
	Ex d device: 11...35 VDC
	Background lighting on display from 16 VDC
Reverse polarity protection	Integrated
Permissible residual ripple	Non-Ex devices, for U_n 12 VDC (11 < U_B < 14 VDC) $\leq 0.7 V_{eff}$ (16...400 Hz)
	Ex ia devices for U_n 24 VDC (18 < U_B < 35 VDC) $\leq 1.0 V_{eff}$ (16...400 Hz)
Load	$R_{L,max}=(U_B-11) / 22 \text{ mA}$
Potential connections and electrical separating measures in the instrument	Electronics: Not electrically isolated
	Conductive connection: Between ground terminal and metallic process connection
	Reference voltage: 500 V AC (galvanic separation between electronics and metal housing parts)
Overvoltage category	III
Protection class	II

Output signal

Output signal	4...20 mA / HART® version 7.3 3.8...20.5 mA (factory setting acc. to NAMUR recommendation)	
Signal resolution	0.3 μ A	
Error signal of current output (adjustable)	High alarm $\geq 21 \text{ mA}$ Low alarm $\leq 3.6 \text{ mA}$, last valid measurement Last valid measured value (not possible with SIL)	
Max. output current	21.5 mA	
Switch-on phase	Run-up time with operating voltage U_B :	$\geq 12 \text{ VDC} \leq 9 \text{ s}$
		$< 12 \text{ VDC} \leq 22 \text{ s}$
	Starting current:	$\leq 10 \text{ mA}$ for 5 ms after switching on, then $\leq 3.6 \text{ mA}$

Additional current output (optional)	
Output signal	4...20 mA (passive)
Range of the output signal	3.8...20.5 mA (default setting)
Signal resolution	0.3 μ A
Error signal of second current output (adjustable)	High alarm \geq 21 mA, Low alarm \leq 3.6 mA, Last valid measured value (not possible with SIL)
Max. output current	21.5 mA
Starting current	\leq 10 mA for 5 ms after switching on, \leq 3.6 mA
Load	Load resistor, see chapter "Voltage supply"

Approvals and certificates

CE	The device complies with the legal requirements of the EU directive. The manufacturer confirms compliance with these regulations by affixing the CE marking.
Electromagnetic compatibility (EMC)	EN 61326-1:2013 EN 61326-2-3:2013
NAMUR	NE 21 - Electromagnetic compatibility of equipment NE 43 - Signal level for the failure information of digital transmitters NE 53 - Compatibility of field devices and display/adjustment components NE 107 - Self-monitoring and diagnosis of field devices
Classification according to Pressure Equipment Directive (PED 2014/68/EU)	PN160 (2320 psi), PN400 (5800 psi) - For gases of fluid group 1 and liquids of fluid group 1, the requirements are fulfilled according to article 3, paragraph 3 (sound engineering practice).

7.3 Pressure ranges

Min. / Max. adjustment:

Percent value: -10...110%

Pressure value: -20...120%

Zero/Span adjustment

Zero: -95...+95%

Span: -120...+120%

Difference between zero and span: max. = 120% of the nominal range.

Maximum allowed turn down = unlimited (recommended 20:1)

Recommended maximum Turn Down (TD): 20:1 (no limit)

Nominal ranges and overload capacity

This information is provided as an overview and refers to the measuring cell. Limitations due to the material and design of the process connection are possible. The information given on the nameplate applies. Data on overload capability apply for reference temperature.

Nominal range	10 mbar	30 mbar	100 mbar	500 mbar	3 bar	16 bar
Limit URL (upper)	10 mbar	30 mbar	100 mbar	500 mbar	3 bar	16 bar
Limit LRL (lower)	-10 mbar	-30 mbar	-100 mbar	-500 mbar	-3 bar	-16 bar
Smallest adjustable measuring span	0.5 mbar	1 mbar	1 mbar	5 mbar	30 mbar	160 mbar
Turn down	20:1	30:1	100:1	100:1	100:1	100:1
MWP (maximum system pressure) ①	40 bar	40 bar	160 bar / 400 bar	160 bar / 400 bar	160 bar / 400 bar	160 bar / 400 bar
Minimum system pressure	1 mbar abs (under reference conditions)					

① MWP corresponds to the PS designation in the PED (maximum system pressure)

Nominal range	0.145 psi	0.435 psi	1.45 psi	7.25 psi	43.5 psi	232.1 psi
Limit URL (upper)	0.145 psi	0.435 psi	1.45 psi	7.25 psi	43.5 psi	232.1 psi
Limit LRL (lower)	-0.145 psi	-0.435 psi	-1.45 psi	-7.25 psi	-43.5 psi	-232.1 psi
Smallest adjustable measuring span	0.007 psi	0.015 psi	0.015 psi	0.073 psi	0.435 psi	2.321 psi
Turn down	20:1	30:1	100:1	100:1	100:1	100:1
MWP (maximum system pressure) ①	580 psi	580 psi	2320 psi / 5800 psi	2320 psi / 5800 psi	2320 psi / 5800 psi	2320 psi / 5800 psi
Minimum system pressure	0.015 psi abs (under reference conditions)					

① MWP corresponds to the PS designation in the PED (maximum system pressure)

7.4 Ambient temperature effect on current output

Applies to the analogue 4...20 mA current output and refers to the set span
< 0.05% / 10 K, max. < 0.15%, each case at -40...+80°C / -40...+176°F

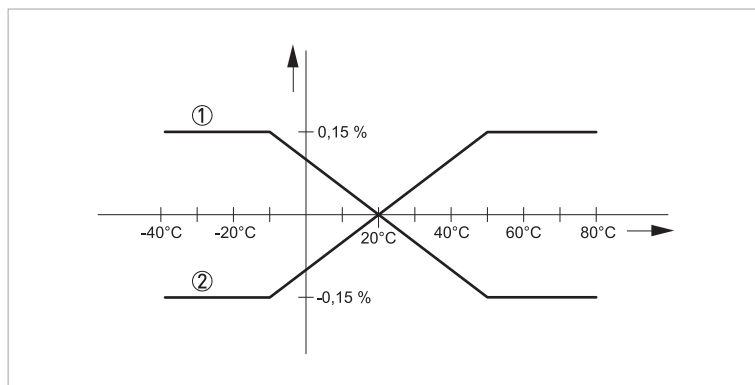

Figure 7-1: Ambient temperature effect on current output

- ① Falling characteristics
- ② Rising characteristics

7.5 Dynamic behaviour of the current output

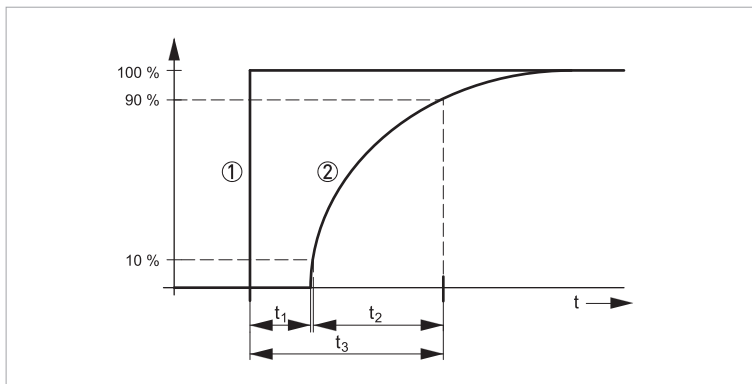

Figure 7-2: Behaviour at an abrupt change in the process variable.
 t_1 - dead time; t_2 - rise time; t_3 - step response time

- ① Process variable
- ② Output signal

	Dead time (t_1) [ms]	Rise time 10...90% (t_2) [ms]	Step response time (t_3) [ms]
10 mbar / 0.145 psi	145	745	890
30 mbar / 0.435 psi	145	115	260
100 mbar / 1.45 psi	125	95	220
500 mbar / 7.25 psi	125	75	200
3 bar / 43.5 psi	115	60	175
16 bar / 232.1 psi	115	60	175

Damping (63% of input variable) 0...999 seconds, adjustable in 0.1 second steps

These parameters depend on the fill fluid, temperature and, if applicable, the diaphragm seal system.

7.6 Dimensions and weight



INFORMATION!

The following dimensional drawings represent only an extract of the possible versions. Detailed dimensional drawings can be requested individually.

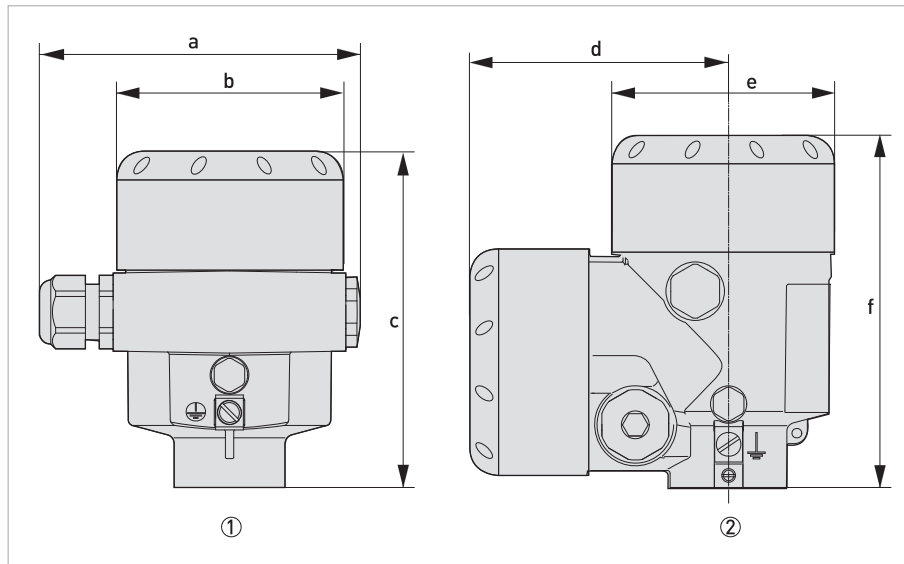

Figure 7-3: Aluminium housing

- ① Single chamber
- ② Double chamber

	Dimension [mm]	Dimension [inch]
a	116	4.57
b	86	3.39
c	116	4.57
d	87	3.43
e	86	3.39
f	120	4.72



INFORMATION!

With integrated display and adjustment module the height of the housing increases by 18 mm / 0.71 inch.

Housing version	Weight [kg]	Weight [lb]
Single chamber, aluminium	0.83	1.84
Double chamber, aluminium	1.24	2.73

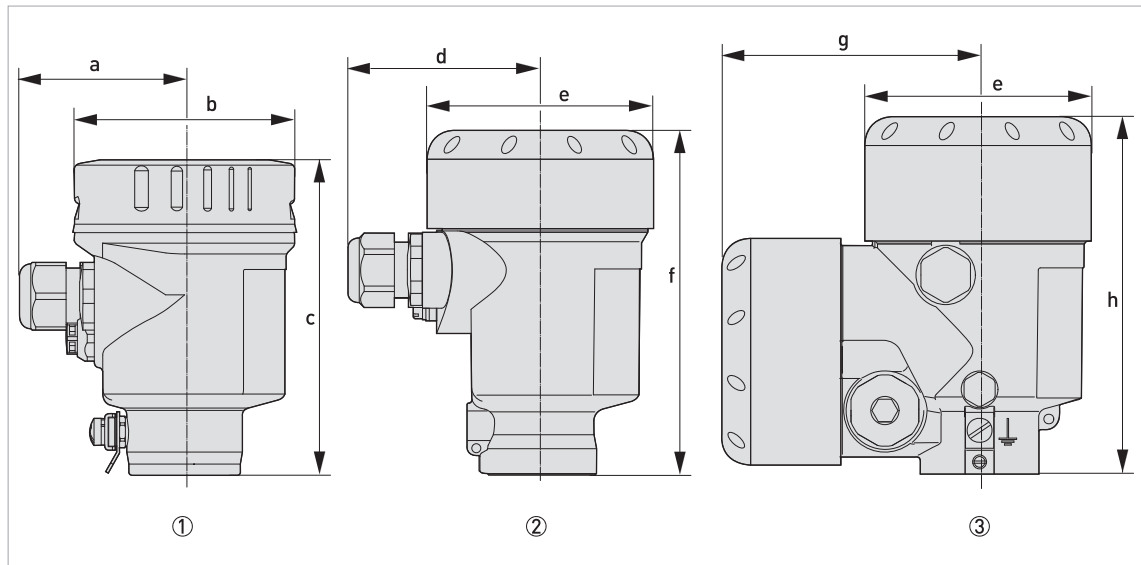

Figure 7-4: Stainless steel housing

- ① Single chamber, stainless steel (electro-polished)
- ② Single chamber, precision casting
- ③ Double chamber, precision casting

	Dimension [mm]	Dimension [inch]
a	59	2.32
b	80	3.15
c	112	4.41
d	69	2.72
e	79	3.11
f	117	4.61
g	87	3.42
h	120	4.72



INFORMATION!

With integrated display and adjustment module the height of the housing increases by 9 mm / 0.35 inch or 18 mm / 0.71 inch.

Housing version	Weight [kg]	Weight [lb]
Single chamber, stainless steel (electro-polished)	0.73	1.61
Single chamber, precision casting	1.31	2.89
Double chamber, precision casting	2.86	6.31

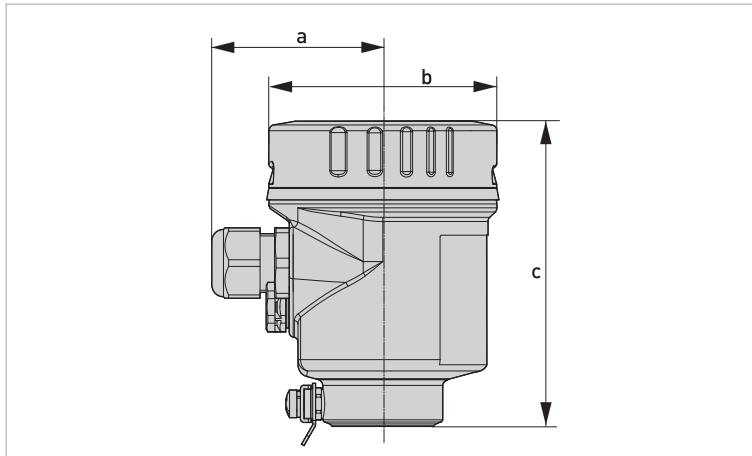

Figure 7-5: Stainless steel (electro-polished) IP69K version

	Dimension [mm]	Dimension [inch]
a	59	2.32
b	80	3.15
c	104	4.10



INFORMATION!

With integrated display and adjustment module the height of the housing increases by 9 mm / 0.35 inch.

Housing version	Weight [kg]	Weight [lb]
Single chamber, stainless steel (electro-polished)	0.73	1.61

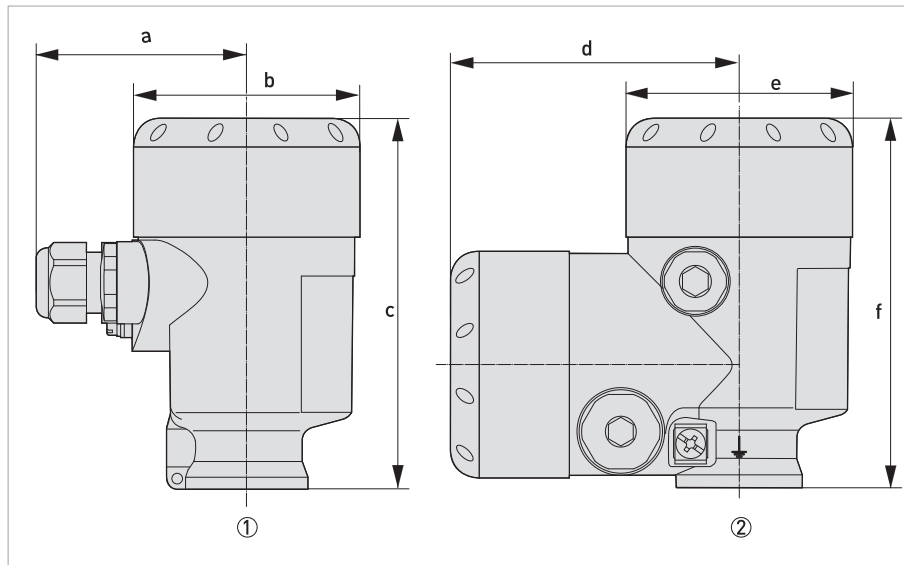

Figure 7-6: Plastic housing

- ① Single chamber
- ② Double chamber

	Dimension [mm]	Dimension [inch]
a	69	2.72
b	79	3.11
c	112	4.41
d	84	3.31
e	79	3.11
f	112	4.41

**INFORMATION!**

With integrated display and adjustment module the height of the housing increases by 9 mm / 0.35 inch.

Housing version	Weight [kg]	Weight [lb]
Single chamber, plastic	0.40	0.88
Double chamber, plastic	0.51	1.13

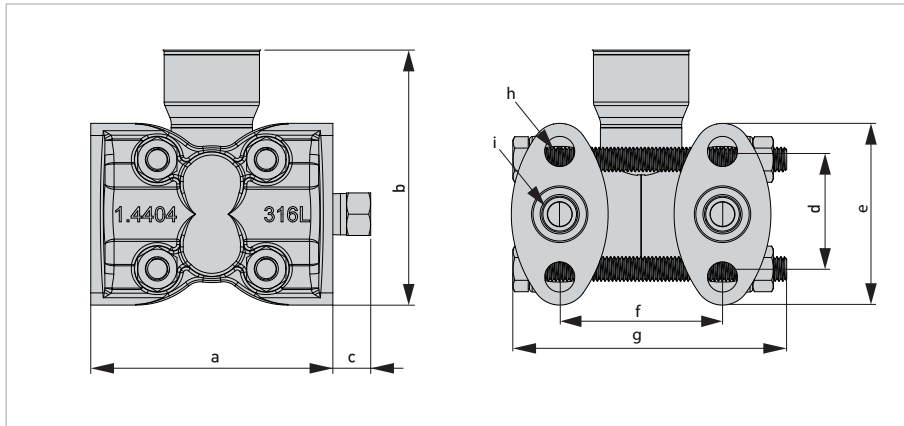

Figure 7-7: 1/4-18 NPT Process connection without venting (S0)

	Dimension [mm]	Dimension [inch]
a	80	3.15
b	84	3.3
c	13	0.51
d	41	1.61
e	60	2.36
f	54	2.13
g	91	3.58
h		7/16 UNF or M10
i		1/4-18 NPT



INFORMATION!

Overall height of the differential pressure transmitter = b (process connection) + overall height of the respective housing

	Weight [kg]	Weight [lb]
Process connection	1.48	3.26

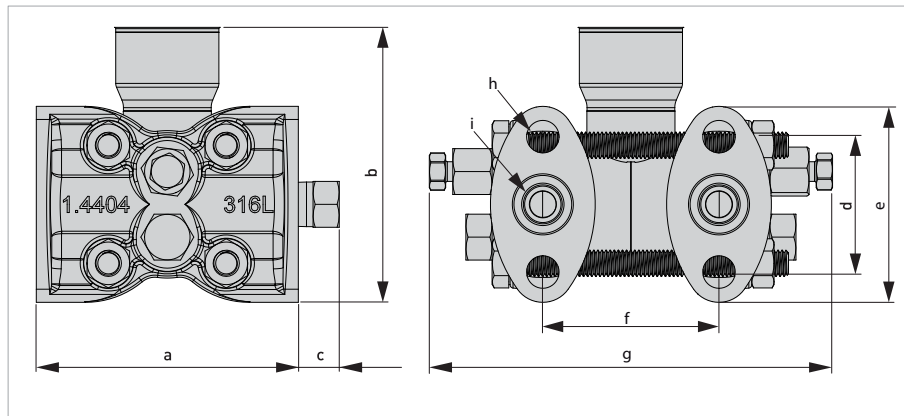

Figure 7-8: 1/2 NPT with side vent (SD)

	Dimension [mm]	Dimension [inch]
a	80	3.15
b	84	3.3
c	13	0.51
d	41	1.61
e	60	2.36
f	54	2.13
g	125	4.92
h		7/16 UNF
i	1/4-18 NPT according to IEC 61518 A	

**INFORMATION!**

Overall height of the differential pressure transmitter = b (process connection) + overall height of the respective housing

	Weight [kg]	Weight [lb]
Process connection, side vent	0.73	1.61

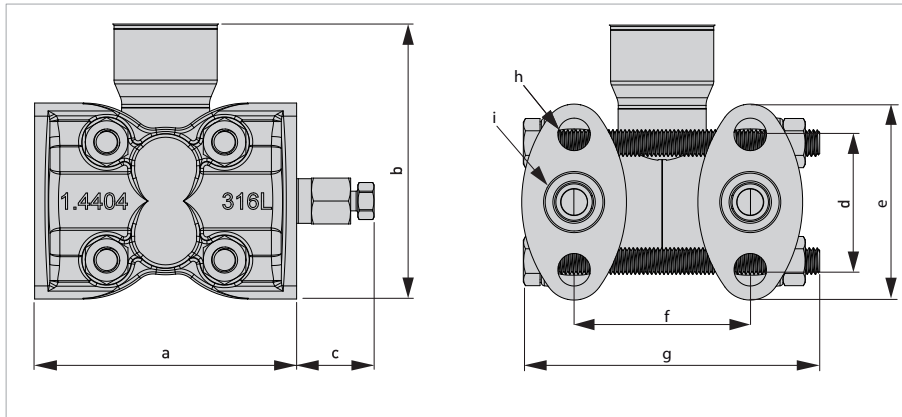

Figure 7-9: 1/4 NPT venting on the process axis (SR)

	Dimension [mm]	Dimension [inch]
a	80	3.15
b	84	3.3
c	13	0.51
d	41	1.61
e	60	2.36
f	54	2.13
g	125	4.92
h		7/16 UNF
i		1/4-18 NPT according to IEC 61518 A



INFORMATION!

Overall height of the differential pressure transmitter = b (process connection) + overall height of the respective housing.

	Weight [kg]	Weight [lb]
Process connection, side vent	1.5	3.31

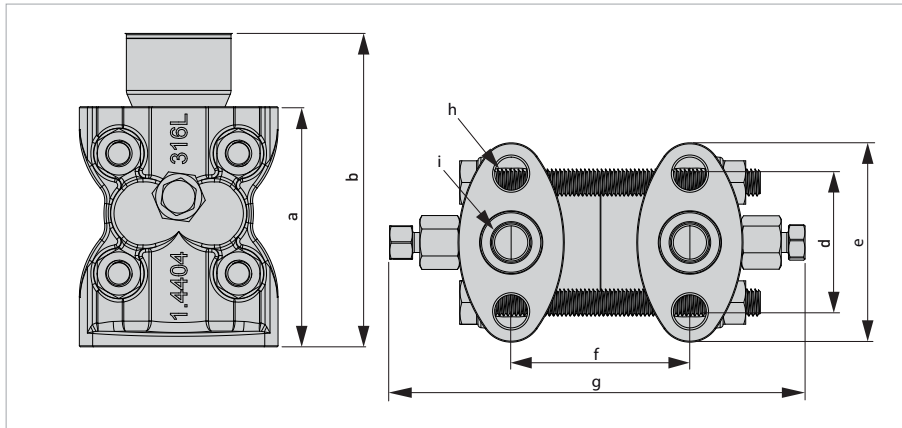

Figure 7-10: 90° vertical 1/4-18 Process connection, side vent (VD)

	Dimension [mm]	Dimension [inch]
a	72	2.83
b	94	3.7
d	41	1.61
e	60	2.36
f	54	2.13
g	125	4.92
h	7/16 UNF	
i	1/4-18 NPT according to IEC 61518 A	

**INFORMATION!**

Overall height of the differential pressure transmitter = b (process connection) + overall height of the respective housing.

	Weight [kg]	Weight [lb]
Process connection, side vent	0.63	1.39

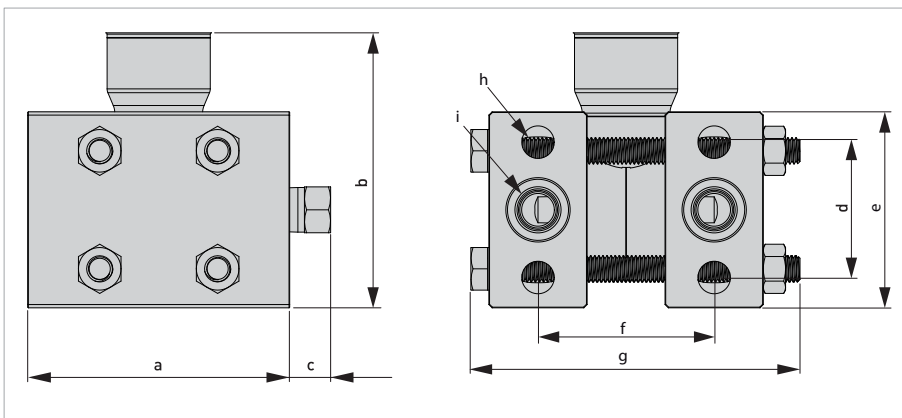

Figure 7-11: 1/4 NPT without venting, Process connection in Hastelloy® C-276 (H0)

	Dimension [mm]	Dimension [inch]
a	80	3.15
b	84	3.3
c	13	0.51
d	41	1.61
e	59	2.32
f	54	2.13
g	101	3.98
h		7/16 UNF
i		1/4-18 NPT according to IEC 61518 A



INFORMATION!

Overall height of the differential pressure transmitter = b (process connection) + overall height of the respective housing.

	Weight [kg]	Weight [lb]
Process connection in Hastelloy® C-276	2.29	5.05

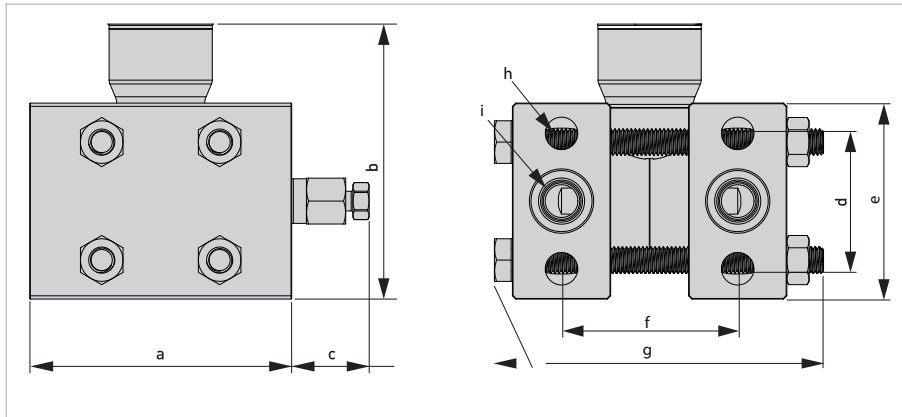

Figure 7-12: 1/4 NPT Process connection in Hastelloy C-276 with venting on the process axis (HR)

	Dimension [mm]	Dimension [inch]
a	80	3.15
b	84	3.3
c	25	0.98
d	41	1.61
e	60	2.36
f	54	2.13
g	101	3.98
h		7/16 UNF
i		1/4-18 NPT according to IEC 61518 A



INFORMATION!

Overall height of the differential pressure transmitter = b (process connection) + overall height of the respective housing.

	Weight [kg]	Weight [lb]
Process connection in Hastelloy, side vent	2.31	5.1

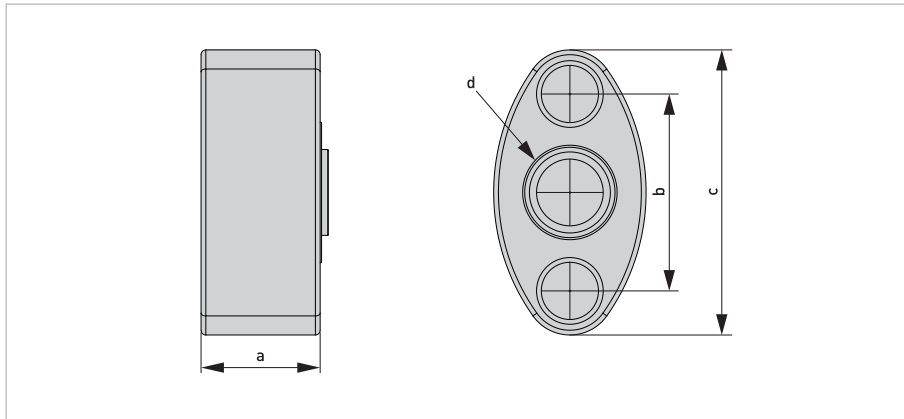

Figure 7-13: Oval flange adapter (Ax)

	Dimension [mm]	Dimension [inch]
a	25	0.98
b	41	1.61
c	60	2.36
d		1/2 NPT



INFORMATION!

Overall height of the differential pressure transmitter = b (process connection) + overall height of the respective housing.

	Weight [kg]	Weight [lb]
Mounting bracket	0.2	0.44

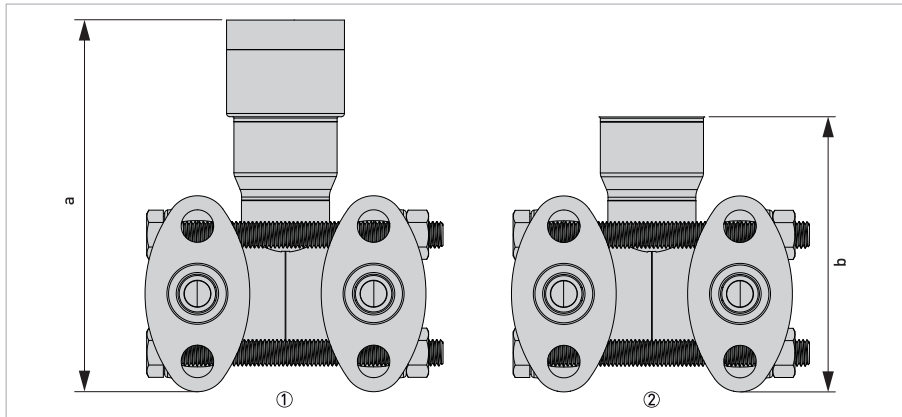

Figure 7-14: Adapter versions

- ① Adapter for versions with protection type "flameproof enclosure" Ex d
- ② Adapter for all versions with the exception of "flameproof enclosure" Ex d

	Dimension [mm]	Dimension [inch]
a	113	4.45
b	84	3.31

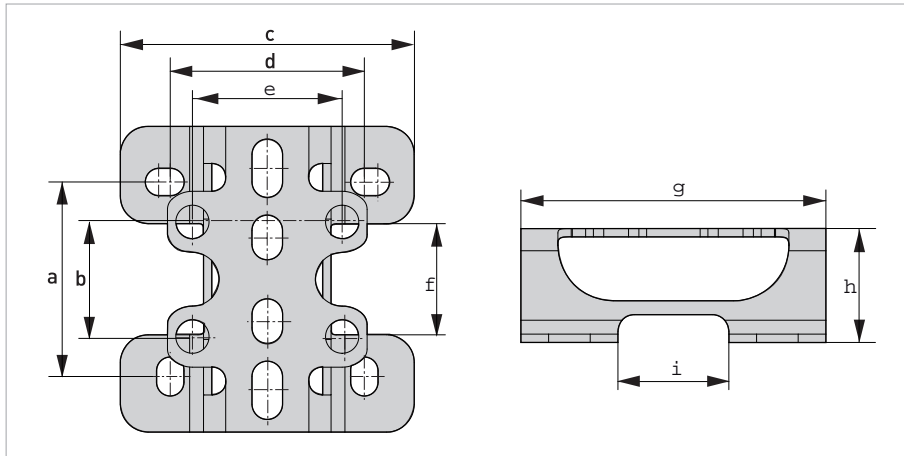

Figure 7-15: Mounting bracket (pipe and wall mounting 2" / 50.8 mm)

	Dimension [mm]	Dimension [inch]
a	70	2.76
b	41	1.61
c	106	4.17
d	70	2.76
e	54	2.13
f	40	1.57
g	110	4.33
h	41	1.61
i	40	1.57

	Weight [kg]	Weight [lb]
Mounting bracket	0.33	0.73

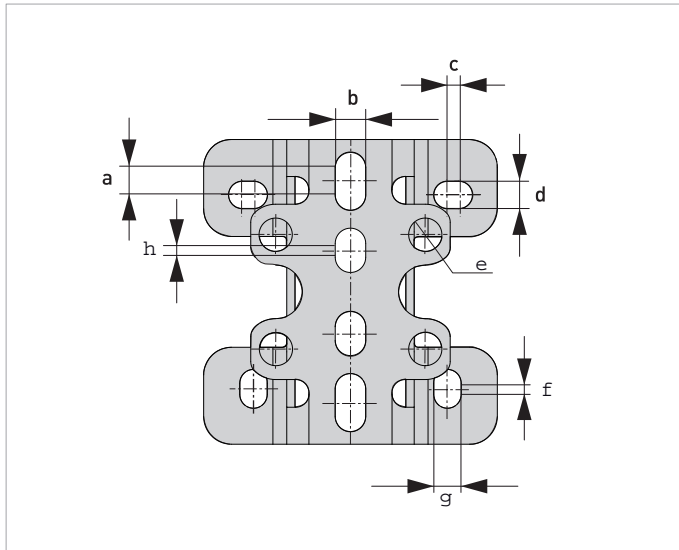

Figure 7-16: Mounting bracket (pipe and wall mounting 2" / 50.8 mm)

	Dimension [mm]	Dimension [inch]
a	10	0.39
b	11	0.43
c	4	0.16
d	10	0.39
e	4x Ø12	4x Ø0.47
f	4	0.16
g	10	0.39
h	5	0.2

8.1 General description

The open HART[®] protocol which can be used for free, is integrated into the signal converter for communication.

Devices which support the HART[®] protocol are classified as either operating devices or field devices. When it comes to operating devices (Master), both manual control units (Secondary Master) and PC-supported workstations (Primary Master) are used in, for example, a control centre.

HART[®] field devices include measuring sensors, signal converters and actuators. The field devices range from 2-wire to intrinsically safe versions for use in hazardous areas.

The HART[®] data are superimposed over the analogue 4...20 mA signal via FSK modem. This way, all of the connected devices can communicate digitally with one another via the HART[®] protocol while simultaneously transmitting the analogue signals.

When it comes to the field devices and secondary masters, the FSK or HART[®] modem is integrated. If a PC is used, an external modem must be connected to the serial interface (USB interface). There are, however, other connection variants which can be seen in the following connection figures.

The serial number of each device is indicated on the nameplate. For all communication interfaces such as DTMs, DDs, etc. the serial number is indicated in its short format.

8.2 Software history



INFORMATION!

In the table below, "x" is a placeholder for possible multi-digit alphanumeric combinations, depending on the available version.

Release date	SW version	HW version	HART [®]	
			Device Revision	DD Revision
2013-04-01	1.0.x	1.0.x	1	1
2016-07-01	1.2.x	1.0.x	2	2
2019-03-01	1.3.x	1.0.x	3	3

HART[®] identification codes and revision numbers

Manufacturer ID:	69 (0x45)
Device ID (non-SIL):	197 (0xC5)
Device ID (SIL 2/3):	189 (0xBD)
HART [®] Universal Revision:	7
FC 475 system SW.Rev.:	≥ 3.7
PDM version:	≥ 8.0
FDT version:	≥ 1.2

8.3 Connection variants

The signal converter is a 2-wire device with a passive 4...20 mA current output and a HART[®] interface.

- **Point-to-Point is supported**
In conventional point-to-point operation, the signal converter communicates as a slave with the master.
- **Multidrop mode is supported**
In a multidrop communication system, more than 2 devices are connected to a common transmission cable.
- **Burst Mode is not supported**
In the burst operation a slave device transfers cyclic pre-defined response telegrams, to get a higher rate of data transfer.

There are two ways of using the HART[®] communication:

- as Point-to-Point connection and
- as multidrop connection, with 2-wire connection.

8.3.1 Point-to-Point connection - analogue / digital mode

Point-to-Point connection between the signal converter and the HART[®] Master.

The current output of the device is passive.

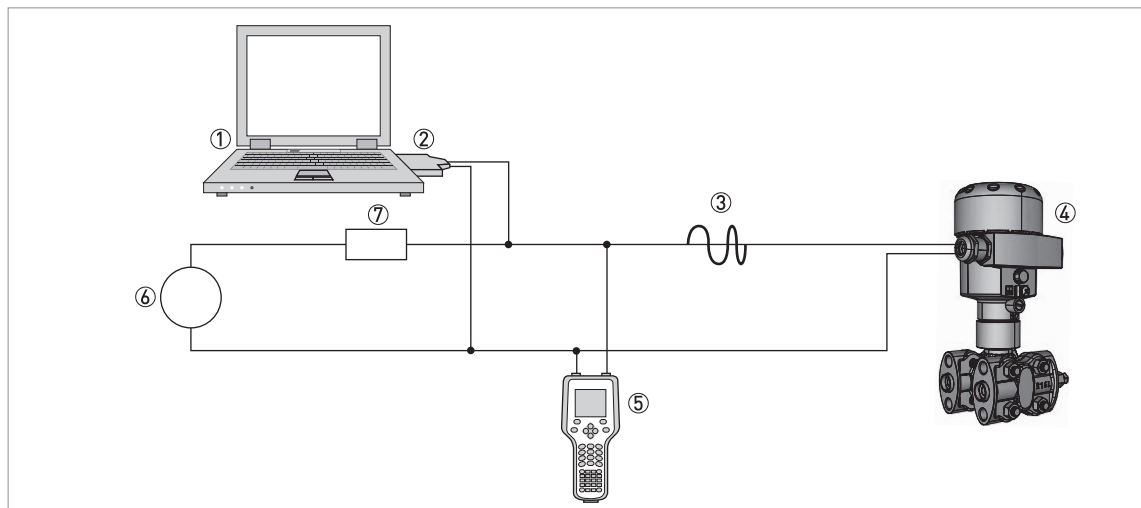

Figure 8-1: Point-to-Point connection

- ① Primary master with e.g. PACTware[™] FDT/DTM
- ② FSK modem
- ③ HART[®] signal
- ④ OPTIBAR DP 7060 C
- ⑤ Secondary master with HART[®] DD
- ⑥ Power supply for devices (slaves) with passive current output
- ⑦ Load $\geq 250 \Omega$

8.4 Inputs / Outputs and HART[®] dynamic variables and device variables

PV = Primary Variable; SV = Secondary Variable; TV = Third Variable; QV = Quarternary Variable



INFORMATION!

The output values can be assigned individually.

HART [®] dynamic variable			
PV	SV	TV	QV
Linear percent value	Static pressure	Differential pressure	Measuring cell temperature

Table 8-1: HART[®] output values acc. to HART[®] 7 (factory setting)

8.5 Field Communicator 475 (FC 475)

The Field Communicator is a hand terminal from Emerson Process Management that is designed to configure HART[®] and Foundation Fieldbus devices. Device Descriptions (DDs) are used to integrate different devices into the Field Communicator.

8.5.1 Installation

The HART[®] Device Description for the signal converter must be installed on the Field Communicator. Otherwise only the functions of a generic DD are available to the user and the entire device control is not possible. A "Field Communicator Easy Upgrade Programming Utility" is required to install the DDs on the Field Communicator.

The Field Communicator must be equipped with a system card with "Easy Upgrade Option". For details consult the Field Communicator User's Manual.

8.5.2 Operation

Operating the signal converter via the Field Communicator is very similar to manual device control using the keyboard.

8.6 Field Device Tool / Device Type Manager (FDT / DTM)

A Field Device Tool Container (FDT Container) is basically a PC program used to configure a field device via HART[®]. To adapt to different devices, the FDT container uses a so-called Device Type Manager (DTM).

8.6.1 Installation

If the DTM for the signal converter has not yet been installed on the FDT Container, setup is required and is available for download from the website or on CD-ROM. See the supplied documentation for information on how to install and set up the DTM.

KROHNE – Products, Solutions and Services

- Process instrumentation for flow, level, temperature, pressure measurement and process analytics
- Flow metering, monitoring, wireless and remote metering solutions
- Engineering, commissioning, calibration, maintenance and training services

Head Office KROHNE Messtechnik GmbH
Ludwig-Krohne-Str. 5
47058 Duisburg (Germany)
Tel.: +49 203 301 0
Fax: +49 203 301 10389
info@krohne.de

The current list of all KROHNE contacts and addresses can be found at:
www.krohne.com

